

PRODUCT GUIDE

timloc
building products



ROOFLINE

LOFT DOORS

TILE VENTS



INVISIWEEP



WALL WEEPS



AMBI-SOAKER



CAVITY TRAYS

INSULATION RETAINING DISCS



INTERNAL GRILLES

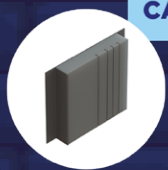
AIRBRICKS



TELESCOPIC UNDERFLOOR VENTS



CAVITY CLOSERS



RADON SUMP



Sustainable building products
from ground level up to the roof ridge

CONSTRUCTION
ACCESSORIES

CAVITY
TRAYS

CAVITY
CLOSERS

ACCESS
PRODUCTS

ADAPT-AIR

RAD-SEAL

ROOFLINE

THROUGH-WALL
VENTILATION

TOP HATS, GAS
BARRIERS & DPC

METER
BOXES

NEXT DAY

DELIVERY

ON ALL ORDERS PLACED BEFORE 12PM*

*All orders placed before 12pm Monday - Friday will be delivered the next working day. Applicable to standard stock items only, please see individual product pages for more information.

LOW CARRIAGE PAID ORDER VALUES



£100
TO BRANCH

£150
TO SITE



We are a **British manufacturer** supplying the building industry for over 50 years

At Timloc Building Products we manufacture and supply sustainable building products from ground level right up to the roof ridge, from our state-of-the-art manufacturing facility in East Yorkshire.

We are committed to sustainable manufacturing and over 75% of products are made from recycled plastics. Our products are designed for use throughout the lifespan of a building and are recyclable at the end of the building life.

GET SOCIAL



@timlocbp



@timlocbp



/timlocbp



@timlocbp



@timlocbp

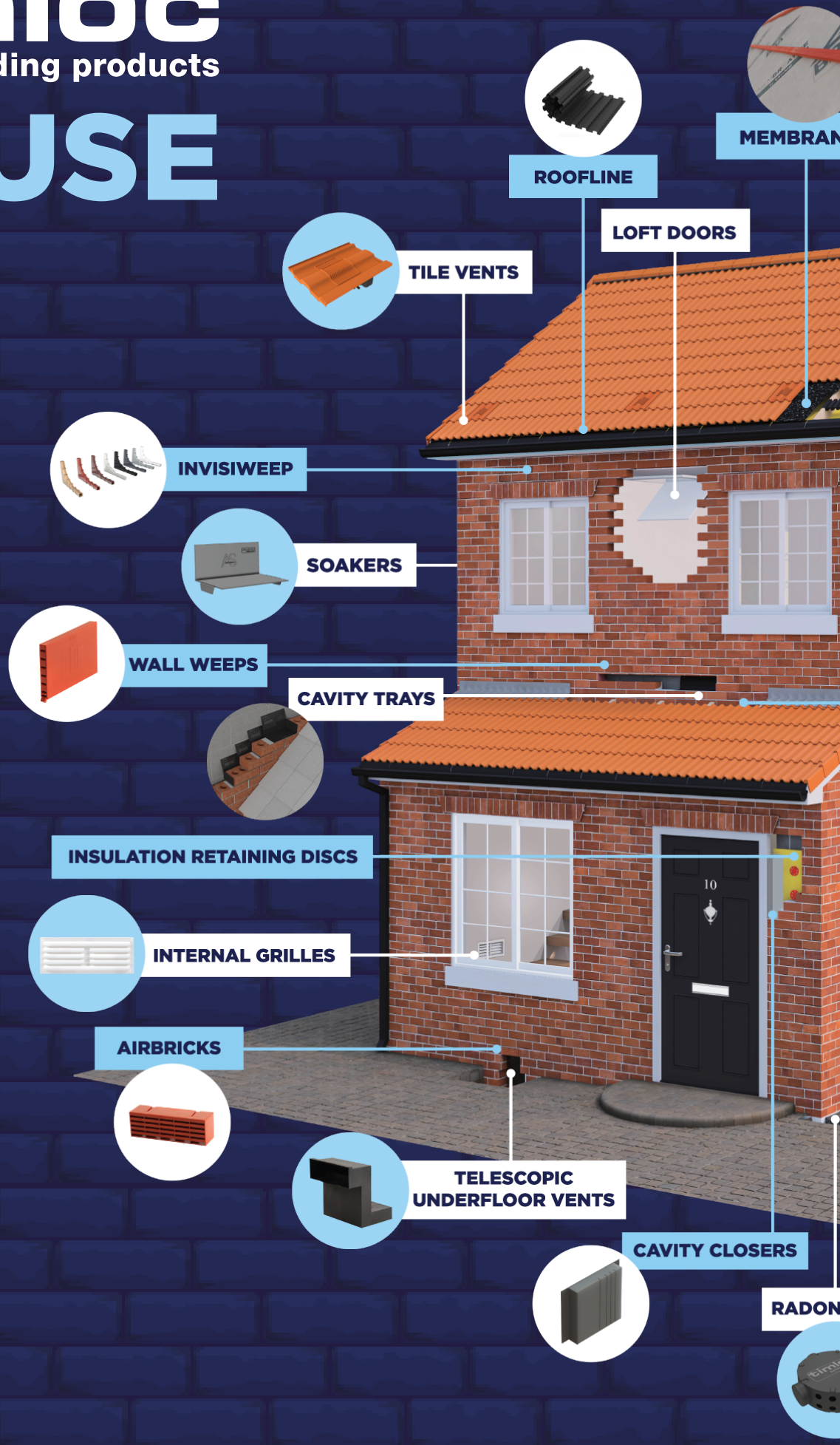


Timloc Building Products



- CONSTRUCTION ACCESSORIES
- CAVITY TRAYS
- CAVITY CLOSERS
- ACCESS PRODUCTS
- ADAPT-AIR
- RAD-SEAL
- ROOFLINE
- THROUGH-WALL VENTILATION
- TOP HATS, GAS BARRIERS & DPC
- METER BOXES

the timloc building products HOUSE



MEMBRAN

ROOFLINE

LOFT DOORS

TILE VENTS

INVISIPEEP

SOAKERS

WALL WEEPS

CAVITY TRAYS

INSULATION RETAINING DISCS

INTERNAL GRILLES

AIRBRICKS

TELESCOPIC UNDERFLOOR VENTS

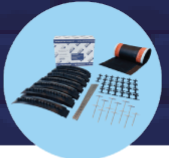
CAVITY CLOSERS

RADON



SCAN TO VIEW DIGITAL HOUSE

RANGE OF FIRE RATED & NON-COMBUSTIBLE PRODUCTS AVAILABLE



DRY RIDGE



DRY VERGE



ADAPT-AIR



ACCESS PANELS



CAVITY STOP SOCKS

EXTERNAL COWLS

METER BOXES



RAD-SEAL



HEDGEHOG HIGHWAY



TOP HATS

HOCKEY STICKS

SUMP



EVERYTHING UNDER ONE ROOF

8

CONSTRUCTION ACCESSORIES

Invisiweep	9
Invisiweep NC	10
Cavity Wall Weeps	11
Drill Vent by Timloc	12
Insulation Retaining Discs	13
1201 Airbrick	14
1201 Telescopic Underfloor Ventilator	15
1201XL Telescopic Underfloor Ventilator	16
1201XL+ Telescopic Underfloor Ventilator	17
Telescopic Underfloor Ventilator Accessories	18

47

CAVITY CLOSERS & STOP SOCKS

Cavity Closers & Stop Socks Table	48
Thermo-loc Platinum Multi Cavity Closer	49
Thermo-loc Platinum + Cavity Closer	50
Thermo-loc Platinum + FX Cavity Closer	52
Thermo-loc FR30 Cavity Closer	54
Thermo-loc FR60 Cavity Closer	56
Thermo-loc FR60+ Cavity Closer	58
FRstop Fire Rated Cavity Stop Sock for Masonry	60

74

ADAPT-AIR

Adapt-Air	75
Adapt-Air Test Data	77

20

CAVITY TRAYS

Everdry Adjustable Stepped Cavity Trays for Brickwork	22
Everdry Stepped Cavity Trays for Stonework	24
Everdry Stepped Cavity Trays for Blockwork	26
Everdry Stepped Cavity Trays for Brickwork - Lead Attached	28
Everdry Stepped Cavity Trays for Stonework - Lead Attached	30
Everdry Stepped Cavity Trays for Blockwork - Lead Attached	32
Inter-loc Horizontal Cavity Trays	34
System 2000 Horizontal Cavity Trays	36
System 2000E Horizontal Cavity Trays for Refurbishment	37
Inter-loc Horizontal Cavity Trays - Lead Attached	38
System 2000 Horizontal Cavity Trays - Lead Attached	39
Over Lintel, General Purpose & Parapet Cavity Trays	40
Purpose Made Cavity Trays	41
Cavity Trays for Door & Window Openings	42
Lintel Stopend	43
Technical Information & Installation Advice	44

61

ACCESS PRODUCTS

1168 Plastic Push-up Loft Door	62
1169 Plastic Hinged Drop Down Loft Door	63
Z-Series Metal 1 Hour Fire Rated Loft Door - Full Range	64
Z-Series Metal 1 Hour Fire Rated Loft Door - 1160/1161	66
Loft-loc Loft Door Operating Pole	68
Loft Doors - Technical Information & Installation Advice	69
Plastic Access Panels	70
Airtight Plastic Access Panels	71
Z-Series Metal Access Panels	72
Z-Series Metal 1 Hour Fire Rated Access Panels	73

78

RAD-SEAL

Rad-seal Face-Fix Radiator Pipe Guide & Seal - 15mm	79
Rad-seal Face-Fix Radiator Pipe Guide & Seal - 10mm	80
Rad-seal Recessed Radiator Pipe Guide & Seal	81

82

ROOFLINE

Push-In Soffit Vent	84
Soffit Vent Type C	85
Corbel Vent	86
Over Fascia Vent	87
1m Over Fascia Vent	88
Over Fascia Ventilation System	89
Rafter Roll	90
6m Eaves Vent Pack	91
Felt Support Tray	92
Eaves Comb Filler	93
Lap Vent	94
Roll Out Dry Fix Ridge Kits	96
6m Integrated Dry Ridge Kit	97
6m Roll Out Dry Fix Clay Ridge Kit	98
6m Roll Out Dry Fix Hip Kit	99
Hip Accessory Kit	100
Ambi-verge Universal Dry Fix Verge System	102
Dry Fix Verge System - Handed	104
Interlocking Plain Edge Dry Verge	106
Thin Leading Edge Dry Verge	108
Dry Fix Continuous Verge System	110
Ambi-Soaker - Plain	112
Ambi-Soaker - Interlocking Plain	113
Ambi-Soaker - Slate	114
Ambi-Soaker - Thin Leading Edge	115
Ambi-Soaker - Flat	116
PbFree Lead-free Flashing	117
MemBreathe 115gsm Breathable Membrane	118
MemBreathe 135gsm Breathable Membrane	119
MemBreathe 165gsm Breathable Membrane	120
Technical Information & Installation Advice	121
Inventive Roof Tile Vents Product Breakdown Table	124
Inventive Roof Tile Vents	125
110mm Flexi-Pipe Kits	144
Multi Stepped Duct Adapter	145
Hooded Slate Vent Adapter	146
Standard Roof Tile Vent Adapter	147
Plain Roof Tile Vent Adapter	148
Inline Slate Vent Adapter	149

150

THROUGH-WALL VENTILATION

Cavity Sleeves	151
Internal Grilles & Airbrick Cowls	152
Aero Core Anti-Draught Ventilators	154
Technical Information & Installation Advice	155

156

TOP HATS, GAS BARRIERS & DPC

Top Hats & Flexible Top Hats	157
1201 Top Hat	158
Radon Sump	159
Damp Proof Coursing Accessories	160
Gas Barrier & Damp Proof Systems & Accessories	161

163

METER BOXES

Electric Meter Box – Recessed	164
Electric Meter Box – Surface Mounted	165
Gas Meter Box – Recessed	166
Gas Meter Box – Surface Mounted	167
Gas Meter Box – Universal Smart	168
Meter Box Hockey Sticks	169
Electric 3 Phase Meter Box – Surface Mounted	170
Electric 3 Phase Meter Box – Recessed	171

172

HEDGEHOG HIGHWAY

Hedgehog Highway	172
------------------	-----

174

PRODUCT CODES

Product Codes, Lead Times & Pack Quantities	174
Replacement Parts	185
Commodity Codes	186
Terms & Conditions	192

CONSTRUCTION ACCESSORIES

Product	Page No.
Invisiweep - Wall Weep	9
Invisiweep NC - Non-Combustible Wall Weep	10
Cavity Wall Weep Vent	11
Drill Vent by Timloc	12
Insulation Retaining Discs	13
1201 Airbrick	14
1201 Telescopic Underfloor Vent	15
1201XL Telescopic Underfloor Vent	16
1201XL+ Telescopic Underfloor Vent	17
Telescopic Underfloor Vent Extension Accessories	18

SCAN
TO VIEW



**CATEGORY
GUIDE**

AVAILABLE



INVISIW P

The almost invisible wall weep

Wall weep for discharging water from external walls

Use

Any situation where water must be discharged from an external wall, e.g.:

- At ground floor slab level
- Within cavity tray systems
- Over external lintels
- On external masonry walls

Features and Benefits

- Integral 4mm vermin barrier and rainwater baffle as recommended by BS5250, to reduce ingress of large nest building insects and rainwater penetration to the cavity
- External ribs & tapered profile, to key into mortar for secured fixing
- Full height upstand to cavity side, to maintain drainage and minimise the impact on blockage from cavity cement build up
- Discrete water outlet, to minimise the impact and reduce visibility for a truly concealed wall weep
- Venturi effect outlet tube to reduce pressure, allowing for optimal water drainage
- Extension tube available for wide walls and render - IW500EX

Quality

- Manufactured to BS EN ISO 9001 and BS EN ISO 14001
- Meets British standards; BS5250, BS8000, BS5628, BS8215
- Satisfies all NHBC requirements
- Complies with all relevant Building Regulations

Technical Information

Cavity wall weeps or cavity drain units should always be installed in cavity masonry walls to allow drainage at regular intervals. They are required at ground floor, below DPC level, and must also be provided as part of any cavity tray run, including roof abutment trays, over lintels and continuous cavity tray systems, such as gas protection barrier systems.

Unfortunately, many sites are still providing a weep hole facility by simply leaving the perpend joints between bricks open, these open joints are prone to being filled.

Perpendicular joints left open can be very noticeable and result in an infestation of nest building insect and small mammals and allow the ingress of driving wind and rain, which leads to the need for a proprietary weep unit such as the Invisiweep.

Invisiweep has been designed and flow tested to optimise the discharge of water while meeting the requirement for a small concealed outlet size.

Installation Advice

- Invisiweep should be used in perpendicular joints to perform the function of a drainage channel wherever water could collect inside a cavity wall such as over external lintels, or over cavity trays
- To work effectively the Invisiweep should be placed directly on top of the base of a cavity tray, DPC or on the front edge of a lintel
- Wall weeps should be placed at 450mm centres above openings with a minimum of two to comply with NHBC recommendations
- Care should be taken to ensure the Invisiweep is kept clear of mortar and does not become blocked. This is important at the cavity side of the weep which could be blocked by mortar droppings from above
- For wide walls and render finishes, the weep tube extension can be pushed into the open end of the Invisiweep and cut to the required size.



How to Order

- To calculate quantities, divide the overall length of the cavity tray, DPC or lintel by 450mm and round up to the nearest number or by 900mm if wider centres for perimeter cavity trays
- Allow a minimum of two Invisiweeps per opening and one Invisiweep for every cavity tray stop end
- The Invisiweep is 102mm long and will cover a standard external wall, longer units can be made up on site with additional IW500EX extension
- State the product number with box quantity and colour

Materials

- Injection moulded from Polypropylene
- Invisiweep is available in Terracotta, Buff, Brown, Clear, White, Grey, Black and Blue Black
- Invisiweep Extension is available in Clear only

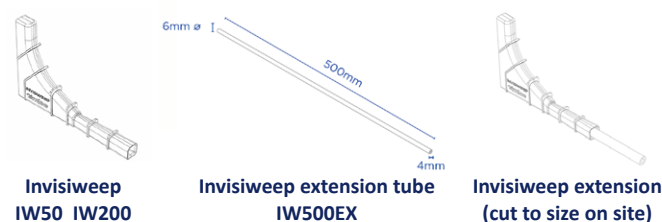
Product Codes

Description	Height	Width	Length	Pack Qty	Product Code
Invisiweep	65mm	10mm	102mm	50	IW50
Invisiweep	65mm	10mm	102mm	200	IW200
Invisiweep Extension	6mm ϕ	6mm ϕ	500mm	10	IW500EX

State required colour at the end of the product code:

TE:Terracotta, **BU:**Buff, **BR:**Brown, **CL:**Clear, **WH:**White, **GR:**Grey, **BL:**Black, **BB:**Blue Black

Product Dimensions



Invisiweep
IW50 IW200

Invisiweep extension tube
IW500EX

Invisiweep extension
(cut to size on site)



Scan to view the full product page on the Timloc website



Non-combustible wall weep for discharging water from external walls

Use

Any situation where water must be discharged from an external wall, e.g:

- In external masonry walls
- Suitable for high rise buildings above 18 metres as Regulation 7 (2) & Building Regulation approved document B
- Suitable for high rise buildings above 11 metres as Building (Scotland) technical handbook 2019: domestic and non-domestic
- At ground floor slab level
- Within cavity tray systems
- Over external lintels

Features and Benefits

- High pressure diecast in A1 non-combustible metal protected by an electroplated coating.
- Classified as A1, non-combustible, no contribution to fire without the need for testing according to European Commission paper 96/603/EC and BS EN 13501-1:2018
- Integral 4mm vermin barrier and rainwater baffle as recommended to reduce ingress of large nest building insects and rainwater penetration to the cavity
- External ribs & tapered profile, to key into mortar for secured fixing
- Full height upstand to cavity side, to maintain drainage and minimise the impact on blockage from cavity cement build up
- Discrete water outlet, to minimise the impact and reduce visibility for a truly concealed wall weep
- Venturi effect outlet tube to reduce pressure, allowing for optimal water drainage

Applications

- Suitable for use in high-rise buildings with a storey 18m or more above ground level to Regulation 7(2) and Building Regulations Approved Document B.
- Suitable for use in buildings with a storey 11m or more above ground level to Building (Scotland) technical handbook 2019: domestic and non-domestic, 2.7.

Quality

- Meets British standards; BS5250, BS8000, BS5628, BS8215
- Satisfies all NHBC requirements
- Complies with all relevant Building Regulations

Technical Information

Cavity wall weeps or cavity drain units should always be installed in cavity masonry walls to allow drainage at regular intervals. They are required at ground floor, below DPC level, and must also be provided as part of any cavity tray run, including roof abutment trays, over lintels and continuous cavity tray systems, such as gas protection barrier systems.

Unfortunately, many sites are still providing a weep hole facility by simply leaving the perpendicular joints between bricks open, these open joints are prone to being filled.

Perpendicular joints left open can be very noticeable and result in an infestation of nest building insect and small mammals and allow the ingress of driving wind and rain, which leads to the need for a proprietary weep unit such as the Invisiweep.

Invisiweep NC has been designed and flow tested to optimise the discharge of water while meeting the requirement for a small concealed outlet size.



Installation Advice

- Invisiweep NC should be used in perpendicular joints to perform the function of a drainage channel wherever water could collect inside a cavity wall such as over external lintels, or over cavity trays
- To work effectively the Invisiweep NC should be placed directly on top of the base of a cavity tray, DPC or on the front edge of a lintel
- Wall weeps should be placed at 450mm centres above openings with a minimum of two to comply with NHBC recommendations. Care should be taken to ensure the Invisiweep NC is kept clear of mortar and does not become blocked. This is important at the cavity side of the weep which could be blocked by mortar droppings from above

How to Order

- To calculate quantities, divide the overall length of the cavity tray, DPC or lintel by 450mm and round up to the nearest number or by 900mm if wider centres for perimeter cavity trays
- Allow a minimum of two Invisiweep NCs per opening and one Invisiweep NC for every cavity tray stop end
- State the product code

Materials

- Electroplated high pressure diecast Zinc alloy

Product Code

Description	Height	Width	Length	Pack Qty	Product Code
Invisiweep NC	65mm	10mm	102mm	50	ZIN50



Scan to view the full product page on the Timloc website

Cavity Wall Weep Vent

Multi-function weep for discharging water from external walls and cavity ventilation

Use

Any situation where water must be discharged from an external wall, e.g:

- At ground floor slab level
- Within cavity tray systems
- Over external lintels
- Where a cavity must be ventilated
- On external walls - 100mm or more in thickness
- built from brick, block or stone

Features and Benefits

- Purpose made and pre-formed to guarantee reliable discharge of water
- Less prone to inadvertent pointing-up than weep holes formed by simply leaving the perp. joint open
- Integral front grille prevents entry of large nest building insects into the cavity when using product 1143
- Range of colours to blend with brick or mortar colour: Terracotta, Buff, Brown, Clear, White, Grey, Black or Blue Black
- Individual extension pieces (1144) can be clipped together to create a longer extension
- 1143 airflow = 165mm² Free area/unit

Quality

- Satisfies all NHBC requirements
- Manufactured to BS EN ISO 9001 and BS EN ISO 14001
- Complies with all relevant Building Regulations
- Meets all relevant British Standards

Material and Colour Choice

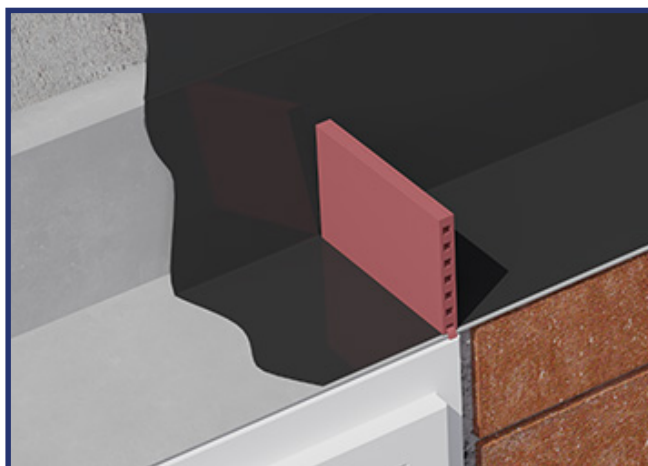
- 1143 is injection moulded in UV stabilised polypropylene
- 1143 is available in a choice of Terracotta, Buff, Brown, Clear, White, Grey, Black or Blue Black
- 1144 is available in Natural only

Installation Advice

- Wall weep vents should be used wherever water could collect inside a cavity wall, such as over external lintels, or wherever a cavity tray system is installed
- To work effectively wall weep vents should be placed directly on top of the base of a cavity tray or DPC, or on the front flange of the lintel
- Wall weep vents should be spaced at 450mm centres to comply with NHBC recommendations
- Care should be taken to ensure the wall weep vent is kept clear of mortar and does not become blocked. This is particularly important at the back of the weep vent which could be blocked by mortar droppings from above.

How to Order

- To calculate quantities divide the overall length of the cavity tray, DPC or lintel by 450mm and round up to the nearest whole number
- Check that the external wall is a standard 102.5mm brick or 100mm block thickness, if it is not please state the thickness on your order
- State the product number, type, colour etc. on your order



Bill of Quantity

F30 Accessories/sundry items for brick/block/stone walling
Clause

132^ WEEP HOLES

- Form with plastics perpend units to manufacturers recommendations at not greater than 900mm centres immediately above base of cavity, external openings and stepped dpcs. Provide not less than two weep holes over openings.
- Manufacturer: Timloc Building Products, Timloc House, Ozone Park, Howden, East Yorkshire, DN14 7SD. T: 01405 765567 W: www.timloc.co.uk
- Reference: 1143/1144
- Colour: Terracotta, Buff, Brown, Clear, White, Grey, Black or Blue Black

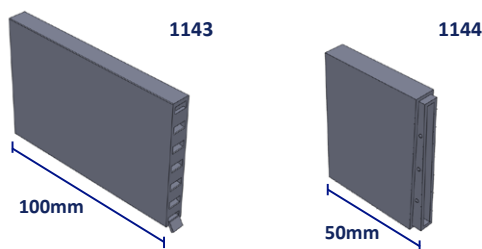
Product Codes

Description	Height	Width	Length	Pack Qty	Product Code
Cavity Wall Weep Vent	65mm	10mm	100mm	50	1143
Extension Piece	65mm	10mm	50mm	50	1144

State required colour at the end of the 1143 product code:

TE:Terracotta, **BU:**Buff, **BR:**Brown, **CL:**Clear, **WH:**White, **GR:**Grey, **BL:**Black, **BB:**Blue Black

Product Dimensions



Scan to view the full product page on the Timloc website

Drill Vent by Timloc

Cavity ventilator and drainage weep

Use

- When cavity ventilation and/or drainage is required to an external cavity wall
- Ideal solution for retro-fitting
- Designed with high airflow for venting timber framed buildings
- Suitable for high & low-level cavity wall ventilation & drainage applications
- Perfect for rendered masonry walls

Features and Benefits

- Purpose made and pre-formed to guarantee reliable ventilation
- Quick and easy to install in a 25mm diameter drilled hole
- Circular design allows efficient ventilation airflow of 335mm²
- Integral curved louvres are designed to maximise airflow and reduce entry of wind driven rain
- Louvres designed to prevent entry of large nest building insects into the cavity
- Large low-level drainage hole
- Barbed body ensures secure fit into pre-drilled hole
- Outer flange to offer clean finish
- Range of colours to blend with brick or mortar colour (Clear, Buff, Terracotta)

Quality

- Satisfies all relevant NHBC Standards for cavity ventilation & drainage
- Manufactured to BS EN ISO 9001
- Complies with all relevant Building Regulations
- Meets all relevant British Standards

Material and Colour Choice

- Manufactured from polypropylene
- Drill vents are available in a choice of Clear, Buff and Terracotta

Installation Advice

- To meet NHBC standards for cavity ventilation in external timber framed walls, fit each ventilator at 600mm centres
- To meet The Building (Scotland) Regulations for ventilating cavities within masonry outer leaf walls, fit each ventilator at 1200mm centres
- To meet Building Regulations Part C for external wall cavity drainage at low level, fit each unit at 900mm centres
- To form a weep hole to drain cavity trays install each unit at 450mm centres above openings and 900mm centres to other areas
- High level vents are located externally 200 – 225mm below the soffit or roof barge. Low level vents should be installed by the DPC at ground level. At this level, it doubles as a drain for the cavity as well as a vent
- If the cavity is bridged or closed at intermediate floor levels, cavity venting and drainage should be provided above and below the bridge
- Identify the location at which you need to place the vent. A 25mm hole is cored at spacing centres required
- The vent has been designed to be installed at a slight angle (approx. 2.5°), to minimize any wind-driven rain entering the cavity and allow the unit to drain freely. Therefore, the hole is drilled through the external leaf with the drill inclined slightly upwards. It is recommended to use a drill with a depth setting as to avoid any damage to the internal leaf, insulation or breather membranes
- Insert and align the ventilator into the hole and tap into place using a rubber mallet. The ventilator should finish flush with the wall surface.

How to Order

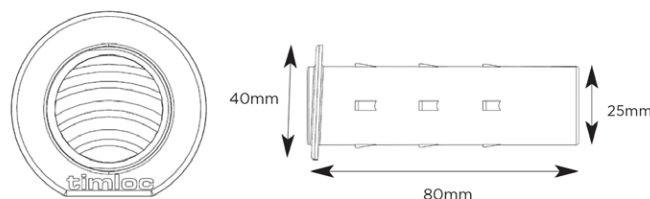
- Calculate quantity required based upon application
- State the product code
- Supplied in pack quantities of 50



Product Codes

Description	Colour	Hole ϕ	Pack Qty	Product Code
Drill Vent	Clear	25mm ϕ	50	DV1
Drill Vent	Buff	25mm ϕ	50	DV2
Drill Vent	Terracotta	25mm ϕ	50	DV3

Product Dimensions



Scan to view the full product page
on the Timloc website

Insulation Retaining Discs

A universal insulation retaining disc to suit most styles and sizes of wall tie

Use

- A universally designed insulation retaining disc
- Suitable for general purpose, light duty and heavy duty applications

Features and Benefits

- Will fit most wall ties available from leading wall tie manufacturers
- Suitable for both fibre and rigid slab insulation
- Firm grip design that will not move on the wall tie

Quality

- Satisfies all NHBC requirements
- Manufactured to BS EN ISO 9001 and BS EN ISO 14001
- Complies with all relevant Building Regulations
- Meets all relevant British Standards

Material and Colour Choice

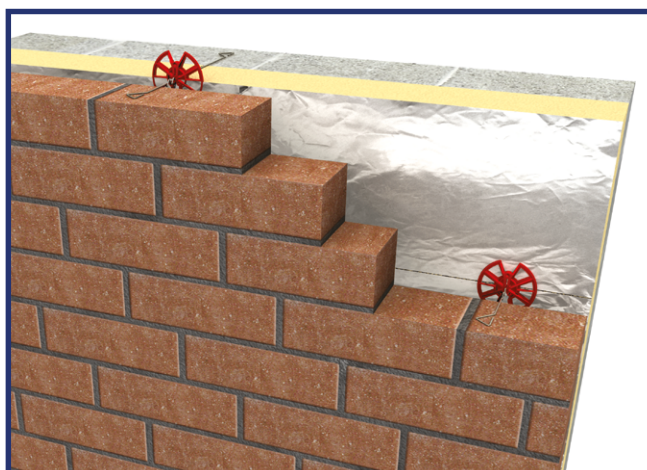
- Manufactured from polypropylene
- Available in Red or Black

Installation Advice

- Insulation retaining discs should be fitted to every wall tie for applications when insulation retainers are required
- Spacing and quantity calculations should be as wall tie guidance
- Consult latest NHBC Standards for required spacing
- 'Where partial cavity fill is to be used,' ties/discs should be spaced at 600mm centres horizontally and in vertical as well as horizontal rows, ie not staggered
- Retaining discs are clipped onto wall ties either before building in or in situ
- Due to the firm grip design the disc may require opening slightly to accept the wall tie
- It is recommended that the wall tie is held in position when the disc is offered and clipped in place

How to Order

- Typically one disc per wall tie. Approximately 5 per square metre
- State the product code
- Supplied in pack quantities of:
1500 - **IRD65BL**
1000 - **IRD80R**



Product Codes

Description	Colour	Diameter	Pack Qty	Product Code
Insulation Retaining Disc	Black	65mm	1500	IRD65BL
Insulation Retaining Disc	Red	80mm	1000	IRD80R



Scan to view the full product page on the Timloc website

Airbrick

Airbrick ventilator available in a range of colours

Use

- In conjunction with the 1201 / 1201XL telescopic underfloor vent for providing ventilation below suspended ground floors
- In conjunction with cavity sleeves for ventilation through external walls to a building interior

Features and Benefits

- Equivalent area of 6170mm² per air brick
- Unique stepped front grille greatly reduces the entry of wind driven rain
- 6.5mm wide front grille openings comply with BS 5440 Pt 2 and British Gas requirements
- Integral clip together facility allows multiple airbricks to be stacked to form 9" x 6" and 9" x 9" sizes
- Available in a range of colours to blend in with various brick types
- Very tough and robust
- Durable and totally resistant to decay

Quality

- Satisfies all NHBC requirements
- Manufactured to BS EN ISO 9001 and BS EN ISO 14001
- Complies with all relevant Building Regulations
- Meets all relevant British Standards
- Equivalent area marking to front face of airbrick to comply with BS EN 13141-1 : 2004

Material and Colour Choice

- Manufactured by injection moulding in UV stabilised polypropylene
- 1201 airbrick is available in Buff, Terracotta, Grey, Brown, Black, White and Blue Black.

Installation Advice

- Always use in conjunction with a Timloc telescopic underfloor ventilator, or cavity sleeve, depending on the application

How to Order

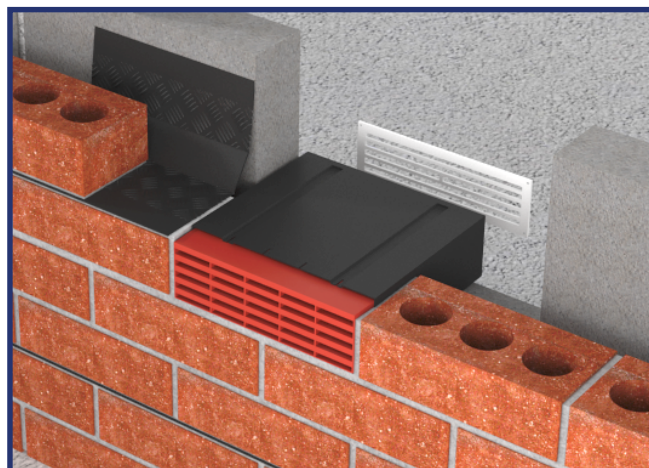
- Airbrick quantity will be relative to the number of telescopic underfloor ventilators or cavity sleeves required
- State the colour required

Bill of Quantity

F30 Accessories/sundry items for brick/block/stone walling
Clause

160 | AIRBRICK

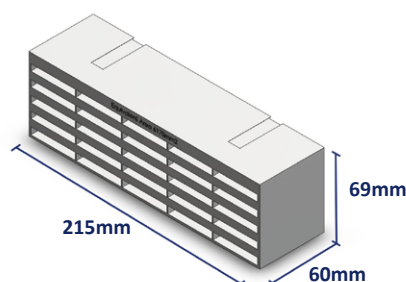
- To BS493, Class 1, built in as the work proceeds.
- Manufacturer: Timloc Building Products, Timloc House, Ozone Park, Howden, East Yorkshire, DN14 7SD. T: 01405 765567, W: www.timloc.co.uk
- Reference: 1201AB
- Design: Rectangular
- Work size: Each unit 69mm coursing x 215mm, (Equivalent area 6170mm²)
- Material: Thermoplastic
- Colour: (Black, White, Brown, Buff, Grey, Blue Black or Terracotta)
- Optional Accessories: e.g. 1201 Telescopic Under Floor Vent (6,500mm² with Airbrick)



Product Codes

Description	Colour	Equivalent Area	Pack Qty	Product Code
Airbrick	Blue Black	6170mm ²	20	1201ABBB
Airbrick	Black	6170mm ²	20	1201ABBL
Airbrick	Brown	6170mm ²	20	1201ABBR
Airbrick	Buff	6170mm ²	20	1201ABBU
Airbrick	Grey	6170mm ²	20	1201ABGR
Airbrick	Terracotta	6170mm ²	20	1201ABTE
Airbrick	White	6170mm ²	20	1201ABWH

Product Dimensions



Scan to view the full product page on the Timloc website

1201 Telescopic Underfloor Ventilator

Adjustable ventilator for 3-5 brick courses

Use

- To provide ventilation below suspended ground floors

Features and Benefits

- Telescopic and adjustable for a step of 3, 4 or 5 brick courses
- Suited for 50-100mm cavity width construction
- Horizontal and vertical extension accessories available
- Free area of 8000mm² per unit when installed without 1201AB airbrick
- Free area of 6500mm² per unit when installed with 1201AB airbrick
- Equivalent area of 6170mm² per unit when installed with 1201AB airbrick
- Special grille included to prevent entry of vermin
- Durable, robust and totally resistant to decay

Quality

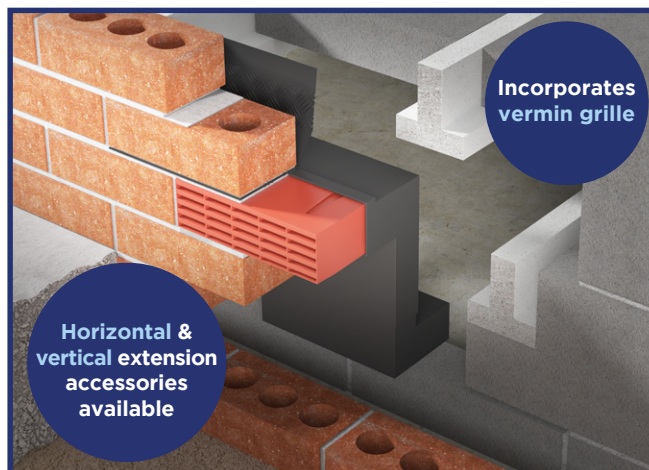
- Satisfies all NHBC requirements
- Manufactured to BS EN ISO 9001 and BS EN ISO 14001
- Complies with all relevant Building Regulations
- Meets all relevant British Standards

Material and Colour Choice

- Manufactured by injection moulding in polypropylene
- Available in black only

Installation Advice

- Always use in conjunction with a 1201AB airbrick from Timloc
- The airbrick and upper front opening of the telescopic underfloor ventilator must be positioned above the finished external ground level - usually at the same level as the ground level DPC
- The lower rear opening of the product must project down to the level of the underfloor void and must not be obstructed by the floor construction. A vertical extension sleeve is available to fit with this product if the standard 5 course step is not adequate
- Building Regulations require a free airflow below suspended ground floors of at least 1500mm² per metre run of wall. This can be achieved by spacing the ventilators at 4m centres, however, such a wide spacing is not recommended as stagnant air pockets could form in the underfloor void. Timloc recommend a spacing of not more than 2m centres to comply with NHBC standards.
- The NHBC recommend that underfloor ventilators are spaced at a maximum of 2m centres, with ventilators also positioned not more than 450mm from the ends of the wall
- As a minimum requirement ventilators should be positioned down two opposite sides of the building to create a cross flow ventilation action. It is good practice to position ventilators around the full perimeter of the building, particularly with complex building designs
- If the underfloor void is separated by dividing walls, openings must be provided to allow a free flow of air around the underfloor void
- The standard ventilator will fit into a cavity wall with an external leaf of 100-102.5mm, a minimum cavity width of 50mm and a cross cavity of 100mm. External and internal horizontal extension sleeves are available to accommodate thicker walls or wider cavities
- To be installed with a DPC Cavity tray and wall weeps to collect any water ingress. We recommend Timloc's IL4 and 2 weeps (Invisiweep or 1143)
- When incorporating with a gas barrier system and adjusted to the required height, the joining sections should be sealed with proprietary tape
- It may be a requirement to protect with a lintel for direct loads



Bill of Quantity

F30 Accessories/sundry items for brick/block/stone walling
Clause

160 | AIRBRICK

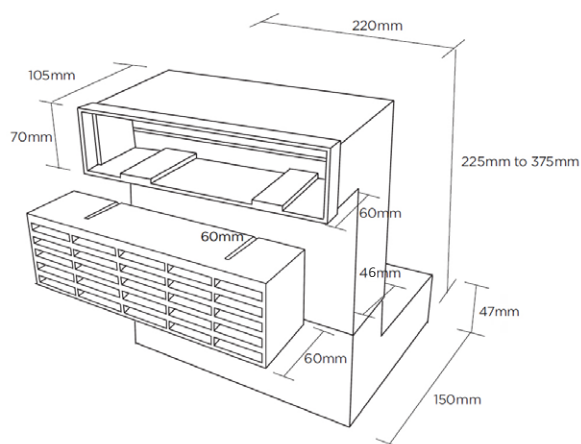
- To BS493, Class 1, built in as the work proceeds.
- Manufacturer: Timloc Building Products, Timloc House, Ozone Park, Howden, East Yorkshire, DN14 7SD. T: 01405 765567 W: www.timloc.co.uk
- Reference: 1201 Telescopic Underfloor Ventilator
- Design: Rectangular
- Work size: Each unit 225/375mm coursing x 220mm
- Material: Thermoplastic
- Colour: Black
- Optional Accessories:
 - 1203 Horizontal Front Extension (+115mm)
 - 1204 Vertical Extension Sleeve (additional 2 brick courses)
 - 1205 Duct Adaptor (suits 110mm diameter duct)
 - 1206 Horizontal Rear Extension (+100mm)

Product Codes

Description	Coursing Height	Pack Qty	Product Code
Telescopic Underfloor Vent	3-5 courses	20	1201

N.B. The 1201 is designed for use with a 1201AB airbrick. It can also be used with a clay airbrick but this will reduce the overall airflow.

Product Dimensions



Scan to view the full product page
on the Timloc website

1201XL

Adjustable ventilator for up to 7 brick courses

Use

- To provide ventilation below suspended ground floors

Features and Benefits

- Telescopic and adjustable for a step of 5, 6 or 7 brick courses
- Suited for 50-150mm cavity width construction
- Horizontal and vertical extension accessories available
- Free area of 8000mm² per unit when installed without 1201AB airbrick
- Free area of 6500mm² per unit when installed with 1201AB airbrick
- Equivalent area of 6170mm² per unit when installed with 1201AB airbrick
- Special grille included to prevent entry of vermin
- Durable, robust and totally resistant to decay

Quality

- Satisfies all NHBC requirements
- Manufactured to BS EN ISO 9001 and BS EN ISO 14001
- Complies with all relevant Building Regulations
- Meets all relevant British Standards

Material and Colour Choice

- Manufactured by injection moulding in polypropylene
- Available in black only

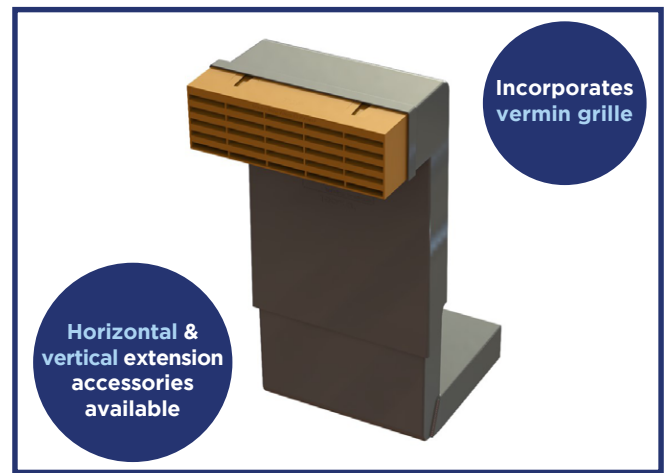
Installation Advice

- Always use in conjunction with a Timloc airbrick
- The airbrick and upper front opening of the telescopic underfloor ventilator must be positioned above the finished external ground level - usually at the same level as the ground level DPC
- The lower rear opening of the product must project down to the level of the underfloor void and must not be obstructed by the floor construction. A vertical extension sleeve is available to fit with this product if the standard 7 course step is not adequate
- Building Regulations require a free airflow below suspended ground floors of at least 1500mm² per metre run of wall. This can be achieved by spacing the ventilators at 4m centres, however, such a wide spacing is not recommended as stagnant air pockets could form in the underfloor void. Timloc recommend a spacing of not more than 2m centres to comply with NHBC standards.
- The NHBC recommend that underfloor ventilators are spaced at a maximum of 2m centres, with ventilators also positioned not more than 450mm from the ends of the wall
- As a minimum requirement ventilators should be positioned down two opposite sides of the building so as to create a cross flow ventilation action. It is good practice to position ventilators around the full perimeter of the building, particularly with complex building designs
- If the underfloor void is separated by dividing walls, openings must be provided to allow a free flow of air around the underfloor void
- The standard ventilator will fit into a cavity wall with an external leaf of 100-102.5mm, a minimum cavity width of 50mm and across a cavity of 150mm. External and internal horizontal extension sleeves are available to accommodate thicker walls or wider cavities
- To be installed with a DPC Cavity tray and wall weeps to collect any water ingress. We recommend Timloc's IL4 and 2 weeps (Invisiweep or 1143)
- When incorporating with a gas barrier system and adjusted to the required height, the joining sections should be sealed with proprietary tape.
- It may be a requirement to protect with a lintel for direct loads

N.B. The 1201XL is designed for use with a 1201AB airbrick. It can be used with a clay airbrick but this will reduce the overall airflow.

How to Order

- Measure the length of each wall requiring telescopic underfloor ventilators and divide by 2m to establish the quantity required
- Always round up if the calculation does not work out to an exact whole number
- To be installed with a DPC cavity tray and wall weeps to collect any water ingress. We recommend Timloc's IL4 and 2 weeps (Invisiweep or 1143)



Bill of Quantity

F30 Accessories/sundry items for brick/block/stone walling
Clause

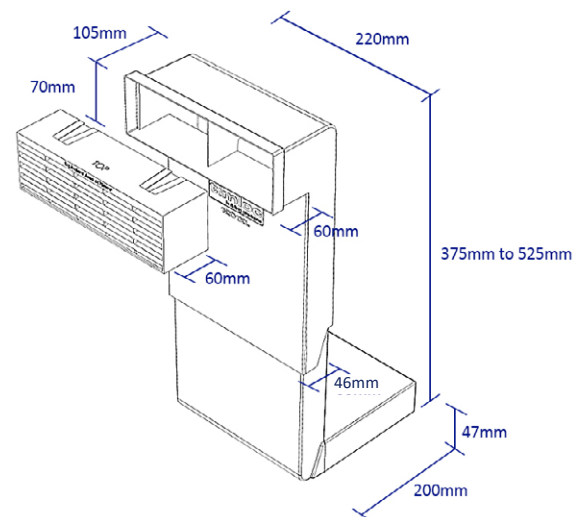
160 | AIRBRICK

- To BS493, Class 1, built in as the work proceeds.
- Manufacturer: Timloc Building Products, Timloc House, Ozone Park, Howden, East Yorkshire, DN14 7SD. T: 01405 765567, W: www.timloc.co.uk
- Reference: 1201XL Telescopic Underfloor Ventilator
- Design: Rectangular
- Work size: Each unit 375/525mm coursing x 220mm
- Material: Thermoplastic
- Colour: Black
- Optional Accessories:
 - 1203 Horizontal Front Extension (+115mm)
 - 1204 Vertical Extension Sleeve (additional 2 brick courses)
 - 1205 Duct Adaptor (suits 110mm diameter duct)
 - 1206 Horizontal Rear Extension (+100mm)

Product Code

Description	Coursing Height	Pack Qty	Product Code
Telescopic Underfloor Vent	5-7 courses	10	1201XL

Product Dimensions



Scan to view the full product page
on the Timloc website

1201XL+

Adjustable ventilator for up to 7 brick courses

Use

- To provide ventilation below suspended ground floors

Features and Benefits

- Telescopic and adjustable for a step of 5, 6 or 7 brick courses
- Suited for 50-150mm+ cavity width construction
- Also compatible down to 50mm clear cavity width
- Horizontal and vertical extension accessories available
- Free area of 8000mm² per unit when installed without airbrick
- Free area of 6500mm² per unit when installed with 1201AB airbrick
- Equivalent area of 6170mm² per unit when installed with 1201AB airbrick
- Durable, robust and totally resistant to decay

Quality

- Satisfies all NHBC requirements
- Manufactured to BS EN ISO 9001 and BS EN ISO 14001
- Complies with all relevant Building Regulations
- Meets all relevant British Standards

Material and Colour Choice

- Manufactured by injection moulding in polypropylene
- Available in black only

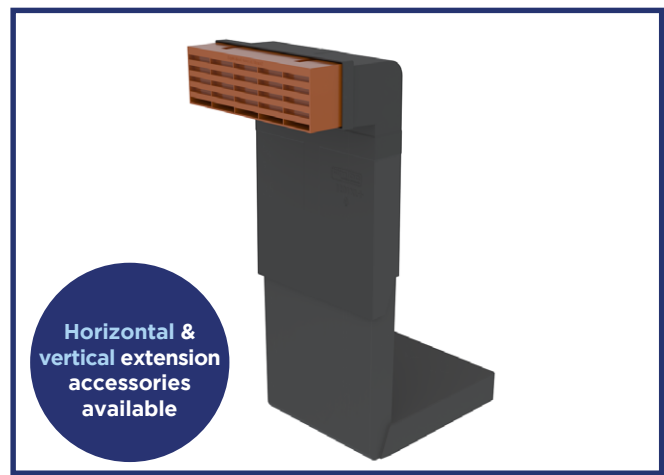
Installation Advice

- Always use in conjunction with a Timloc airbrick
- The airbrick and upper front opening of the telescopic underfloor ventilator must be positioned above the finished external ground level - usually at the same level as the ground level DPC
- The lower rear opening of the product must project down to the level of the underfloor void and must not be obstructed by the floor construction. A vertical extension sleeve is available to fit with this product if the standard 7 course step is not adequate
- Building Regulations require a free airflow below suspended ground floors of at least 1500mm² per metre run of wall. This can be achieved by spacing the ventilators at 4m centres, however, such a wide spacing is not recommended as stagnant air pockets could form in the underfloor void. Timloc recommend a spacing of not more than 2m centres to comply with NHBC standards.
- The NHBC recommend that underfloor ventilators are spaced at a maximum of 2m centres, with ventilators also positioned not more than 450mm from the ends of the wall
- As a minimum requirement ventilators should be positioned down two opposite sides of the building so as to create a cross flow ventilation action. It is good practice to position ventilators around the full perimeter of the building, particularly with complex building designs
- If the underfloor void is separated by dividing walls, openings must be provided to allow a free flow of air around the underfloor void
- The standard ventilator will fit into a cavity wall with an external leaf of 100-102.5mm, a minimum cavity width of 50mm and across a cavity of 150mm plus internal 100mm. External and internal horizontal extension sleeves are available to accommodate thicker walls or wider cavities
- To be installed with a DPC Cavity tray and wall weeps to collect any water ingress. We recommend Timloc's IL4 and 2 weeps (IW or 1143)
- It may be a requirement to protect with a lintel for direct loads

N.B. The 1201XL+ is designed for use with a 1201AB airbrick. It can be used with a clay airbrick but this will reduce the overall airflow.

How to Order

- Measure the length of each wall requiring telescopic underfloor ventilators and divide by 2m to establish the quantity required
- Always round up if the calculation does not work out to an exact whole number
- To be installed with a DPC cavity tray and wall weeps to collect any water ingress. We recommend Timloc's IL4 and 2 weeps (Invisiweep or 1143)



Bill of Quantity

F30 Accessories/sundry items for brick/block/stone walling
Clause

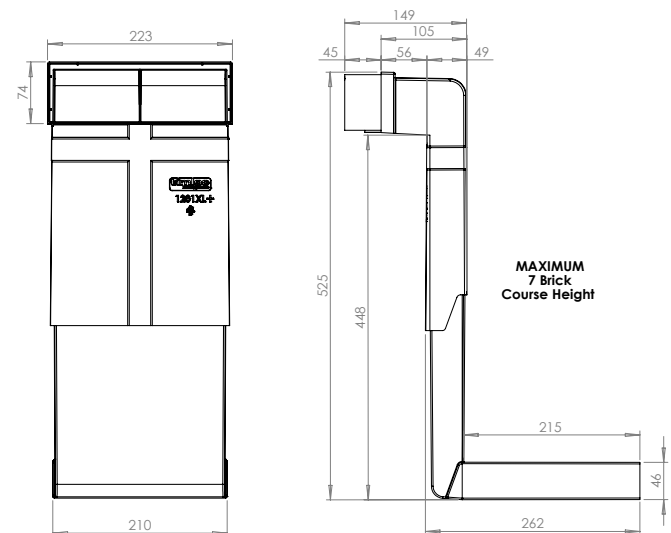
160 | AIRBRICK

- To BS493, Class 1, built in as the work proceeds.
- Manufacturer: Timloc Building Products, Timloc House, Ozone Park, Howden, East Yorkshire, DN14 7SD. T: 01405 765567, W: www.timloc.co.uk
- Reference: 1201XL+ Telescopic Underfloor Ventilator
- Design: Rectangular
- Work size: Each unit 375/525mm coursing x 220mm
- Material: Thermoplastic
- Colour: Black
- Optional Accessories:
 - 1203 Horizontal Front Extension (+115mm)
 - 1204 Vertical Extension Sleeve (additional 2 brick courses)
 - 1205 Duct Adaptor (suits 110mm diameter duct)
 - 1206 Horizontal Rear Extension (+100mm)

Product Code

Description	Coursing Height	Pack Qty	Product Code
Telescopic Underfloor Vent	5-7 courses	10	1201XLPLUS

Product Dimensions



Scan to view the full product page
on the Timloc website

Telescopic Underfloor Vent Extension Accessories

Accessories for various underfloor ventilation applications for 1201 / 1201XL / 1201XL+

Use

- To provide horizontal or vertical extension to a telescopic underfloor ventilator to accommodate different wall/cavity/brick courses etc.
- To connect the ventilator to a duct

Features and Benefits

- Does not restrict airflow through the main telescopic underfloor vent
- Purpose-made accessories eliminate the need for on site modifications
- Lightweight and easy to handle
- Durable and totally resistant to decay

Quality

- Satisfies all NHBC requirements
- Manufactured to BS EN ISO 9001 and BS EN ISO 14001
- Complies with all relevant Building Regulations
- Meets all relevant British Standards

Material and Colour Choice

- All accessories are injection moulded in polypropylene
- All accessories are available in black only

Products in the System

Horizontal front extension sleeve - 1203

- Fits between the airbrick and upper front opening of the telescopic underfloor ventilator to accommodate external walls of more than 102.5mm thickness, up to a maximum of 215mm.

Vertical extension sleeve - 1204

- Fits between the upper and lower parts of the telescopic underfloor ventilator to accommodate a vertical step of 6 to 7 brick courses.

Duct adaptor - 1205

- Fits on to the lower rear opening of the telescopic underfloor ventilator to allow a standard 110mm external diameter plastic underground drainage pipe to be connected via a coupling connection.

Horizontal rear extension sleeve - 1206

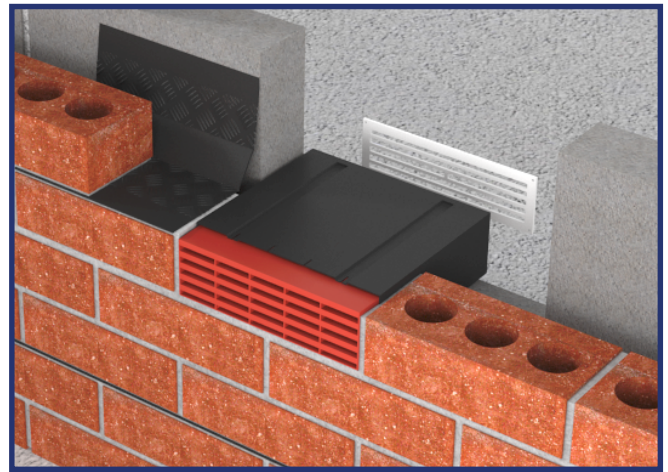
- Fits into the lower rear opening of the telescopic underfloor ventilator to accommodate cavity widths between 50-150mm - or internal walls of more than 100mm thickness, up to a maximum of 200mm

Installation Advice

- 1203 should be fitted with the slotted end to accept the airbrick. 1203 sleeves can also be slotted together to form longer sections if required
- 1204 fits externally over the upper and lower parts of the ventilator, units can be multi stacked for greater height
- 1205 has a 'push-fit' opening for the drainage pipe. The vermin grille of the ventilator can be left in position. For fitting to drainage pipe a coupling will be required
- 1206 fits over the lower rear opening of the ventilator. The vermin grille must be removed to allow this & replaced at the other end of the extension sleeve. 1206s can be slotted together to form longer sections
- To improve joins between the telescopic underfloor ventilator and an accessory, seal using insulating tape or duct tape
- When incorporating with a gas barrier system and adjusted to the required height, the joining sections should be sealed with proprietary tape

How to Order

- Establish which part of the telescopic underfloor ventilator needs extending and specify the appropriate accessory



Bill of Quantity

F30 Accessories/sundry items for brick/block/stone walling
Clause

160 | AIRBRICK

- To BS493, Class 1, built in as the work proceeds.
- Manufacturer: Timloc Building Products, Timloc House, Ozone Park, Howden, East Yorkshire, DN14 7SD. T: 01405 765567, W: www.timloc.co.uk
- Reference: Accessories
- Design: Various
- Work size: Various
- Material: Thermoplastic
- Colour: Black
- Optional Accessories:
 - 1203 Horizontal Front Extension (+115mm)
 - 1204 Vertical Extension Sleeve (additional 2 brick courses)
 - 1205 Duct Adaptor (suits 110mm diameter duct)
 - 1206 Horizontal Rear Extension (+100mm)

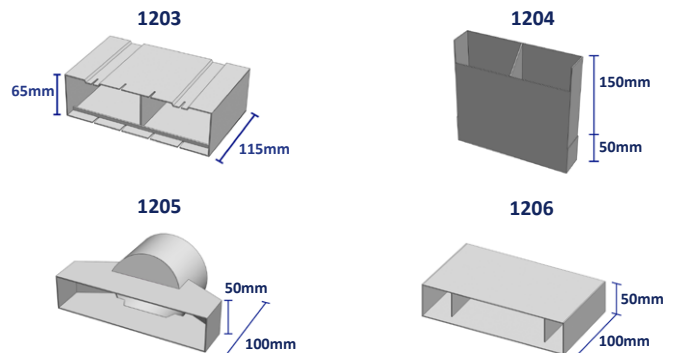
The table below shows how the build up of telescopic underfloor ventilators and vertical extension pieces achieve the required building in height.

Description	Brick Height	Rise (mm)
1201 telescopic underfloor vent	3-5	225/375
+1 no. 1204 vertical extension sleeve	6-7	450/525
+2 no. 1204 vertical extension sleeves	8-9	600/675
+3 no. 1204 vertical extension sleeves	10-11	750/825
+4 no. 1204 vertical extension sleeves	12-13	900/975

Product Codes

Description	To Suit	Product Code
Horizontal front extension	+115mm	1203
Vertical extension sleeve	Additional 2 brick courses	1204
Duct adaptor	Suits 110mm diameter duct	1205
Horizontal rear extension	+100mm	1206

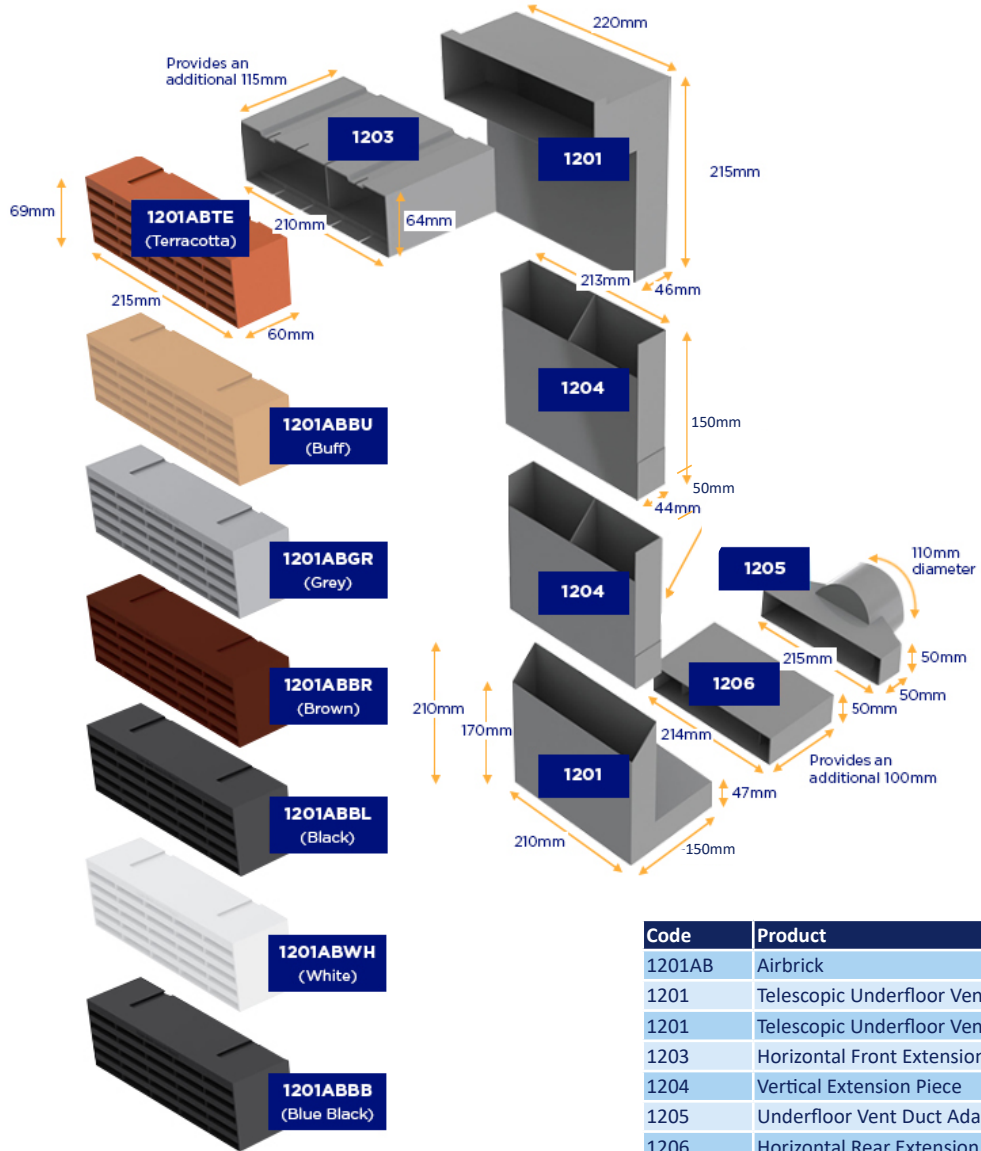
Product Dimensions



Scan to view the full product page
on the Timloc website

Telescopic Underfloor Vent Extension Accessories

Accessories for various underfloor ventilation applications for 1201 / 1201XL / 1201XL+



CAVITY TRAYS

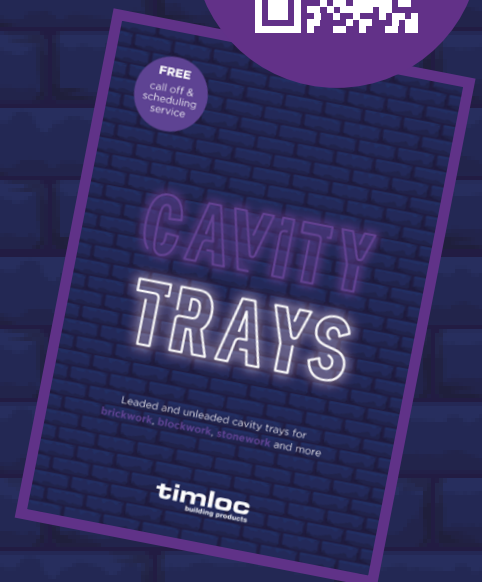
Product	Page No.
Everdry Adjustable Stepped Cavity Trays for Brickwork	22
Everdry Stepped Cavity Trays for Stonework	24
Everdry Stepped Cavity Trays for Blockwork	26
Everdry Stepped Cavity Trays for Brickwork - Lead Attached	28
Everdry Stepped Cavity Trays for Stonework - Lead Attached	30
Everdry Stepped Cavity Trays for Blockwork - Lead Attached	32
Inter-loc Horizontal Cavity Trays	34
System 2000 Horizontal Cavity Trays	36
System 2000E Horizontal Cavity Trays for Refurbishment	37
Inter-loc Horizontal Cavity Trays - Lead Attached	38
System 2000 Horizontal Cavity Trays - Lead Attached	39
Over Lintel and Parapet Cavity Trays	40
Purpose Made Cavity Trays	41
Cavity Trays for Door and Window Openings	42
Lintel Stopend	43
Technical Information & Installation Advice	44

SCAN
TO VIEW

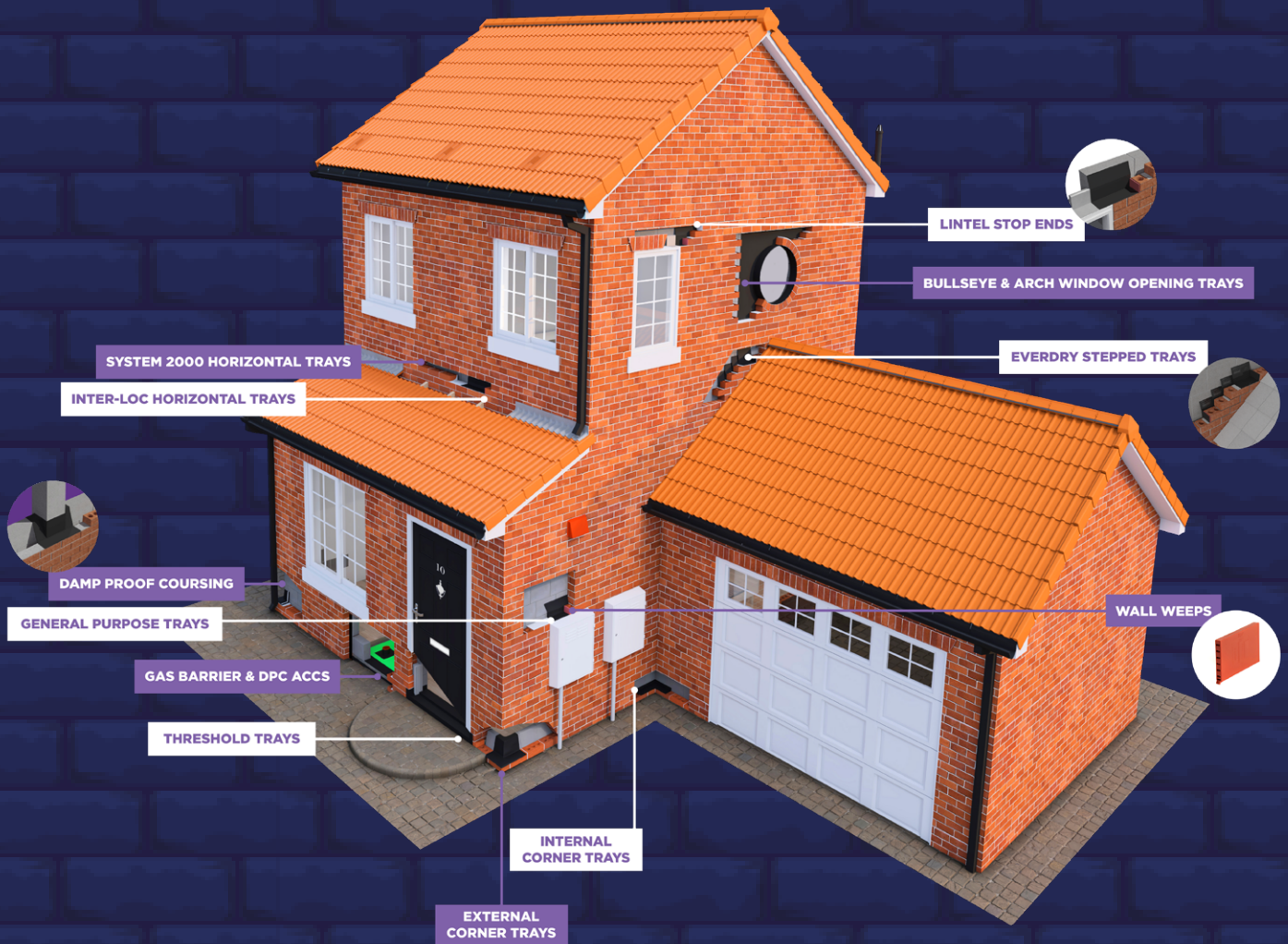


**CATEGORY
GUIDE**

AVAILABLE



At Timloc, we offer a wide range of preformed leaded and unleaded cavity trays to meet almost any application requirement and masonry type. We also have a wealth of experience in designing and manufacturing non-standard cavity trays to suit project requirements. Our cavity tray service comes with free product specification and project scheduling. Plot-specific delivery consignments are also available as needed.



Free **product specification** & scheduling

House **plot-specific** delivery available

Various ranges to suit an assortment of abutments

Leaded & unleaded options - long & short lead available

Next day delivery on all standard products

Installation & legislation guidance available

Contact Technical: **01405 765 567** | technical@timloc.co.uk

Everdry Adjustable Stepped Cavity Trays for Brickwork

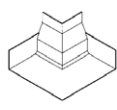
Stepped cavity tray system for multi cavity options in brick wall construction of 75mm course heights



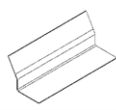
Intermediate tray (LH)



Stopend starter tray (LH/RH)



Corner starter tray (LH/RH)



Ridge tray



Use

- At the abutment of a pitched roof with a cavity wall
- On external walls - not exceeding 120mm thickness - built from standard brickwork or similar sized components with regular course heights, including mortar of approx. 75mm
- On roof pitches of 15 degrees and above
- Clear cavity widths of between 50mm-110mm
- For wider cavity widths contact Timloc Technical

Features and Benefits

- High adjustable back upstand
- Adjustable upstand to cover 50mm-110mm clear cavities
- Roof pitch marks on tray upstand to give installation guidance
- Cavity tray builds into outer leaf only to speed up installation and allowing both inner and outer leaves to be built independently if required
- Optional longer tray for roof pitches less than 25 degrees
- The system is available on request with pre-applied polystyrene strips. Polystyrene is much easier to rake out than mortar and offers a visual locator of the cavity tray so aiding the installation of post fitted lead work. (This service may incur additional charge)

Quality

- BBA approved
- Satisfies all NHBC requirements
- Manufactured to BS EN ISO 9001 and BS EN ISO 14001
- Complies with all relevant Building Regulations
- Meets all relevant British Standards

Material and Colour Choice

- All components in the range are injection moulded in 2mm polypropylene for added durability, toughness and quality
- Available in black only

Products in the Range

Intermediate trays

Suits all cavity options - forms main tray run with one tray on each course of brickwork running the full length of the abutting roof slope.

Stopend starters

First component to be installed and fitted at the lowest point on a standard abutment. It collects water gathered by the rest of the system and discharges it from the wall through a weep unit.

Corner starter trays

Has the same function as stopend starter tray but is used where the abutting roof comes up to, or beyond, the corner of the main building. Designed to return around the corner of the building to provide complete protection.

Ridge trays

Used where a right hand and left hand roof slope come together at an apex to straddle the top two intermediate trays.

Installation Advice

- The core tray will suit clear cavity widths of 50mm-110mm
- Weep holes in starter and corner starter trays can be formed simply by installing purpose made Timloc plastic wall weep units (1143/Invisiweep)
- Trays and/or where particularly porous facing brickwork is used, it is strongly recommended that extra weep holes are provided at intermediate points along the run of cavity trays.
- Many components come in left or right handed versions. Handing is dictated by the direction of the abutting roof slope.
- Trays must always be bedded onto fresh mortar, never dry bedded.
- With pre-formed cavity trays such as Everdry it is not strictly necessary for the cavity tray to span all the way across the cavity. As long as the cavity tray stands back from the rear face of the stone and projects back into the cavity far enough to intercept drips falling from the wall ties, then it will perform effectively.

Bill of Quantity

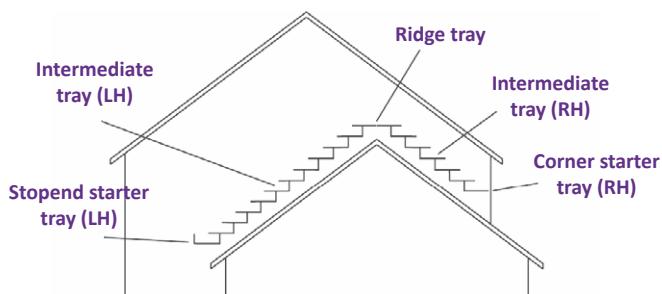
F30 Accessories/sundry items for brick/block/stone walling Clause

370 | PREFORMED CAVITY TRAY / ACCESSORIES

- Manufacturer: Timloc Building Products, Timloc House, Ozone Park, Howden, East Yorkshire, DN14 7SD. T: 01405 765567 W: www.timloc.co.uk
- Type(s) and location(s): Cavity tray to be installed into brickwork over stepped/sloping roof abutments on new build and remedial work applications.
- Build in carefully in accordance with manufacturer's recommendations to ensure a fully watertight installation.
- Reference: e.g. 10001 Intermediate Tray (RH) 225mm long (roof pitches 25°+)

How to Order

- To calculate quantities allow one cavity tray per course on each roof slope. One stopend starter or corner starter is needed per roof slope, and one ridge tray at each apex
- Check roof pitch and select correct length of tray to suit it
- Select the correct handing to suit the direction of each roof slope
- Always state cavity width, roof pitch and coursing height to ensure correct goods are despatched



Everdry Adjustable Stepped Cavity Trays for Brickwork

Stepped cavity tray system for multi cavity options in brick wall construction of 75mm course heights

Calculating Quantities of Stepped Cavity Trays

Stepped cavity trays are used where a pitched roof abuts a cavity wall. To calculate the quantity of trays required to cover a section of roof abutment one of three measurements must be determined, either the vertical height or the sloping or horizontal length of the abutment. If the vertical height is measured, simply divide this distance by the coursing height of the material being used for construction.

E.g. If the vertical height is 1.5m and the wall is standard 75mm brick coursing (NB 75mm = 0.075m) the equation would be $1.5 \div 0.075 = 20$. Therefore 20 No. cavity trays are required per sloping abutment.

If the sloping or horizontal distance has been measured the tables shown opposite should be used to convert the distance (measured in metres) into the quantity of cavity trays. Take care to select the correct table and the appropriate column which relates to the coursing height and the pitch of the abutting roof.

E.g. If the sloping measurement is 2.5m, at a pitch of 30°, with a 75mm brick coursing height the equation would be $2.5 \times 6.7 = 16.75$. This would be rounded up, so 17 No. cavity trays are required.

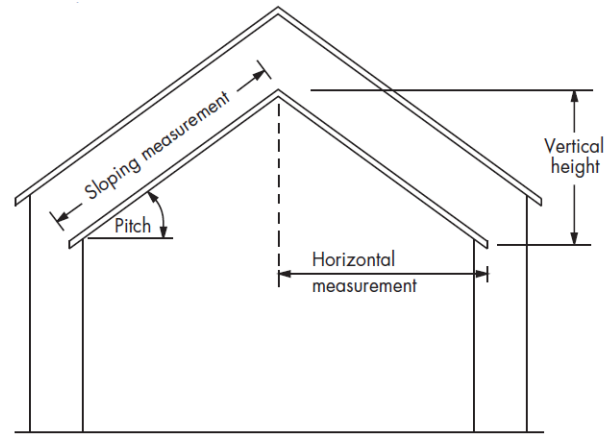
E.g. If the horizontal measurement is 1.5m, at a pitch of 40°, with a 75mm brick coursing height the equation would be $1.5 \times 11.2 = 16.8$. This would be rounded down, so 16 No. cavity trays are required.

Stepped cavity trays sloping measurement

Roof Pitch	Coursing height 75mm brick
10°	2.3
12.5°	2.9
15°	3.5
17.5°	4.0
20°	4.6
22.5°	5.1
25°	5.6
27.5°	6.2
30°	6.7
32.5°	7.2
35°	7.7
37.5°	8.1
40°	8.6
42.5°	9.0
45°	9.4

Stepped cavity trays horizontal measurement

Roof Pitch	Coursing height 75mm brick
10°	2.4
12.5°	3.0
15°	3.6
17.5°	4.2
20°	4.9
22.5°	5.5
25°	6.2
27.5°	7.0
30°	7.7
32.5°	8.5
35°	9.3
37.5°	10.2
40°	11.2
42.5°	12.2
45°	13.3



Free cavity tray specification and scheduling service

Contact Technical on 01405 782 769

Product Codes

75mm brick coursing

Description	Length	Handing	Product Codes To suit clear cavity widths of 50mm - 110mm
Intermediate tray	225mm	RH	10001
Intermediate tray	225mm	LH	10002
Intermediate tray	420mm*	RH	10011
Intermediate tray	420mm*	LH	10012
Stopend starter tray	225mm	RH/LH	10031
Corner starter tray	225mm	RH/LH	10041
Ridge tray	225mm	N/A	10061
Ridge tray	420mm	N/A	10062

For trays featuring the polystyrene strip mortar barrier insert 'P' at the end of the required product code. This may incur additional charge.

N.B Stopend starter, corner starter and ridge trays suit all roof pitches

* For roof pitches 15°-22.5°

525mm long tray available "fixed cavity" for roof pitches 10°-15°

For wider cavity widths contact Timloc Technical



Scan to view the full product page on the Timloc website

Everdry Stepped Cavity Trays for Stonework

Stepped cavity tray system for multi cavity options in stone wall construction of 150mm course heights

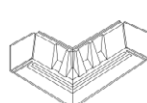
CAVITY TRAYS



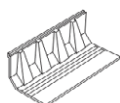
Intermediate tray (LH)



Stopend starter tray (LH/RH)



Corner starter tray (LH/RH)



Ridge tray

Use

- At the abutment of a pitched roof with a cavity wall
- On external walls - not exceeding 150mm thickness - built from natural or reconstituted stone with regular course heights, including mortar of approx. 150mm
- On roof pitches of 7.5 degrees and above
- Clear cavity widths of between 50mm-125mm
- For wider cavity widths contact Timloc Technical

Features and Benefits

- 150mm high back upstand exceeds minimum requirements
- Permanent stopend protects the perpendicular joint and cuts out water backtracking along the stonework
- Angled section between cavity tray base and rear upstand automatically sheds water to the outer leaf
- Cavity tray builds into the outer leaf only to speed up installation and allow both inner and outer leaves to be built independently if required
- Choice of three lengths: 450mm for roof pitches of 25 degrees or above; 625mm for roof pitches of 17.5-22.5 degrees; 1250mm for roof pitches of 7.5-15 degrees
- The system is available on request with pre-applied polystyrene strips. Polystyrene is much easier to rake out than mortar and offers a visual locator of the cavity tray so aiding the installation of post fitted lead work. (This service may incur additional charge)

Quality

- BBA Approved
- Satisfies all NHBC requirements
- Manufactured to BS EN ISO 9001 and BS EN ISO 14001
- Complies with all relevant Building Regulations
- Meets all relevant British Standards

Material and Colour Choice

- All products are vacuum formed in 2.0mm thick medium density polyethylene
- Available in black only

Products in the Range

Intermediate trays

Forms main tray run with one tray on each course of stonework running the full length of the abutting roof slope.

Stopend starter trays

Suits all roof pitches - first component to be installed and fitted at the lowest point on a standard abutment. It collects water gathered by the rest of the system and discharges it from the wall through a weep hole.

Corner starter trays

Suits all roof pitches - has same function as stopend starter tray but is used where the abutting roof comes up to, or beyond, the corner of the main building. Designed to return around the corner of the building to provide complete protection.

Ridge trays

Suits all roof pitches - used where a right hand and left hand roof slope come together at an apex to straddle the top two intermediate trays.



Installation Advice

- Each length of tray is available with a variety of base widths to suit different wall thicknesses and cavity width combinations. Wall thicknesses of either 100mm, 125mm or 150mm can be accommodated as well as cavity widths of 50-74mm, 75-99mm and 100-125mm - make sure you select the correct width for the project in hand
- Weep holes can be formed by simply installing a purpose-made Timloc plastic wall weep unit (product 1143/Invisiweep)
- In areas of severe weather exposure or where particularly porous facing stonework is used, it is strongly recommended that extra weep holes are provided at intermediate points along the run of cavity trays
- Many components come in left or right handed versions. Handing is dictated by the direction of the abutting roof slope - e.g. left handed trays are used on left handed roof slopes. Establish the correct handings or it will be impossible to fit the cavity trays properly
- With pre-formed cavity trays such as Everdry it is not strictly necessary for the cavity tray to span all the way across the cavity. As long as the cavity tray stands back from the rear face of the stone and projects back into the cavity far enough to intercept drips falling from the wall ties, then it will perform effectively.

Bill of Quantity

F30 Accessories/sundry items for brick/block/stone walling

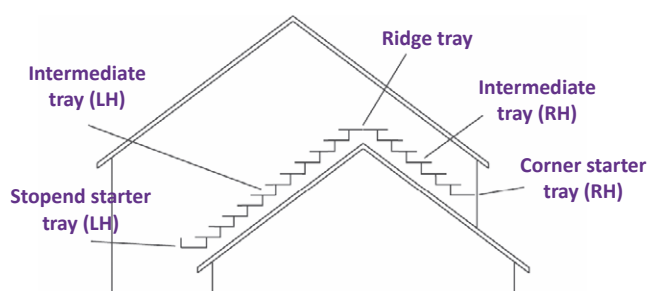
Clause

370 | PREFORMED CAVITY TRAY / ACCESSORIES

- Manufacturer: Timloc Building Products, Timloc House, Ozone Park, Howden, East Yorkshire, DN14 7SD. T: 01405 765567 W: www.timloc.co.uk
- Type(s) and location(s): Cavity tray to be installed into 150mm stonework over stepped/sloping roof abutments on new build and remedial work applications.
- Build in carefully in accordance with manufacturer's recommendations to ensure a fully watertight installation.
- Cavity width: ...
- External wall thickness: ...
- Roof pitch: ...
- Reference: e.g. Intermediate Tray (RH) 450mm long (roof pitches 25°+)

How to Order

- To calculate quantities allow one cavity tray per course on each roof slope. One stopend starter or corner starter is needed per roof slope, and one ridge tray at each apex
- Check roof pitch and select correct length of tray to suit it
- Make sure correct handing is selected to suit the direction of each roof slope
- Always state cavity width, roof pitch, coursing height and wall thickness to ensure correct goods are despatched



Everdry Stepped Cavity Trays for Stonework

Stepped cavity tray system for multi cavity options in stone wall construction of 150mm course heights

Product Codes

150mm stone coursing
100mm external wall thickness (bed)

Description	Length	Product Codes To suit clear cavity widths of:		
		50-74mm	75-99mm	100-125mm
Intermediate tray RH	450mm	7101	7103	7105
Intermediate tray LH	450mm	7102	7104	7106
Intermediate tray RH	625mm	7111	7113	7115
Intermediate tray LH	625mm	7112	7114	7116
Intermediate tray RH	1250mm	7121	7123	7125
Intermediate tray LH	1250mm	7122	7124	7126
Stopend starter RH/LH	450mm	7131	7133	7135
Corner starter tray RH	550mm	7141	7143	7145
Corner starter tray LH	550mm	7142	7144	7146
Ridge tray	450mm	7161	7162	7163

150mm stone coursing
150mm external wall thickness (bed)

Description	Length	Product Codes To suit clear cavity widths of:		
		50-74mm	75-99mm	100-125mm
Intermediate tray RH	450mm	7105	7107	7109
Intermediate tray LH	450mm	7106	7108	7110
Intermediate tray RH	625mm	7115	7117	7119
Intermediate tray LH	625mm	7116	7118	7120
Intermediate tray RH	1250mm	7125	7127	7129
Intermediate tray LH	1250mm	7126	7128	7130
Stopend starter RH/LH	450mm	7135	7137	7139
Corner starter tray RH	550mm	7145	7147	7149
Corner starter tray LH	550mm	7146	7148	7150
Ridge tray	450mm	7163	7164	7165

150mm stone coursing
125mm external wall thickness (bed)

Description	Length	Product Codes To suit clear cavity widths of:		
		50-74mm	75-99mm	100-125mm
Intermediate tray RH	450mm	7103	7105	7107
Intermediate tray LH	450mm	7104	7106	7108
Intermediate tray RH	625mm	7113	7115	7117
Intermediate tray LH	625mm	7114	7116	7118
Intermediate tray RH	1250mm	7123	7125	7127
Intermediate tray LH	1250mm	7124	7126	7128
Stopend starter RH/LH	450mm	7133	7135	7137
Corner starter tray RH	550mm	7143	7145	7147
Corner starter tray LH	550mm	7144	7146	7148
Ridge tray	450mm	7162	7163	7164

For trays featuring the polystyrene strip mortar barrier insert 'P' at the end of the required product code. This may incur additional charge.

For wider cavity widths contact Timloc Technical



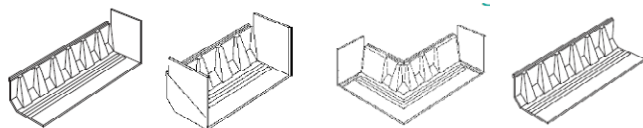
Scan to view the full product page on the Timloc website

Free cavity tray specification and scheduling service

Contact Technical on 01405 782 769

Everdry Stepped Cavity Trays for Blockwork/Stonework

Stepped cavity tray system for blockwork/stonework construction of 225mm course heights



Intermediate tray (LH)

Stopend starter tray (LH/RH)

Corner starter tray (RH)

Ridge tray

Use

- At the abutment of a pitched roof with a cavity wall
- On external walls - not exceeding 150mm thickness - built from blockwork or stone with regular course heights, including mortar of approx. 225mm
- On roof pitches of 12.5 degrees and above
- Clear cavity widths of between 50mm-125mm
- For wider cavity widths contact Timloc Technical

Features and Benefits

- 150mm high back upstand exceeds minimum requirements
- Permanent stopend protects the perpendicular joint and cuts out water backtracking along the blockwork/stonework
- Angled section between cavity tray base and rear upstand automatically sheds water to the outer leaf Cavity tray builds into the outer leaf only to speed up installation and allow both inner and outer leaves to be built independently if required
- Choice of two lengths: 625mm for roof pitches of 25 degrees or above; 1250mm for roof pitches of 12.5-22.5 degrees
- The system is available on request with pre-applied polystyrene strips. Polystyrene is much easier to rake out than mortar and offers a visual locator of the cavity tray so aiding the installation of post fitted lead work. (This service may incur additional charge)

Quality

- BBA Approved
- Satisfies all NHBC requirements
- Manufactured to BS EN ISO 9001 and BS EN ISO 14001
- Complies with all relevant Building Regulations
- Meets all relevant British Standards

Material and Colour Choice

- All products are vacuum formed in 2.0mm thick medium density polyethylene

Products in the Range

Intermediate trays

Forms main tray run with one tray on each course of blockwork/stonework running the full length of the abutting roof slope.

Stopend starter trays

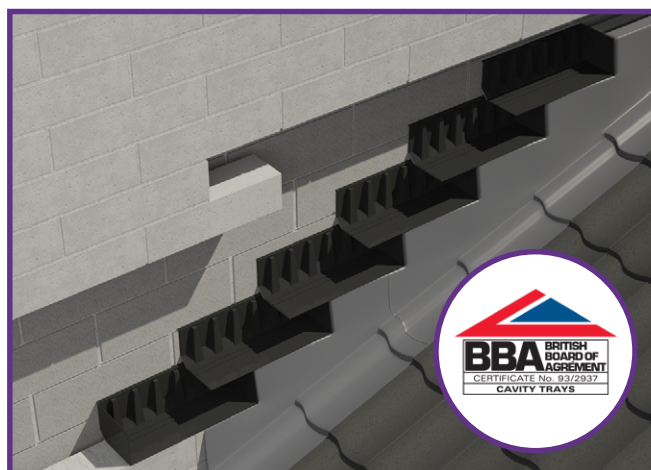
Suits all roof pitches - first component to be installed and fitted at the lowest point on a standard abutment. It collects water gathered by the rest of the system and discharges it from the wall through a weep hole.

Corner starter trays

Suits all roof pitches - has same function as stopend starter tray but is used where the abutting roof comes up to, or beyond, the corner of the main building. Designed to return around the corner of the building to provide complete protection.

Ridge trays

Suits all roof pitches - used where a right hand and left hand roof slope come together at an apex to straddle the top two intermediate trays.



Installation Advice

- Each length of tray is available with a variety of base widths to suit different wall thicknesses and cavity width combinations. Wall thicknesses of either 100mm, 125mm or 150mm can be accommodated as well as cavity widths of 50-74mm, 75-99mm and 100-125mm - make sure you select the correct width for the project in hand
- Weep holes can be formed by simply installing a purpose-made Timloc plastic wall weep unit (product 1143/Invisiweep)
- In areas of severe weather exposure or where particularly porous facing stonework is used, it is strongly recommended that extra weep holes are provided at intermediate points along the run of cavity trays
- Many components come in left or right handed versions. Handing is dictated by the direction of the abutting roof slope - e.g. left handed trays are used on left handed roof slopes. Establish the correct handings or it will be impossible to fit the cavity trays properly
- With pre-formed cavity trays such as Everdry it is not strictly necessary for the cavity tray to span all the way across the cavity. As long as the cavity tray stands back from the rear face of the stone and projects back into the cavity far enough to intercept drips falling from the wall ties, then it will perform effectively.

Bill of Quantity

F30 Accessories/sundry items for brick/block/stone walling

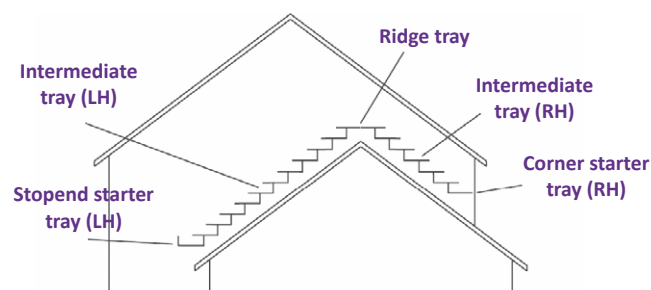
Clause

370 | PREFORMED CAVITY TRAY / ACCESSORIES

- Manufacturer: Timloc Building Products, Timloc House, Ozone Park, Howden, East Yorkshire, DN14 7SD. T: 01405 765567 W: www.timloc.co.uk
- Type(s) and location(s): Cavity tray to be installed into 225mm stonework over stepped/sloping roof abutments on new build and remedial work applications.
- Build in carefully in accordance with manufacturer's recommendations to ensure a fully watertight installation.
- Cavity width: ...
- External wall thickness: ...
- Roof pitch: ...
- Reference: e.g. Intermediate Tray (RH) 625mm long (roof pitches 25°+)

How to Order

- To calculate quantities allow one cavity tray per course on each roof slope. One stopend starter or corner starter is needed per roof slope, and one ridge tray at each apex
- Check roof pitch and select correct length of tray to suit it
- Make sure correct handing is selected to suit the direction of each roof slope
- Always state cavity width, roof pitch, coursing height and wall thickness to ensure correct goods are despatched



Everdry Stepped Cavity Trays for Blockwork/Stonework

Stepped cavity tray system for blockwork/stonework construction of 225mm course heights

Product Codes

225mm block/stone coursing
100mm external wall thickness (bed)

Description	Length	Product Codes To suit clear cavity widths of:		
		50-74mm	75-99mm	100-125mm
Intermediate tray RH	625mm	7201	7203	7205
Intermediate tray LH	625mm	7202	7204	7206
Intermediate tray RH	1250mm	7211	7213	7215
Intermediate tray LH	1250mm	7212	7214	7216
Stopend starter RH/LH	450mm	7231	7233	7235
Corner starter tray RH	550mm	7241	7243	7245
Corner starter tray LH	550mm	7242	7244	7246
Ridge tray	625mm	7261	7262	7263

225mm block/stone coursing
150mm external wall thickness (bed)

Description	Length	Product Codes To suit clear cavity widths of:		
		50-74mm	75-99mm	100-125mm
Intermediate tray RH	625mm	7205	7207	7209
Intermediate tray LH	625mm	7206	7208	7210
Intermediate tray RH	1250mm	7215	7217	7219
Intermediate tray LH	1250mm	7216	7218	7220
Stopend starter RH/LH	450mm	7235	7237	7239
Corner starter tray RH	550mm	7245	7247	7249
Corner starter tray LH	550mm	7246	7248	7250
Ridge tray	625mm	7263	7264	7265

225mm block/stone coursing
125mm external wall thickness (bed)

Description	Length	Product Codes To suit clear cavity widths of:		
		50-74mm	75-99mm	100-125mm
Intermediate tray RH	625mm	7203	7205	7207
Intermediate tray LH	625mm	7204	7206	7208
Intermediate tray RH	1250mm	7213	7215	7217
Intermediate tray LH	1250mm	7214	7216	7218
Stopend starter RH/LH	450mm	7233	7235	7237
Corner starter tray RH	550mm	7243	7245	7247
Corner starter tray LH	550mm	7244	7246	7248
Ridge tray	625mm	7262	7263	7264

For trays featuring the polystyrene strip mortar barrier insert 'P' at the end of the required product code. This may incur additional charge.

For wider cavity widths contact Timloc Technical



Scan to view the full product page on the Timloc website

Free cavity tray specification and scheduling service
Contact Technical on 01405 782 769

Everdry Stepped Cavity Trays for Brickwork - Lead Attached

Stepped leaded cavity tray system for multi cavity options in brickwall constructions of 75mm course heights



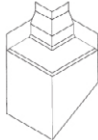
Intermediate tray short lead (LH)



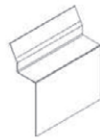
Intermediate tray long lead (LH)



Stopend starter tray short lead (LH)



Corner starter tray long lead (LH)



Ridge tray



Use

- At the abutment of a pitched roof with a cavity wall
- On external walls - not exceeding 120mm thickness - built from standard brickwork or similar sized components with regular course heights, including mortar of approx. 75mm
- On roof pitches of 15 degrees and above
- Clear cavity widths of between 50mm-110mm
- For wider cavity widths contact Timloc Technical

Features and Benefits

- Supplied with factory fitted lead flashing ready cut to suit the pitch of the roof and type of roof covering
- High back upstand
- Adjustable upstand to cover 50mm-110mm clear cavities
- Roof pitch marks on tray upstand to give installation guidance
- Cavity tray builds into outer leaf only to speed up installation and allowing both inner and outer leaves to be built independently

Quality

- BBA Approved
- Satisfies all NHBC requirements
- Manufactured to BS EN ISO 9001 and BS EN ISO 14001
- Complies with all relevant Building Regulations
- Meets all relevant British Standards

Material and Colour Choice

- Flashings are Code Blue milled lead as standard as defined by BS EN ISO 12588 : 1999 (formally known as Code 4)
- All components in the range are injection moulded in 2mm polypropylene for added durability, toughness and quality
- Available in black only

Products in the Range

Intermediate trays

Suits all cavity options - forms main tray run with one tray on each course of brickwork running the full length of the abutting roof slope.

Stopend starters

First component to be installed and fitted at the lowest point on a standard abutment. It collects water gathered by the rest of the system and discharges it from the wall through a weep unit.

Corner starter trays

Has same function as stopend starter tray but is used where the abutting roof comes up to, or beyond, the corner of the main building. Designed to return around the corner of the building to provide complete protection.

Ridge trays

Used where a right hand and left hand roof slope come together at an apex to straddle the top two intermediate tray.

Installation Advice

- The core tray will suit clear cavity widths of 50-110mm
- Weep holes in starter and corner starter trays can be formed simply by installing purpose made Timloc plastic wall weep units (product 1143/ Invisiweep)
- In areas of severe weather exposure, long continuous run of cavity trays and/or where particularly porous facing brickwork is used, we strongly recommend that extra weep holes are used at intermediate points along the run of cavity trays. Heavier code lead may also need to be specified with flashings fixed and sealed where they overlap
- Many components come in left or right handed versions. Handing is dictated by the direction of the abutting roof slope
- With pre-formed cavity trays such as Everdry it is not strictly necessary for the cavity tray to span all the way across the cavity. As long as the cavity tray stands back from the rear face of the stone and projects back into the cavity far enough to intercept drips falling from the wall ties, then it will perform effectively.

Contact Timloc Technical department for further installation guidance.

How to Order

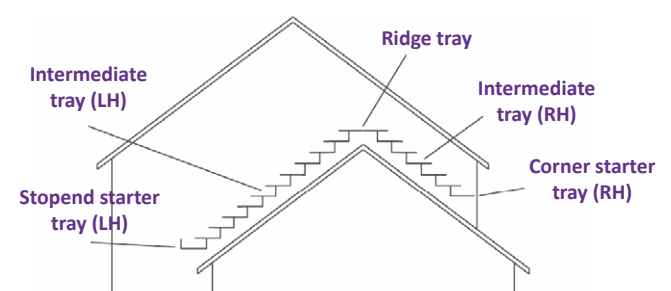
- To calculate quantities allow one cavity tray per course on each roof slope. One stopend starter or corner starter is needed per roof slope, and one ridge tray at each apex
- Check roof pitch and select correct length of tray to suit it
- Make sure correct handing is selected to suit the direction of each roof slope
- Always state cavity width, roof pitch and coursing height to ensure correct goods are despatched

Bill of Quantity

F30 Accessories/sundry items for brick/block/stone walling
Clause

370 | PREFORMED CAVITY TRAY / ACCESSORIES

- Manufacturer: Timloc Building Products, Timloc House, Ozone Park, Howden, East Yorkshire, DN14 7SD. T: 01405 765567 W: www.timloc.co.uk
- Type(s) and location(s): Cavity tray with attached lead to be installed into brickwork over stepped/sloping roof abutments on new build and remedial work applications.
- Build in carefully in accordance with manufacturer's recommendations to ensure a fully watertight installation.
- Reference: e.g. 20001 Intermediate Tray (RH)
- Cavity width: 50mm – 110mm
- Roof pitches: 15° - 60° (please stipulate)
- Lead attachment: e.g. Code Blue short or long (please stipulate)
- (short lead – flat tiles/slates) (long leads – profiled roof tile)



Everdry Stepped Cavity Trays for Brickwork - Lead Attached

Stepped leaded cavity tray system for multi cavity options in brickwall constructions of 75mm course heights

Calculating Quantities of Stepped Cavity Trays

- Stepped cavity trays are used where a pitched roof abuts a cavity wall. To calculate the quantity of trays required to cover a section of roof abutment one of three measurements must be determined, either the vertical height or the sloping or horizontal length of the abutment. If the vertical height is measured, simply divide this distance by the coursing height of the material being used for construction. E.g. If the vertical height is 1.5m and the wall is standard 75mm brick coursing (NB 75mm = 0.075m) the equation would be $1.5 \div 0.075 = 20$. Therefore 20 No. cavity trays are required per sloping abutment.
- If the sloping or horizontal distance has been measured the tables shown below should be used to convert the distance (measured in metres) into the quantity of cavity trays. Take care to select the correct table and the appropriate column which relates to the coursing height and the pitch of the abutting roof. E.g. If the sloping measurement is 2.5m, at a pitch of 30°, with a 75mm brick coursing height the equation would be $2.5 \times 6.7 = 16.75$. This would be rounded up, so 17 No. cavity trays are required. E.g. If the horizontal measurement is 1.5m, at a pitch of 40°, with a 75mm brick coursing height the equation would be $1.5 \times 11.2 = 16.8$. This would be rounded down, so 16 No. cavity trays are required.

Stepped cavity trays sloping measurement

Roof Pitch	Coursing height 75mm brick
10°	2.3
12.5°	2.9
15°	3.5
17.5°	4.0
20°	4.6
22.5°	5.1
25°	5.6
27.5°	6.2
30°	6.7
32.5°	7.2
35°	7.7
37.5°	8.1
40°	8.6
42.5°	9.0
45°	9.4

Stepped cavity trays horizontal measurement

Roof Pitch	Coursing height 75mm brick
10°	2.4
12.5°	3.0
15°	3.6
17.5°	4.2
20°	4.9
22.5°	5.5
25°	6.2
27.5°	7.0
30°	7.7
32.5°	8.5
35°	9.3
37.5°	10.2
40°	11.2
42.5°	12.2
45°	13.3

Product Codes

75mm brickwork coursing

Description	Length	Handing	Product Codes
			To suit clear cavity widths of: 50-110mm
Intermediate tray	Varies	RH	20001
Intermediate tray	Varies	LH	20002
Stopend starter tray	225mm	RH/LH	20031/32
Corner starter tray	225mm	RH/LH	20041/42
Ridge tray	225mm	N/A	20061
Ridge tray	420mm	N/A	20062

For wider cavity widths contact Timloc Technical

When ordering, please state roof pitch and whether long or short leads are required.



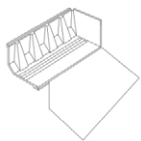
Scan to view the full product page on the Timloc website

Free cavity tray specification and scheduling service

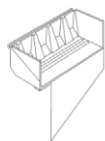
Contact Technical on 01405 782 769

Everdry Stepped Cavity Trays for Stonework - Lead Attached

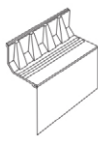
Stepped leaded cavity tray system for stonework constructions of 150mm course heights



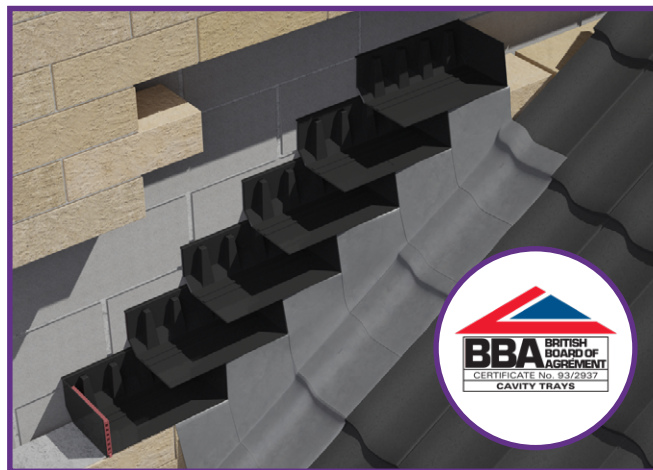
Intermediate tray
long lead (LH)



Stopend starter tray
short lead (LH)



Ridge tray



Use

- At the abutment of a pitched roof with a cavity wall
- On external walls - not exceeding 150mm thickness - built from natural or reconstituted stone with regular course heights, including mortar of approx. 150mm
- On roof pitches of 15 degrees and above
- Clear cavity widths of between 50mm-125mm
- For wider cavity widths contact Timloc Technical

Features and Benefits

- Supplied with factory fitted lead flashing ready cut to suit the pitch of the roof and type of roof covering
- 150mm high back upstand exceeds minimum requirements
- Permanent stopend protects the perpendicular joint and cuts out water backtracking along the stonework
- Angled section between cavity tray base and rear upstand automatically sheds water to the outer leaf
- Cavity tray builds into the outer leaf only to speed up installation and allow both inner and outer leaves to be built independently if required

Quality

- BBA Approved
- Satisfies all NHBC requirements
- Manufactured to BS EN ISO 9001 and BS EN ISO 14001
- Complies with all relevant Building Regulations
- Meets all relevant British Standards

Material and Colour Choice

- Flashings are Code Blue milled lead as standard as defined by BS EN ISO 12588 : 1999 (formally known as Code 4)
- All products are vacuum formed in 2.0mm thick rigid polyethylene
- Available in black only

Products in the Range

Intermediate trays

Forms main tray run with one tray on each course of stonework running the full length of the abutting roof slope.

Stopend starter tray

Suits all roof pitches - first component to be installed and fitted at the lowest point on a standard abutment. It collects water gathered by the rest of the system and discharges it from the wall through a weep hole.

Corner starter tray

Suits all roof pitches - has same function as stopend starter tray but is used where the abutting roof comes up to, or beyond, the corner of the main building. Designed to return around the corner of the building to provide complete protection. Corner starter trays are not supplied with factory fitted lead flashings due to the size and weight of lead flashing that would be required. Flashing in this area should be dealt with separately in the traditional way.

Ridge trays

Suits all roof pitches - used where a right hand and left hand roof slope come together at an apex to straddle the top two intermediate trays.

Installation Advice

- Each length of tray is available with a variety of base widths to suit different wall thicknesses and cavity width combinations. Wall thicknesses of either 100mm, 125mm or 150mm can be accommodated as well as cavity widths of 50-74mm, 75-99mm and 100-125mm - make sure you select the correct width for the project in hand
- Weep holes can be formed by simply installing a purpose-made Timloc plastic wall weep unit (product 1143/Invisweep)
- In areas of severe weather exposure or where particularly porous facing stonework is used, it is strongly recommended that extra weep holes are provided at intermediate points along the run of cavity trays. A heavier code of lead may also need to be specified with flashings fixed and sealed where they overlap
- Many components come in left or right handed versions. Handing is dictated by the direction of the abutting roof slope - e.g. left handed trays are used on left handed roof slopes. Establish the correct handings or it will be impossible to fit the cavity trays properly
- With pre-formed cavity trays such as Everdry it is not strictly necessary for the cavity tray to span all the way across the cavity. As long as the cavity tray stands back from the rear face of the stone and projects back into the cavity far enough to intercept drips falling from the wall ties, then it will perform effectively

Contact Timloc Technical department for installation guidance.

How to Order

- To calculate quantities allow one cavity tray per course on each roof slope. One stopend starter or corner starter is needed per roof slope, and one ridge tray at each apex
- Check roof pitch and type of tile or slate and state clearly on your order
- Make sure correct handing is selected to suit the direction of each roof slope
- Always state cavity width, roof pitch, coursing height and wall thickness to ensure correct goods are despatched
- State whether long or short leads are required. Long leads are used with single lap concrete or clay roof tiles and dress over the top of the roof finish. Short leads are used with slates or double lap tiles, e.g. Rosemary type, and dress over the upstand of the soakers

Bill of Quantity

F30 Accessories/sundry items for brick/block/stone walling
Clause

370 PREFORMED CAVITY TRAY / ACCESSORIES

- Manufacturer: Timloc Building Products, Timloc House, Ozone Park, Howden, East Yorkshire, DN14 7SD. T: 01405 765567 W: www.timloc.co.uk
- Type(s) and location(s): Cavity tray to be installed into 150mm stonework over stepped/sloping roof abutments on new build and remedial work applications.
- Build in carefully in accordance with manufacturer's recommendations to ensure a fully watertight installation.
- Cavity width: ...
- External wall thickness: ...
- Roof pitches: 15° - 60° (please stipulate)
- Lead attachment: Code Blue short or long (please stipulate)
- (short lead - flat tiles/slates)
- (long leads - profiled roof tile)

Everdry Stepped Cavity Trays for Stonework - Lead Attached

Stepped leaded cavity tray system for stonework constructions of 150mm course heights

Product Codes

150mm stone coursing
100mm external wall thickness (bed)

Description	Length	Product Codes		
		To suit clear cavity widths of:		
		50-74mm	75-99mm	100-125mm
Intermediate tray RH	Varies	8101	8103	8105
Intermediate tray LH	Varies	8102	8104	8106
Stopend starter tray RH	450mm	8131	8133	8135
Stopend starter tray LH	450mm	8132	8134	8136
Corner starter tray RH*	550mm	7141	7143	7145
Corner starter tray LH*	550mm	7142	7144	7146
Ridge tray	450mm	8161	8162	8163

150mm stone coursing
150mm external wall thickness (bed)

Description	Length	Product Codes		
		To suit clear cavity widths of:		
		50-74mm	75-99mm	100-125mm
Intermediate tray RH	Varies	8105	8107	8109
Intermediate tray LH	Varies	8106	8108	8110
Stopend starter tray RH	450mm	8135	8137	8139
Stopend starter tray LH	450mm	8136	8138	8140
Corner starter tray RH*	550mm	7145	7147	7149
Corner starter tray LH*	550mm	7146	7148	7150
Ridge tray	450mm	8163	8164	8165

150mm stone coursing
125mm external wall thickness (bed)

Description	Length	Product Codes		
		To suit clear cavity widths of:		
		50-74mm	75-99mm	100-125mm
Intermediate tray RH	Varies	8103	8105	8107
Intermediate tray LH	Varies	8104	8106	8108
Stopend starter tray RH	450mm	8133	8135	8137
Stopend starter tray LH	450mm	8134	8136	8138
Corner starter tray RH*	550mm	7143	7145	7147
Corner starter tray LH*	550mm	7144	7146	7148
Ridge tray	450mm	8162	8163	8164

When ordering state roof pitch and whether long or short leads are required.

* Not supplied with factory fitted lead flashings.

For wider cavity widths contact Timloc Technical



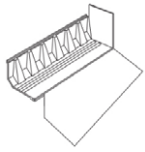
Scan to view the full product page on the Timloc website

Free cavity tray specification and scheduling service

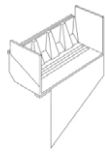
Contact Technical on 01405 782 769

Everdry Stepped Cavity Trays for Blockwork - Lead Attached

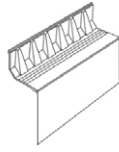
Stepped leaded cavity tray system for blockwork/stonework constructions of 225mm course heights



Intermediate tray
long lead (LH)



Stopend starter tray
short lead (LH)



Ridge tray

Use

- At the abutment of a pitched roof with a cavity wall
- On external walls - not exceeding 150mm thickness - built from blockwork or stone with regular course heights, including mortar of approx. 225mm
- On roof pitches of 12.5 degrees and above
- Clear cavity widths of between 50mm-125mm
- For wider cavity widths contact Timloc Technical

Features and Benefits

- Supplied with factory fitted lead flashing cut to suit the pitch of the roof and type of roof covering
- 150mm high back upstand exceeds minimum requirements
- Permanent stopend protects the perpendicular joint and cuts out water backtracking along the blockwork/stonework
- Angled section between cavity tray base and rear upstand automatically sheds water to the outer leaf
- Cavity tray builds into the outer leaf only to speed up installation and allow both inner and outer leaves to be built independently if required

Quality

- BBA Approved
- Satisfies all NHBC requirements
- Manufactured to BS EN ISO 9001 and BS EN ISO 14001
- Complies with all relevant Building Regulations
- Meets all relevant British Standards

Material and Colour Choice

- Flashings are Code Blue milled lead as standard as defined by BS EN 12588 : 1999 (formally known as Code 4)
- All products are vacuum formed in 2.0mm thick rigid polyethylene
- Available in black only

Products in the Range

Intermediate trays

Forms main tray run with one tray on each course of blockwork/stonework running the full length of the abutting roof slope.

Stopend starter tray

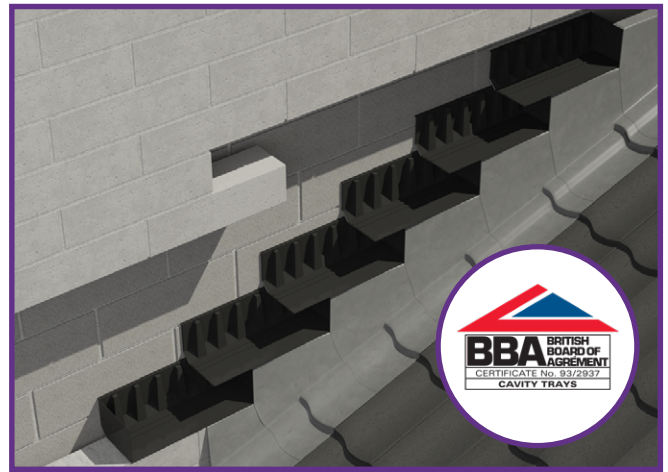
Suits all roof pitches - first component to be installed and fitted at the lowest point on a standard abutment. It collects water gathered by the rest of the system and discharges it from the wall through a weep hole.

Corner starter tray

Suits all roof pitches - has same function as stopend starter tray but is used where the abutting roof comes up to, or beyond, the corner of the main building. Designed to return around the corner of the building to provide complete protection. Corner starter trays are not supplied with factory fitted lead flashings due to the size and weight of lead flashing that would be required. Flashing in this area should be dealt with separately in the traditional way.

Ridge trays

Suits all roof pitches - used where a right hand and left hand roof slope come together at an apex to straddle the top two intermediate trays.



Installation Advice

- Each length of tray is available with a variety of base widths to suit different wall thicknesses and cavity width combinations. Wall thicknesses of either 100mm, 125mm or 150mm can be accommodated as well as cavity widths of 50-74mm, 75-99mm and 100-125mm - make sure you select the correct width for the project in hand
- Weep holes can be formed by simply installing a purpose-made Timloc plastic wall weep unit (product 1143/Invisiweep)
- In areas of severe weather exposure or where particularly porous facing blockwork/stonework is used, it is strongly recommended that extra weep holes are provided at intermediate points along the run of cavity trays. A heavier code of lead may also need to be specified with flashings fixed and sealed where they overlap
- Many components come in left or right handed versions. Handing is dictated by the direction of the abutting roof slope - e.g. left handed trays are used on left handed roof slopes. Establish the correct handings or it will be impossible to fit the cavity trays properly
- With pre-formed cavity trays such as Everdry it is not strictly necessary for the cavity tray to span all the way across the cavity. As long as the cavity tray stands back from the rear face of the block and projects back into the cavity far enough to intercept

Contact Timloc Technical department for installation guidance.

How to Order

- To calculate quantities allow one cavity tray per course on each roof slope. One stopend starter or corner starter is needed per roof slope, and one ridge tray at each apex
- Check roof pitch and type of tile or slate and state clearly on your order
- Make sure correct handing is selected to suit the direction of each roof slope
- Always state cavity width, roof pitch, coursing height and wall thickness to ensure correct goods are despatched
- State whether long or short leads are required. Long leads are used with single lap concrete or clay roof tiles and dress over the top of the roof finish. Short leads are used with slates or double lap tiles, e.g. Rosemary type, and dress over the upstand of the soakers

Bill of Quantity

F30 Accessories/sundry items for brick/block/stone walling
Clause

370 | PREFORMED CAVITY TRAY / ACCESSORIES

- Manufacturer: Timloc Building Products, Timloc House, Ozone Park, Howden, East Yorkshire, DN14 7SD. T: 01405 765567 W: www.timloc.co.uk
- Type(s) and location(s): Cavity tray to be installed into 225mm blockwork over stepped/sloping roof abutments on new build and remedial work applications.
- Build in carefully in accordance with manufacturer's recommendations to ensure a fully watertight installation.
- Reference: e.g. Intermediate Tray (RH)
- Cavity width: ...
- External wall thickness: ...
- Roof pitches: 15° - 60° (please stipulate)
- Lead attachment: Code Blue short or long (please stipulate)
- (short lead – flat tiles/slates)
- (long leads – profiled roof tile)

Everdry Stepped Cavity Trays for Blockwork - Lead Attached

Stepped leaded cavity tray system for blockwork/stonework constructions of 225mm course heights

Product Codes

225mm block/stone coursing
100mm external wall thickness (bed)

Description	Length	Product Codes		
		To suit clear cavity widths of:		
		50-74mm	75-99mm	100-125mm
Intermediate tray RH	Varies	8201	8203	8205
Intermediate tray LH	Varies	8202	8204	8206
Stopend starter tray RH	450mm	8231	8233	8235
Stopend starter tray LH	450mm	8232	8234	8236
Corner starter tray RH*	550mm	7241	7243	7245
Corner starter tray LH*	550mm	7242	7244	7246
Ridge tray	450mm	8261	8262	8263

225mm block/stone coursing
150mm external wall thickness (bed)

Description	Length	Product Codes		
		To suit clear cavity widths of:		
		50-74mm	75-99mm	100-125mm
Intermediate tray RH	Varies	8205	8207	8209
Intermediate tray LH	Varies	8206	8208	8210
Stopend starter tray RH	450mm	8235	8237	8239
Stopend starter tray LH	450mm	8236	8238	8240
Corner starter tray RH*	550mm	7245	7247	7249
Corner starter tray LH*	550mm	7246	7248	7250
Ridge tray	450mm	8263	8264	8265

225mm block/stone coursing
125mm external wall thickness (bed)

Description	Length	Product Codes		
		To suit clear cavity widths of:		
		50-74mm	75-99mm	100-125mm
Intermediate tray RH	Varies	8203	8205	8207
Intermediate tray LH	Varies	8204	8206	8208
Stopend starter tray RH	450mm	8233	8235	8237
Stopend starter tray LH	450mm	8234	8236	8238
Corner starter tray RH*	550mm	7243	7245	7247
Corner starter tray LH*	550mm	7244	7246	7248
Ridge tray	450mm	8262	8263	8264

When ordering state roof pitch and whether long or short leads are required.

* Not supplied with factory fitted lead flashings.

For wider cavity widths contact Timloc Technical



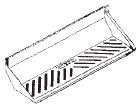
Scan to view the full product page on the Timloc website

Free cavity tray specification and scheduling service

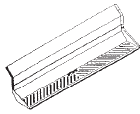
Contact Technical on 01405 782 769

Inter-loc Horizontal Cavity Trays

Preformed horizontal cavity tray system for new build and existing walls



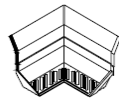
Existing build horizontal tray
IL2/E



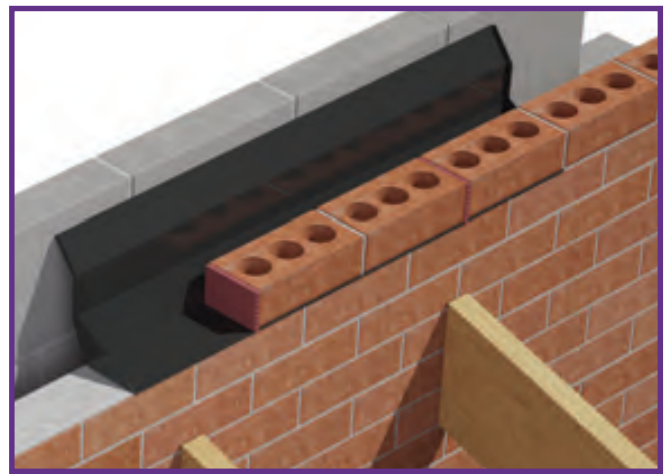
New build horizontal tray
IL4



New build external corner
EXT90



New build internal corner
INT90



Use

- At the abutment of a flat roof with a cavity wall
- At the abutment of a lean-to or mono pitch roof with a cavity wall
- Over concrete ring beams
- Over airbricks, cavity liners, ducts, meter boxes, etc.
- On external walls - not exceeding 102.5mm in thickness - built from standard brickwork, blockwork or stone
- Clear cavity widths of between 50mm-125mm

Features and Benefits

- Fits all clear cavity sizes up to 125mm
- Suitable for brick, block and stone wall construction (cutting of masonry may be required)
- 150mm high back upstand exceeds minimum requirements of NHBC
- Angled section between cavity
- Interlocking mechanism for joining tray lengths to eliminate tray jointing
- Built to brick bonding lengths for ease of use
- Angled section between cavity tray base and rear upstand automatically sheds water to the outer leaf
- Built independent to the inner leaf will enable inner and outer leaves to be built independently, if required
- Available in two lengths: 4 brick for general use and 2 brick for reducing waste when making up a run of cavity tray to the required length
- The system is available upon request with pre-applied polystyrene strips. Polystyrene is much easier to rake out than mortar and offers a visual locator of the cavity tray so aiding the installation of post fitted lead work. This may incur additional charge.

Quality

- Satisfies all NHBC requirements
- Manufactured to BS EN ISO 9001 and BS EN ISO 14001
- Complies with all relevant Building Regulations
- Meets all relevant British Standards

Material and Colour Choice

- Horizontal Inter-loc units are injection moulded in 2mm polypropylene
- Accessories are vacuum formed in 2mm medium density polyethylene
- Available in black only

Products in the Range

Horizontal Inter-loc cavity trays

The main cavity tray component. Sections join together by means of a lapped interlocking joint, to form the main cavity tray run. Water is gathered by the cavity tray and is discharged from the wall through a series of weep holes - one weep hole per Inter-loc tray is required (1143 or Invisiweep).

Corner units

Allows the integrity of the main cavity tray run to be maintained when it is necessary to turn a corner on a building. Available in either external or internal format.

Stopends

Fitted at the start and finish of the cavity tray run to seal off the open ends and prevent water running back into the cavity.

Installation Advice

- Each component is available to suit cavity widths of either 50-125mm
- Weep holes must be provided in every cavity tray to comply with Building Regulation requirements. These can be formed by installing a purpose made Timloc plastic wall weep unit (1143 or Invisiweep)
- Each Inter-loc cavity tray fits to the next by means of a lapped interlocking joint, as work proceeds while working from right to left
- With rigid pre-formed cavity trays such as the Inter-loc system it is not necessary for the cavity tray to span all the way across the cavity. As long as the cavity tray stands back from the rear face of the external wall and projects back into the cavity far enough to intercept drips falling from the wall ties, then it will perform effectively

Contact Timloc Technical department for installation guidance.

How to Order

- To calculate quantities divide the overall length of the cavity tray run by .225 (representing one brick and joint) to give number of bricks required then divide by 2 for IL2 or 4 for IL4 to give tray quantity. Always round up to the next tray because excess length can be cut away
- Please use stopends if the cavity tray has to be cut down to suit the project
- Stopends will not be required when the cavity tray run is built within the body of the building i.e. bay windows. For this application the integrated stopend can be built into the next available joint projecting past the abutting roof
- Contact our Technical department for pricing and assistance

Bill of Quantity | New Build

F30 Accessories/sundry items for brick/block/stone walling
Clause

370 | PREFORMED CAVITY TRAY / ACCESSORIES

- Manufacturer: Timloc Building Products, Timloc House, Ozone Park, Howden, East Yorkshire, DN14 7SD. T: 01405 765567 W: www.timloc.co.uk
- Type(s) and location(s): Cavity tray supplied to be installed over horizontal abutments on new build applications, ring beam systems, airbricks, cavity liners, meter boxes, ducts etc.
- Build in carefully in accordance with manufacturer's recommendations to ensure a fully watertight installation.
- Reference: e.g. Inter-loc 4 Horizontal Tray (4 – Brick Long)
- Optional Accessories: e.g. Inter-loc Internal Corner Tray

Bill of Quantity | Existing

F30 Accessories/sundry items for brick/block/stone walling
Clause

370 | PREFORMED CAVITY TRAY / ACCESSORIES

- Manufacturer: Timloc Building Products, Timloc House, Ozone Park, Howden, East Yorkshire, DN14 7SD. T: 01405 765567 W: www.timloc.co.uk
- Type(s) and location(s): Cavity tray supplied to be installed over horizontal abutments on new build applications, ring beam systems, airbricks, cavity liners, meter boxes, ducts etc.
- Build in accordance with manufacturer's recommendations to ensure a fully watertight installation.
- Reference: e.g. Inter-loc 2 (E) Horizontal Tray (2 – Brick Long)
- Optional Accessories: e.g. EXT90 (E) External Corner 90 Degree

Inter-loc Horizontal Cavity Trays

Preformed horizontal cavity tray system for new build and existing walls

Product Codes | New Build

Description	Effective Length	Product Code
Inter-loc horizontal tray	4 brick/900mm	IL4
Inter-loc horizontal tray	2 brick/450mm	IL2
External 90° corner	1 brick/220mm	EXT90
Internal 90° corner	1 brick/220mm	INT90
External 135° corner	330mm	EXT135
Internal 135° corner	150mm	INT135
Stopend RH		SERH
Stopend LH		SELH

For trays featuring the polystyrene strip mortar barrier insert 'P' at the end of the required product code. This may incur additional charge.

For wider cavity widths contact Timloc Technical

Product Codes | Existing

Description	Effective Length	Product Code
Inter-loc horizontal tray	2 brick/450mm	IL2/E
External 90° corner	1 brick/220mm	EXT90/E
Internal 90° corner	1 brick/220mm	INT90/E
External 135° corner	330mm	EXT135/E
Internal 135° corner	150mm	INT135/E
Stopend RH		SERH
Stopend LH		SELH



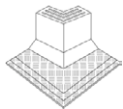
Scan to view the full product page
on the Timloc website

System 2000 Horizontal Cavity Trays

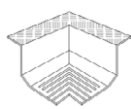
Horizontal cavity tray system for all types of brick, block and stone new build constructions



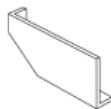
Horizontal cavity tray



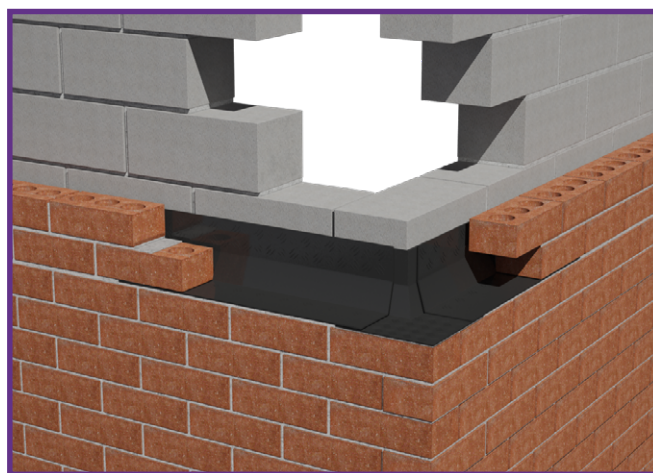
External corner



Internal corner



Stopend (LH)



Use

- At the abutment of a flat roof with a cavity wall
- At the abutment of a lean-to or mono pitch roof with a cavity wall
- Over concrete ring beams
- Over airbricks, cavity liners, ducts, meter boxes, etc.
- Clear cavity widths of between 50mm-150mm
- For wider cavity widths contact Timloc Technical

Features and Benefits

- 150mm high back upstand exceeds minimum requirements
- Low profile lapped joint between sections allows any length of brick, block or stone to be used without difficulty
- Angled section between cavity tray base and rear upstand automatically sheds water to the outer leaf
- Cavity tray builds into the outer leaf only to speed up installation to allow both inner and outer leaves to be built independently if required
- Choice of two lengths: 880mm for general use; 460mm to reduce waste when making up a run of cavity tray to the required length
- System available on request with pre-applied polystyrene strips.
- Polystyrene offers a visual locator of the cavity tray so aiding the installation of post fitted lead work. (May incur additional charge)

Quality

- Satisfies all NHBC requirements
- Manufactured to BS EN ISO 9001 and BS EN ISO 14001
- Complies with all relevant Building Regulations
- Meets all relevant British Standards

Material and Colour Choice

- All products are vacuum formed in 2.0mm thick rigid polyethylene
- Available in black only

Products in the Range

Horizontal cavity trays: The main cavity tray component. Sections join together by means of a lapped joint, sealed with factory applied butyl mastic tape, to form the main cavity tray run. Water is gathered by the cavity tray and is discharged from the wall through a series of weep holes.

Corner units: Allows the integrity of the main cavity tray run to be maintained when it is necessary to turn a corner on a building. External or internal.

Stopends: Fitted at the start and finish of the cavity tray run to seal off the open ends and prevent water running back into the cavity.

Product codes

Description	Length	Product Codes To suit clear cavity widths of:			
		50-74mm	75-99mm	100-124mm	125-150mm
Horizontal tray	880/830mm	2075/880/50	2075/880/75	2075/880/100	2075/880/150
Horizontal tray	460/410mm	2075/460/50	2075/460/75	2075/460/100	2075/460/150
External 90° corner	N/A	2010/50	2010/75	2010/100	2010/150
Internal 90° corner	N/A	2011/50	2011/75	2011/100	2011/150
External 135° corner	N/A	2012/50	2012/75	2012/100	2012/150
Internal 135° corner	N/A	2013/50	2013/75	2013/100	2013/150
Stopend RH	N/A	2003/50	2003/75	2003/100	2003/150
Stopend LH	N/A	2004/50	2004/75	2004/100	2004/150

For trays featuring the polystyrene strip mortar barrier insert 'P' at the end of the required product code. This may incur additional charge.

Installation Advice

- Weep holes (1143 or Invisiweep) must be provided every 900mm along the cavity tray run to comply with Building Reg. requirements
- Each component fits to the next by means of a lapped joint that is sealed with butyl mastic tape. Surfaces must be clean and dry otherwise a good seal will not be formed
- With pre-formed cavity trays such as the System 2000 it is not strictly necessary for the cavity tray to span all the way across the cavity. As long as the cavity tray stands back from the rear face of the external wall and projects back into the cavity far enough to intercept drips falling from the wall ties, then it will perform effectively

How to Order

- To calculate quantities divide the overall length of the cavity tray run by 830mm. If the calculation does not come to an exact figure, round up to the next whole number. The 410mm length can be used as a make up piece to reduce waste and cost
- If the cavity tray is required to turn a corner, ensure that the correct corner units are ordered
- Always order stopends - typical installations require one right hand and one left hand stopend for the start and finish of the run
- Always state the clear cavity width when ordering

Bill of Quantity

F30 Accessories/sundry items for brick/block/stone walling
Clause

370 PREFORMED CAVITY TRAY / ACCESSORIES

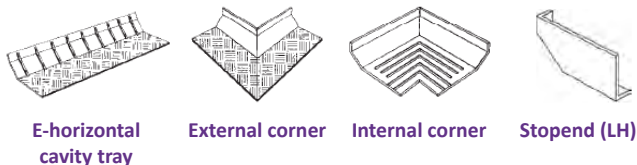
- Manufacturer: Timloc Building Products, Timloc House, Ozone Park, Howden, East Yorkshire, DN14 7SD. T: 01405 765567 W: www.timloc.co.uk
- Type(s) and location(s): Cavity tray supplied to be installed over horizontal abutments on new build applications, ring beam systems, airbricks, cavity liners, meter boxes, ducts etc.
- Build in carefully in accordance with manufacturer's recommendations to ensure a fully watertight installation.
- Reference: e.g. 2075/880 (830mm effective length)
- Optional Accessories: e.g. 2010 External Corner 90 Degree



Scan to view the full product page on the Timloc website

System 2000E Horizontal Cavity Trays for Refurbishment

Horizontal cavity tray system for remedial work on existing walls



Use

- For remedial work where a horizontal cavity tray must be inserted into an existing wall
- At the abutment of a flat roof with a cavity wall
- At the abutment of a lean-to or mono pitch roof with a cavity wall
- Over airbricks, cavity liners, ducts, meter boxes, etc.
- On external walls - not exceeding 102.5mm in thickness - built from standard brickwork, blockwork or stone
- Clear Cavity widths of between 50mm-125mm
- For wider cavity widths contact Timloc Technical

Features and Benefits

- Compact size and design allows insertion into an existing wall without ever having to remove more than three bricks at any one time
- Low profile lapped joint between sections allows for variations in brick size
- Angled section between cavity tray base and rear upstand automatically sheds water to the outer leaf
- Cavity tray builds into the outer leaf only, so there is no need to disturb the inner wall of the building
- The system is available upon request with pre-applied polystyrene strips. Polystyrene is much easier to rake out than mortar and offers a visual locator of the cavity tray so aiding the installation of post fitted lead work. This may incur additional charge.

Quality

- BBA approved
- Satisfies all NHBC requirements
- Manufactured to BS EN ISO 9001 : BS EN ISO 14001
- Complies with all relevant Building Regulations
- Meets all relevant British Standards

Material and Colour Choice

- All products are vacuum formed in 2.0mm thick rigid polyethylene
- Available in black only

Products in the Range

Horizontal cavity trays: The main cavity tray component. Sections join together by means of a lapped joint, sealed with factory applied butyl mastic tape, to form the main cavity tray run. Water is gathered by the cavity tray and is discharged from the wall through a series of weep holes.

Corner units: Allows the integrity of the main cavity tray run to be maintained when it is necessary to turn a corner on a building. Available in either external or internal format.

Stopends: Fitted at the start and finish of the cavity tray run to seal off the open ends and prevent water running back into the cavity.

How to Order

- To calculate quantities divide the overall length of the cavity tray run by 440mm. If the calculation does not come to an exact figure, round up to the next whole number
- If the cavity tray is required to turn a corner, ensure that the correct, corner units are ordered
- Always order stopends - typical installations require one right hand and one left hand stopend for the start and finish of the run
- Always state the clear cavity width when ordering

Installation Advice

- Each component is available to suit cavity widths of 50-74mm, 75-99mm and 100-125mm - make sure you select the correct width for the project in hand
- Weep holes (1143 or Invisiweep) must be provided every 900mm along the cavity tray run to comply with Building Reg. requirements.
- Each component fits to the next by means of a lapped joint that is sealed with butyl mastic tape. Surfaces must be clean and dry otherwise a good seal will not be formed
- With pre-formed cavity trays such as the System 2000E it is not strictly necessary for the cavity tray to span all the way across the cavity. As long as the cavity tray stands back from the rear face of the external wall and projects back into the cavity far enough to intercept drips falling from the wall ties, it will perform effectively

Bill of Quantity

F30 Accessories/sundry items for brick/block/stone walling
Clause

370 PREFORMED CAVITY TRAY / ACCESSORIES

- Manufacturer: **Timloc Building Products, Timloc House, Ozone Park, Howden, East Yorkshire, DN14 7SD. T: 01405 765567 W: www.timloc.co.uk**
- Type(s) and location(s): Cavity tray supplied to be installed over horizontal abutments on new build applications, ring beam systems, airbricks, cavity liners, meter boxes, ducts etc.
- Build in carefully in accordance with manufacturer's recommendations to ensure a fully watertight installation.
- Reference: 2005E Horizontal Tray (440mm effective length)
- Optional Accessories: e.g. 2006E External Corner 90 degree

Product Codes

Description	Length	Product Codes		
		To suit clear cavity widths of:		
		50-74mm	75-99mm	100-125mm
Horizontal tray	460/440mm	2005/50	2005/75	2005/100
External 90° corner	N/A	2006E/50	2006E/75	2006E/100
Internal 90° corner	N/A	2007E/50	2007E/75	2007E/100
Stopend RH	N/A	2003/50	2003/75	2003/100
Stopend LH	N/A	2004/50	2004/75	2004/100

Alternatively the Inter-loc system is also suitable for remedial work.

For trays featuring the polystyrene strip mortar barrier insert 'P' at the end of the required product code. This may incur additional charge.

For wider cavity widths contact Timloc Technical



Scan to view the full product page on the Timloc website

Inter-loc Horizontal Cavity Trays - Lead Attached

Preformed leaded cavity tray system for new build



4 brick (300mm drop lead)
IL4



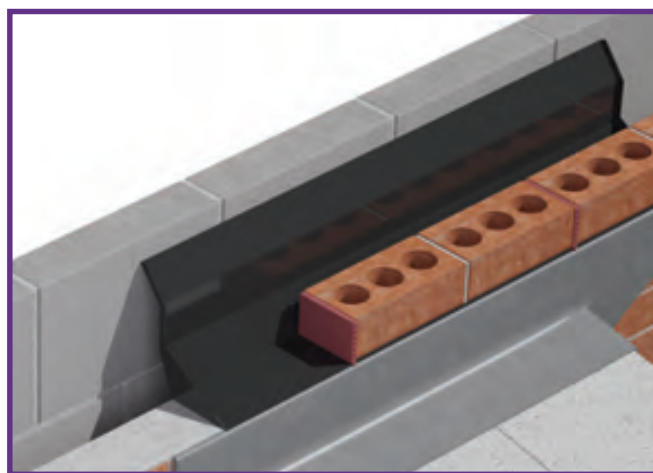
2 brick (150mm drop lead)
IL2



External corner
(300mm drop lead)



Internal corner
150mm (drop lead range)



Use

- At the abutment of a flat roof with a cavity wall
- At the abutment of a lean-to or mono pitch roof with a cavity wall
- On external walls - not exceeding 102.5mm in thickness - built from standard brickwork, blockwork or stone
- Clear cavity widths of between 50mm-125mm

Features and Benefits

- Supplied with factory fitted lead flashing ready cut to suit the pitch of the roof and type of roof covering
- Fits all cavity sizes up to 125mm
- Suitable for brick, block and stone wall construction (cutting of masonry may be required)
- 150mm high back upstand exceeds minimum requirements
- Angled section between cavity
- Interlocking mechanism for joining tray lengths to eliminate tray jointing
- Built to brick bonding lengths for ease of use
- Angled section between cavity tray base and rear upstand automatically sheds water to the outer leaf
- Built independent to the inner leaf will enable inner and outer leaves to be built independently, if required
- Available in two lengths: 4 brick (900mm) for general use and 2 brick (450mm) for reducing waste when making up a run of cavity tray to the required length

Quality

- Satisfies all NHBC requirements
- Manufactured to BS EN ISO 9001 and BS EN ISO 14001
- Complies with all relevant Building Regulations
- Meets all relevant British Standards

Material and Colour Choice

- Flashings are Code Blue milled lead as standard as defined by BS EN 12588 : 1999 (formally known as Code 4)
- Horizontal Inter-loc units are injection moulded in 2mm polypropylene
- Accessories are vacuum formed in 2mm medium density polyethylene
- Available in black only

Products in the Range

Horizontal Inter-loc cavity trays: The main cavity tray component sections join together by means of a lapped interlocking joint, to form the main cavity tray run. Water is gathered by the cavity tray and is discharged from the wall through a series of weep holes - one weep hole per Inter-loc tray is required (1143 or Invisiweep).

Corner units: Allows the integrity of the main cavity tray run to be maintained when it is necessary to turn a corner on a building. Available in either external or internal format.

Stopends: Fitted at the start and finish of the cavity tray run to seal off the open ends and prevent water running back into the cavity.

Installation Advice

- Each component is available to suit clear cavity widths of either 50-125mm
- Weep holes must be provided in every cavity tray to comply with Building Regulation requirements. These can be formed by installing a purpose made Timloc plastic wall weep unit
- Each Inter-loc cavity tray fits to the next by means of a lapped interlocking joint, as work proceeds while working from right to left
- With rigid pre-formed cavity trays such as the Inter-loc system it is not necessary for the cavity tray to span all the way across the cavity. As long as the cavity tray stands back from the rear face of the external wall and projects back into the cavity far enough to intercept drips falling from the wall ties, then it will perform effectively

Contact Timloc Technical department for installation guidance.

How to Order

- To calculate quantities divide the overall length of the cavity tray run by .225 (representing one brick and joint) to give number of bricks required then divide by 2 for IL2 or 4 for IL4 to give tray quantity. Always round up to the next tray because excess length can be cut away
- If the cavity tray is required to turn a corner, ensure that the correct corner units are ordered
- Please use stopends if the cavity tray has to be cut down to suit the project
- Stopends will not be required when the cavity tray run is built within the body of the building i.e. bay windows. For this application the integrated stopend can be built into the next available joint projecting past the abutting roof
- Contact our Technical Department for pricing and assistance

Product Codes

New build applications with lead attached - 150mm drop lead

Description	Effective Length	Product Code
Inter-loc horizontal tray	4 brick/900mm	IL4L150
Inter-loc horizontal tray	2 brick/450mm	IL2L150
External 90° corner	1 brick/220mm	EXT90L150
Internal 90° corner	1 brick/220mm	INT90L150
External 135° corner	330mm	EXT135L150
Internal 135° corner	150mm	INT135L150

New build applications with lead attached - 300mm drop lead

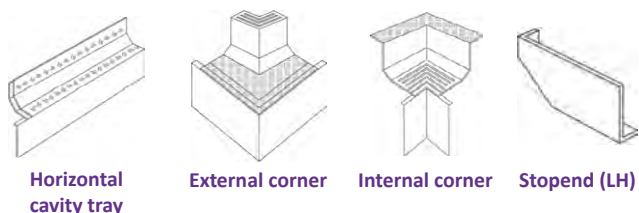
Description	Effective Length	Product Code
Inter-loc horizontal tray	4 brick/900mm	IL4L300
Inter-loc horizontal tray	2 brick/450mm	IL2L300
External 90° corner	1 brick/220mm	EXT90L300
Internal 90° corner	1 brick/220mm	INT90L300
External 135° corner	330mm	EXT135L300
Internal 135° corner	150mm	INT135L300



Scan to view the full product page on the Timloc website

System 2000 Horizontal Cavity Trays Lead Attached

Horizontal leaded cavity tray system for all types of brick, block and stone new build constructions



Use

- At abutment of a lean-to, flat or mono pitch roof and cavity wall
- On external walls - not exceeding 102.5mm in thickness - built from standard brickwork, blockwork or stone
- Clear cavity widths of between 50mm-125mm
- For wider cavity widths contact Timloc Technical

Features and Benefits

- Supplied with factory fitted lead flashing, cut ready for dressing
- 150mm high back upstand exceeds minimum requirements
- Low profile lapped joint between sections allows any length of brick, block or stone to be used without difficulty
- Angled section between cavity tray base and rear upstand automatically sheds water to the outer leaf
- Cavity tray builds into the outer leaf only to speed up installation and allow both inner and outer leaves to be built independently
- Choice of two lengths: 880mm for general use; 460mm to reduce waste when making up a run of cavity tray to the required length

Quality

- Manufactured to BS EN ISO 9001 and BS EN ISO 14001
- Complies with all relevant Building Regulations
- Meets all relevant British Standards and NHBC requirements

Material and Colour Choice

- Vacuum formed in 2.0mm thick rigid polyethylene. Black only
- Flashings are Code Blue (milled lead as standard) as defined by BS EN 15288:1999 (formally known as Code 4)

Products in the Range

Horizontal cavity trays: The main cavity tray component. Sections join together by means of a lapped joint, sealed with factory applied butyl mastic tape, to form the main cavity tray run. Water is gathered by the cavity tray and is discharged from the wall through a series of weep holes.

Corner units: Allows the integrity of the main cavity tray run to be maintained when it is necessary to turn a corner on a building. External or internal.

Stopends: Fitted at the start and finish of the cavity tray run to seal off the open ends and prevent water running back into the cavity.

Product codes

Description	Length	Product Codes To suit clear cavity widths of:		
		50-74mm	75-99mm	100-125mm
Horizontal tray	880/830mm	2075/880/50	2075/880/75	2075/880/100
Horizontal tray	460/410mm	2075/460/50	2075/460/75	2075/460/100
External 90° corner	Short lead	2010L150/50	2010L150/75	2010L150/100
External 90° corner	Long lead	2010L300/50	2010L300/75	2010L300/100
Internal 90° corner	Short lead	2011L150/50	2011L150/75	2011L150/100
Internal 90° corner	Long lead	2011L300/50	2011L300/75	2011L300/100
External 135° corner	Long lead	2012L300/50	2012L300/75	2012L300/100
External 135° corner	Long lead	2012L450/50	2012L450/75	2012L450/100
Internal 135° corner	Long lead	2013L300/50	2013L300/75	2013L300/100
Internal 135° corner	Long lead	2013L450/50	2013L450/75	2013L450/100
Stopend RH	N/A	2003/50	2003/75	2003/100
Stopend LH	N/A	2004/50	2004/75	2004/100

For trays featuring the polystyrene strip mortar barrier insert 'P' at the end of the required product code. This may incur additional charge.

Installation Advice

- Each component is available to suit cavity widths of 50-74mm, 75-99mm and 100-125mm - please select the correct width
- Weep holes must be provided every 900mm along the cavity tray run to comply with Building Regulation requirements. These can be formed by installing a purpose made Timloc plastic wall weep unit
- Each component fits to the next by means of a lapped joint that is sealed with butyl mastic tape.
- Surfaces must be clean and dry otherwise a good seal will not be formed in areas of severe weather exposure, customers should consider specifying a heavier code of lead and/or mechanically fixing and sealing the lead to prevent uplift

How to Order

- To calculate quantities divide the overall length of the cavity tray run by 830mm. If the calculation does not come to an exact figure, round up to the next whole number. The 410mm length can be used as a make up piece to reduce waste and cost
- If the cavity tray is required to turn a corner, ensure that the correct corner units are ordered
- Always order stopends - typical installations require one right hand and one left hand stopend for the start and finish of the run
- Always state the clear cavity width when ordering

Bill of Quantity

F30 Accessories/sundry items for brick/block/stone walling
Clause

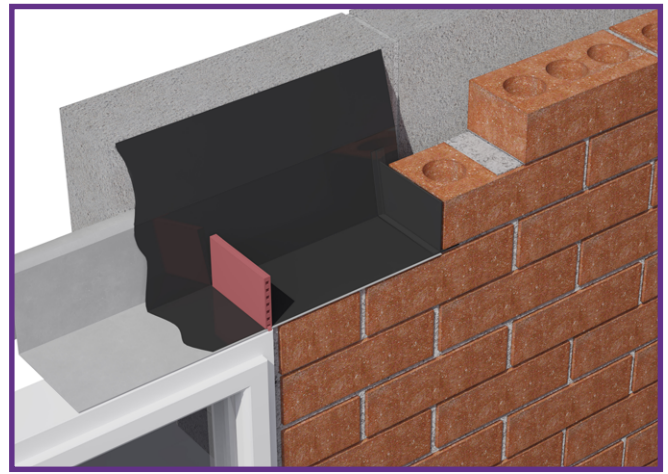
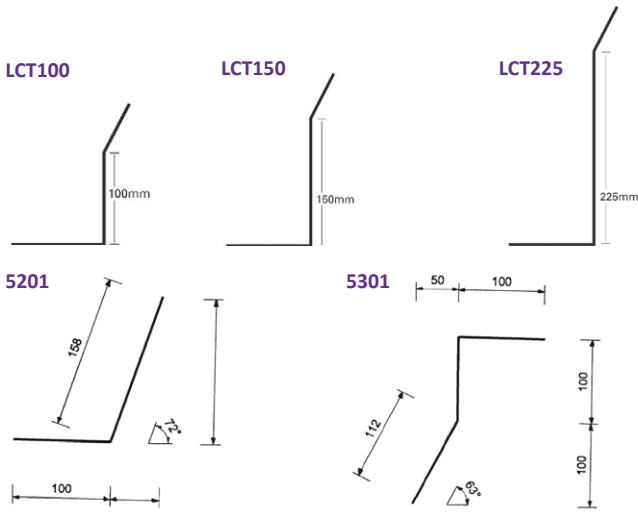
370 | PREFORMED CAVITY TRAY / ACCESSORIES

- Manufacturer: Timloc Building Products, Timloc House, Ozone Park, Howden, East Yorkshire, DN14 7SD. T: 01405 765567 W: www.timloc.co.uk
- Type(s) and location(s): Cavity tray supplied with attached lead flashing to be installed over horizontal roof abutments on new build applications.
- Build in carefully in accordance with manufacturer's recommendation to ensure a fully watertight installation.
- Cavity Width: ...
- Reference: e.g. 2075/880 L (830mm effective length) 150mm lead
- Optional Accessories: .e.g. 2010 L External Corner 90 Degree (150mm lead)

State whether long (300mm) or short (150mm) leads are required. Long leads are used where flashing is required to dress directly over the top of the roof tile. Short leads are used where there is a soaker or secret gutter detail.

Over Lintel, General Purpose & Parapet Horizontal Cavity Trays

A range to protect modern steel lintels, general purpose horizontal and parapet cavity applications



Bill of Quantity

F30 Accessories/sundry items for brick/block/stone walling

Clause

485^ PREFORMED CAVITY TRAY / ACCESSORIES

- Manufacturer: Timloc Building Products, Timloc House, Ozone Park, Howden, East Yorkshire, DN14 7SD. T: 01405 765567 W: www.timloc.co.uk
- To extend not less than 150mm beyond ends of lintels/bridgings.
- Reference: **LCT lintel cavity trays**
- Lintel Rise: **(100mm, 150mm or 225mm)**
- Cavity width: **(50mm, 75mm or 100mm)**

Use

- Over steel lintels in external cavity walls (LCT)
- General purpose horizontal cavity applications such as floor beams, abutments and meter boxes (GCT)
- For parapet walls (HPT)

Features and Benefits

- Fully self supporting cavity tray system built independently from inner leaf
- Available for all coursing heights and styles with options available to suit all cavity variations
- Full range of cut to length sizes available
- No site fabrication, no waste, easy to handle and install
- Consistency and build quality maintained, cost effective

Quality

- Tough, durable, scratch resistant and puncture resistant
- Manufactured to BS ISO 9001 and BS EN 14001
- Meets all relevant British Standards
- Meets all documented cavity tray requirements
- Meets all NHBC recommendations

Material and Colour Choice

- Manufactured from black 2mm polypropylene
- A high quality product that is rigid yet durable for site conditions

Installation Advice - Lintel Trays

- Lintel cavity trays must be combined with lintel stopends and proprietary weep hole units to achieve their full potential of being a system which offers maximum water catchment and discharge properties for above openings
- Standard length 2.5mtrs in one piece

Contact Timloc Technical department for installation guidance.

How to order - Lintel Trays

- Two stopends and weep holes at 450mm centres (minimum of two weep holes) are required per lintel/tray
- Consult lintel manufacturer to confirm lintel upstand height and select next available LCT height (either 100mm, 150mm or 225mm)
- Calculate the length of LCT required by adding a minimum of 300mm to length of lintel. This will give adequate cavity tray length to allow stopends to be inserted into the next perp joint away from the opening
- Add the appropriate LCT length to the product code before ordering
- The standard range of lintel cavity tray has been designed to suit the most popular types of steel lintel

Contact Timloc Technical department for General Purpose Trays and Parapet Horizontal Cavity Trays.

Product Codes

LCT lintel, GCT and HPT horizontal cavity trays

Description	Colour	Product Codes		
		To suit clear cavity widths of:		
		50mm	75mm	100mm
LCT100 Lintel tray	Black	5001	5002	5003
LCT150 Lintel tray	Black	5004	5005	5006
LCT225 Lintel tray	Black	5007	5008	5009
GCT50 Horizontal tray	Black	5201	-	-
GCT75 Horizontal tray	Black	-	5202	-
GCT100 Horizontal tray	Black	-	-	5203
HPT50 Horizontal tray	Black	5301	-	-
HPT75 Horizontal tray	Black	-	5302	-
HPT100 Horizontal tray	Black	-	-	5303

Trays to suit clear cavity widths of 101mm+ can be made to order.

Corners, stopends and joining tape are available to offer a fully sealed/ water tight system. Other variants of GCT available to order.



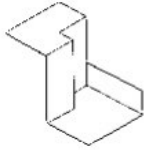
Scan to view the full product page on the Timloc website

Purpose Made Cavity Trays

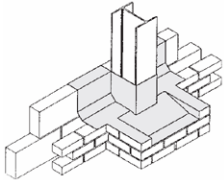
Special made to measure damp proof course units for dpc applications



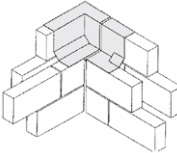
Threshold trays



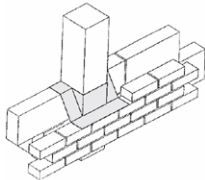
Corner / column stopends



Pier & column cloaks



Corner expansion joints



Straight column cloaks

Use

- Wherever DPC is used to form a horizontal cavity tray
- To substitute the cutting, moulding and sealing of a DPC when forming cavity trays, angles, stop ends and column cloaks

Features and Benefits

- One piece seamless mouldings eliminate the need for site fabrication to prevent errors through poor workmanship
- Tailor-made to order - manufactured to suit exact customer requirements with delivery to site usually within 10-14 working days
- Easy to handle, flexible, tough, durable and puncture resistant
- Fully compatible with all Timloc DPC and cavity tray systems
- Can be used for multi-storey or high loading applications - will not extrude under loads up to the point of compressive failure of wall
- Wide range of standard components with special, tailor-made accessories also readily available

Quality

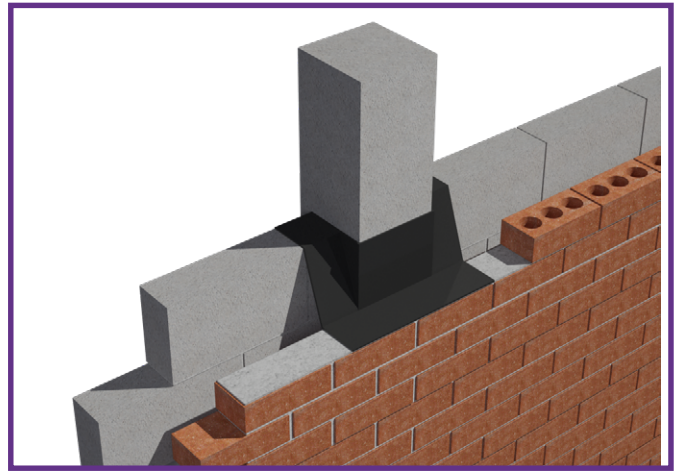
- Manufactured to BS EN ISO 9001 and BS EN ISO 14001
- Design principals comply with all relevant Building Regulations and relevant British Standards

Material and Colour Choice

- Vacuum formed in 2mm medium density polyethylene
- In line heat bending in 2mm polypropylene
- Available in black only

Products in the Range

- Cavity trays for brick support systems
- Pier, column and corner cloaks
- Threshold trays
- Change of level units
- Stop end and junction cappings
- Radius units
- Ring beam cavity tray systems
- Parapet cavity tray systems



Installation Advice

- As with all DPC systems, purpose made units should always be bedded on to fresh mortar, never dry bedded. The masonry laid over the DPC and purpose made unit should also be bedded on to fresh mortar so that the DPC system is approximately half way through the thickness of the mortar joint
- Continuation of DPC must be lapped on to the purpose made unit by a minimum of 100mm
- All lapped joints must be fully sealed with jointing tape (not all units are supplied with jointing tape attached). It is essential that the jointing surfaces are clean and dry or the jointing surfaces will not seal correctly
- All DPC items should be installed to relevant codes of practice

Bill of Quantity

F30 Accessories/sundry items for brick/block/stone walling

Clause

385 | PREFORMED DPC / CAVITY TRAY JUNCTION CLOAKS / STOPENDS

- Manufacturer: Timloc Building Products, Timloc House, Ozone Park, Howden, East Yorkshire, DN14 7SD. T: 01405 765567 W: www.timloc.co.uk
- Type(s) and location(s): Preformed made to measure Cavity tray to be designed to fit around non standard bespoke applications, such as columns, wind posts, corners, lintels etc
- Seal all laps with dpc and/or cavity trays using adhesive/mastic in accordance with manufacturers recommendations to ensure a fully watertight installation.
- Reference: Timloc Purpose Made Cavity Trays
- Types shown on drawings.

How to Order

Cavity trays are made to order, so please supply full construction details. Ideally these will include a fully dimensioned drawing.



Scan to view the full product page on the Timloc website

Cavity Trays for Door and Window Openings

Tailor-made cavity tray systems for all types of door/window arches and circular windows

CAVITY TRAYS

Use

- Around the opening of an external door or window with an arched top or a circular external window
- On external walls - built from brick, block or stone as well as timber frame constructions - of any thickness and any cavity width

Features and Benefits

- One piece seamless mouldings eliminate the need for site fabrication to prevent errors through poor workmanship
- Tailor-made to order - manufactured to suit exact customer requirements with delivery to site usually within 10-14 working days
- Any size, type or radius of curve can be fabricated
- Can be supplied in two or more sections to allow adjustment on site and easily compensate for building tolerances
- Easy to handle, flexible, tough, durable and puncture resistant
- Fully compatible with all Timloc DPC and cavity tray systems
- Can be used for multi-storey or high loading applications - will not extrude under loads up to the point of compressive failure of wall
- Wide range of standard components with special, tailor-made accessories also readily available

Quality

- Satisfies all NHBC requirements
- Manufactured to BS EN ISO 9001 and BS EN ISO 14001
- Complies with all relevant Building Regulations
- Meets all relevant British Standards

Material and Colour Choice

- All products are vacuum formed in 2.0mm thick medium density polyethylene
- Available in black only

Installation Advice

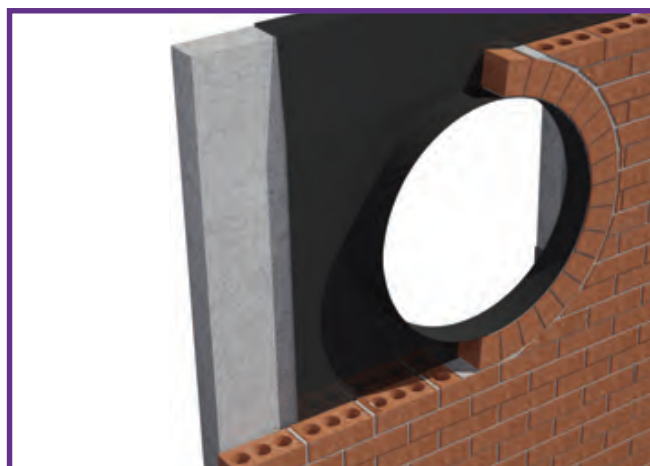
- Under normal circumstances the arch and bullseye cavity tray is positioned so that the upstand fits between the door/window frame and the external brickwork. After installation the upstand can be trimmed back flush with the frame and sealed with exterior mastic in the normal way
- Weep holes must be provided at the base of the arch cavity tray at both sides of the opening. These can be formed by installing a purpose made Timloc plastic wall weep unit (product 1143/Invisiweep)
- When the arch and bullseye cavity tray is supplied in two or more sections, each section fits to the next by means of a lapped joint that is sealed with butyl mastic tape. Surfaces must be clean and dry otherwise a good seal will not be formed
- Arch and bullseye cavity trays are usually supplied with an integral flap which builds in to the inner leaf to ensure it is held securely in position. If building-in is not possible. e.g. with a timber frame construction, the cavity tray flap should be mechanically fixed to the inner leaf.

Contact Timloc Technical department for installation guidance.

How to Order

Arch cavity trays are made to order, so please supply full construction details. Ideally these will include a fully dimensioned drawing showing door/window opening size and wall construction details. If this is not possible the minimum information required is:

- Thickness of outer leaf and cavity width
- Clear opening width and height of door/window opening
- Radius of curvature
- Position of spring line
- With this data Timloc will be able to produce and despatch a dimensioned drawing for your approval.



Bill of Quantity

F30 Accessories/sundry items for brick/block/stone walling
Clause

385 | PREFORMED DPC / CAVITY TRAY JUNCTION CLOAKS / STOPENDS

- Manufacturer: Timloc Building Products, Timloc House, Ozone Park, Howden, East Yorkshire, DN14 7SD. T: 01405 765567, W: www.timloc.co.uk
- Type(s) and location(s): Preformed Arch Cavity Tray to be positioned directly over external arch window features/lintels.
- Seal all laps with dpc and/or cavity trays using adhesive/mastic in accordance with manufacturers recommendations to ensure a fully watertight installation.
- Reference: SPA Arch Dpc Cavity Tray
- Diameter: Types & sizes as shown on drawings/window schedule.

Bill of Quantity

F30 Accessories/sundry items for brick/block/stone walling
Clause

385 PREFORMED DPC / CAVITY TRAY JUNCTION CLOAKS / STOPENDS

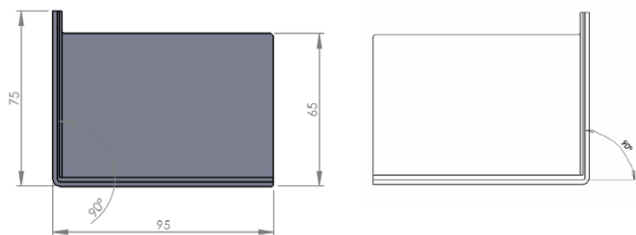
- Manufacturer: Timloc Building Products, Timloc House, Ozone Park, Howden, East Yorkshire, DN14 7SD. T: 01405 765567, W: www.timloc.co.uk
- Type(s) and location(s): Preformed Circular Cavity Tray to be positioned directly around external circular window features/lintels.
- Seal all laps with dpc and/or cavity trays using adhesive/mastic in accordance with manufacturers recommendations to ensure a fully watertight installation.
- Reference: SPB Bullseye Dpc Cavity Tray
- Diameter: Types & sizes as shown on drawings/window schedule.



Scan to view the full product page on the Timloc website

Lintel Stopend

Profile to protect modern steel lintels



Use

- On steel lintels situated in external walls
- On external walls - not exceeding 102.5mm in thickness - built in standard brick, block or stone

Features and Benefits

- Purpose made and pre-formed to guarantee an accurate fit on most popular types of steel lintel
- Far more accurate and reliable than site-formed stopends, or than folding up the ends of the over-lintel DPC
- Factory fitted butyl mastic seal ensures a secure and watertight bond to the lintel

Quality

- Satisfies all NHBC requirements
- Manufactured to BS EN ISO 9001 and BS EN ISO 14001
- Complies with all relevant Building Regulations
- Meets all relevant British Standards

Material and Colour Choice

- Injection moulded in polypropylene
- Available in black only

Installation Advice

- Use wherever water could collect on an external lintel. Designed to prevent water running off the ends of the lintel and back into the cavity
- To work effectively lintel stopends should be placed directly on top of the front flange of the lintel, or over-lintel DPC, as close to the ends as the brick bonding will allow
- The area on the lintel where the lintel stopends are placed must be clean and dry otherwise the pre-applied butyl mastic tape will not seal correctly

Contact Timloc Technical department for installation guidance.



How to Order

- Two stopends are required per lintel

Product Code

Description	Product Code
Lintel stopend	LS01



Scan to view the full product page on the Timloc website

CAVITY TRAYS | TECHNICAL INFORMATION AND INSTALLATION ADVICE

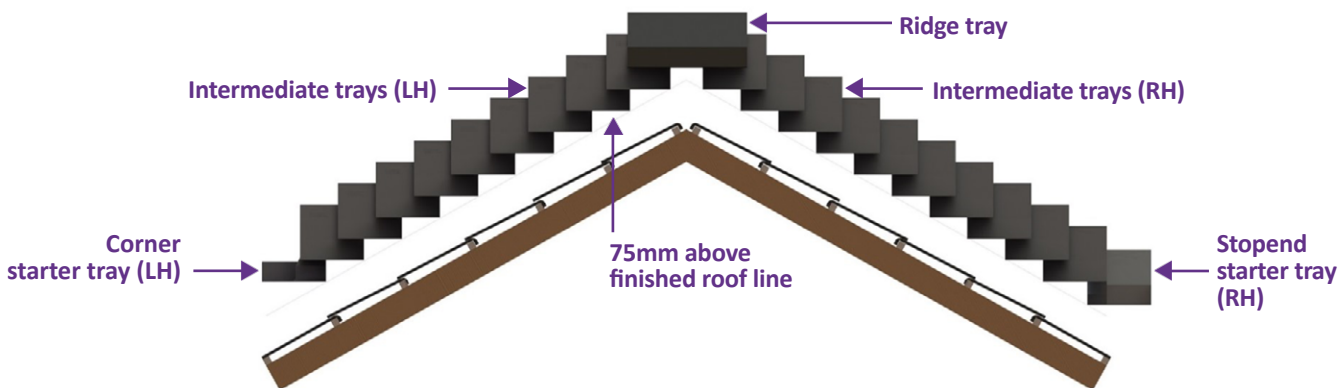
Please read these instructions carefully before starting work. For any clarifications, contact the Timloc Technical department.

Cavity trays must always be bedded onto fresh mortar, never dry bedded.

The masonry which is then laid over the cavity trays must also be bedded onto fresh mortar with the result that the base of the cavity tray is positioned approximately half way through the mortar joint.

General Impression

How a complete cavity tray system should be set out:



Lead Flashings

In most cases, a cavity tray will be required to work in conjunction with a lead flashing at a roof/wall abutment. The cavity tray protects the inside of the outer leaf and the cavity and the lead flashing protects the face of the outer leaf and the junction between the roof covering and the wall.

The lead flashings associated with cavity trays can be dealt with in one of two ways. Either as a factory-fitted integral part of the cavity tray or as an independent flashing fitted separately to the cavity tray. When specifying or installing cavity trays and lead flashings it is important to consider the following recommendations:

- In the case of stepped cavity trays it is very important to specify the exact pitch of the roof. The lead flashings are accurately cut to suit the specified pitch and will look aesthetically incorrect if used on any other roof pitch
- All leaded cavity trays are available with a choice of 'long' or 'short' leads and it is important to specify which is preferred. The general rule is that long leads are used where the flashing is required to dress down over the surface of the roof covering and short leads are used in conjunction with a separate soaker or secret gutter detail. It is important to remember that this is just a general rule and many specifiers and end users have their own preferences as to how the flashings should be dressed. Timloc must be informed of any specific requirements.

Short Leads



Long Leads



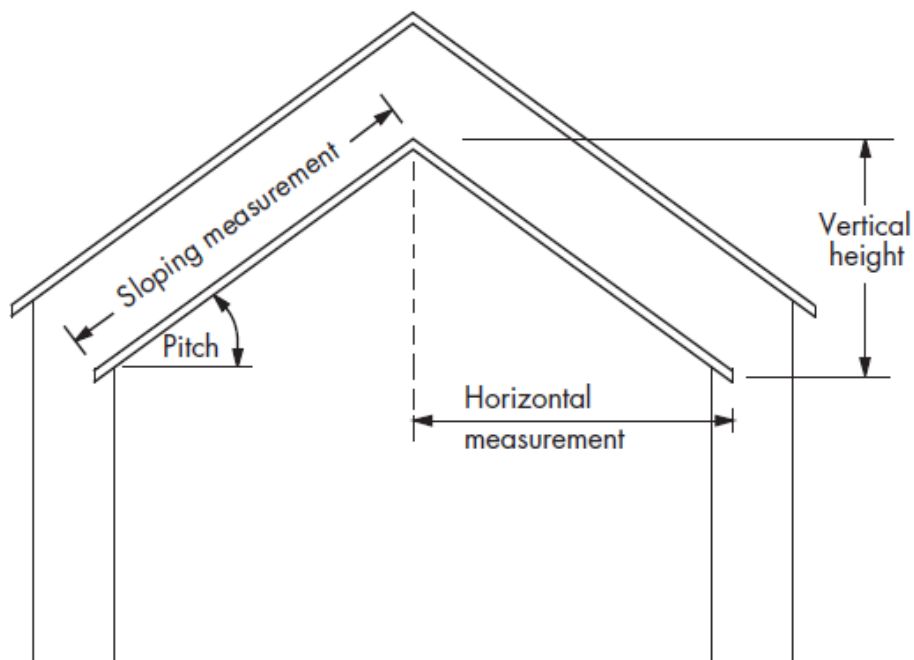
Product Selection

Timloc recommend that customers take advantage of our Technical service which is freely available to all users and specifiers of Timloc products. The Technical department will be pleased to advise on the most suitable products to meet the application and can also prepare a fully itemised schedule of quantities.

Please provide as much information as possible, including drawings if they are available. All enquiries should include the following information as a minimum requirement:

- The materials used for construction of the outer leaf, i.e. brick, block or stone, including the bed thickness and course height
- The overall structural cavity width within the wall
- The type and thickness of any insulation material used within the wall cavity
- The pitch of the roof (in the case of pitched roof abutments)
- The type of roof covering or state whether long or short leads are required (in the case of leaded cavity trays)
- Clear dimensional information or accurate scale drawings relevant to the areas requiring cavity trays
- Comments with regard to the weather exposure of the site
- Any specific or non-standard requirements are to be clearly stated

Measurement Areas



Cavity Tray Scheduling

Timloc Building Products offer a free scheduling/estimating service for our full range of products, we primarily and most frequently schedule for cavity trays as there are numerous variations of products to suit specific applications.

Our schedule format can be produced to your individual instruction i.e. specific to site, house types, blocks, plots and even area of application to give a comprehensive and accurate schedule.

Technical | Kerry Taylor

Technical Manager

T: 01405 782 769

E: technical@timloc.co.uk



If you require further information, clarification, or to enquire about our call-off and scheduling service please get in touch with the Timloc Building Products Technical Department and we will be happy to assist.

Product datasheets are also available at: www.timloc.co.uk

Technical | Miriam Green

Technical Sales Executive

T: 01405 782 769

E: technical@timloc.co.uk



AS

AMBI-SOAKER

DRY FIX LEAD REPLACEMENT SOAKERS

AMBI-SOAKER PLAIN

Ambi-Soaker Universal Dry Fix Abutment Soaker for Plain Tiles

P. 112

AMBI-SOAKER INTERLOCKING PLAIN

Ambi-Soaker Universal Dry Fix Abutment Soaker for Interlocking Plain Tiles

P. 113

AMBI-SOAKER SLATES

Ambi-Soaker Universal Dry Fix Abutment Soaker for Slates

P. 114

AMBI-SOAKER THIN LEADING EDGE

Ambi-Soaker Universal Dry Fix Abutment Soaker for Thin Leading Edge Tiles

P. 115

AMBI-SOAKER FLAT

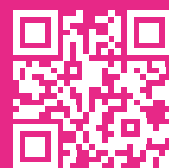
Ambi-Soaker Universal Dry Fix Abutment Soaker for Large Format Flat Tiles

P. 116

CAVITY CLOSERS & STOP SOCKS

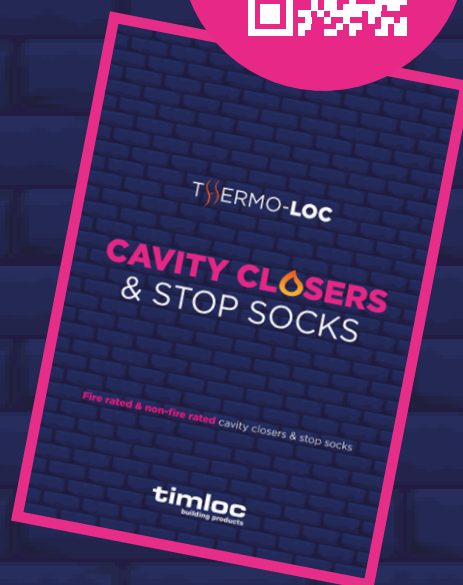
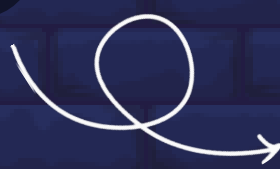
Product	Page No.
Cavity Closers, Barriers & Stop Socks Table	48
Thermo-loc Platinum Multi Cavity Closer	49
Thermo-loc Platinum + Cavity Closer	50
Thermo-loc Platinum + FX Cavity Closer	52
Thermo-loc FR30 30-Minute Fire Rated Cavity Closer	54
Thermo-loc FR60 60-Minute Fire Rated Cavity Closer	56
Thermo-loc FR60+ 60-Minute Fire Rated Cavity Closer	58
FRstop 60-Minute Fire Rated Cavity Stop Sock	60

SCAN
TO VIEW



**CATEGORY
GUIDE**

AVAILABLE



CAVITY CLOSERS & STOP SOCKS

Use the table below to establish which Timloc cavity closer is best suited to your project specification. Alternatively, get in touch with our Technical department who will be happy to assist with your enquiry:

	Thermo-Loc Platinum Multi	Thermo-Loc Platinum +	Thermo-Loc Platinum + FX	Thermo-Loc FR30	Thermo-Loc FR60	Thermo-Loc FR60+
Product Code	CC2.4PPS/...	PP2.4/...	FX2.4/...	CC2.4FR/...	FR60/...	FR60/...
Shape	T	C	C FX	C FX	C FX	C FX
Fire Rated	✗	✗	✗	✓	✓	✓
Check Reveal	✗	✓	✓	✓	✓	✓
Profile	50 - 100 single 100 - 150 single	50 - 100 single 105 - 150 double	50 - 100 single 105 - 150 double	50 - 100 single 105 - 300 double	50 - 100 single 105 - 150 single	150 - 300 single
Length	2.4m	2.4m	2.4m	2.4m	2.4m	2.4m
Thickness	20mm	25mm	25mm	25mm	30mm	50mm
Multi Option	✓ up to 150mm	✓ up to 100mm	✓ up to 100mm	✗	✗	✗
Building Reg. Parts C+L Compliant	✓	✓	✓	✓	✓	✓
Building Reg. Part B Compliant	✗	✗	✗	✓	✓	✓

We recommend that customers take advantage of the technical advisory service. Our technical services team will be pleased to advise on the most suitable products for the application and will prepare a fully itemised schedule of quantities if required.

Platinum Multi

Cavity closers for eliminating damp and cold bridging around doors, windows and sills

Use

- To close the cavity at external doors, window jambs and sills
- To provide thermal insulation and prevent 'cold bridging'
- To provide a DPC at external doors, window jambs or sills
- Suitable for cavities up to 150mm

Features and Benefits

- Provides an effective DPC and thermal barrier between frame, inner and outer wall leaf
- Thermal conductivity of 0.031W/mk
- Exceeds the minimum thermal resistance path of 0.45m² K/W stipulated in accredited construction details
- Rigid profile extrusion allows second fix
- Durable and resistant to decay
- Simple on-site trimming to cope with 'rogue' cavity widths
- Global warming potential of less than 5
- Ozone depletion potential of zero

Quality

- Manufactured to BS EN ISO 9001 and BS EN ISO 14001
- Complies with Building Regulation Approved Documents C, L1 & L2
- Satisfies BRE document 'Thermal insulation: avoiding risks'
- Meets all relevant British Standards
- Satisfies NHBC standards

Material and Colour Choice

- Rigid profile extruded in Grey UPVC
- Platinum expanded Polystyrene insulation 0.031W/mk
- Multi 100mm & Multi 150mm cavities
- 2.4m lengths

Installation Advice

- The accredited construction detail published by DCLG require a minimum overlap of 30mm between the window frame and cavity closer
- Cut into required lengths allowing the jamb section to overlap the sill section by cutting away parts of the fixing flange and butt the underside of the lintel
- For second fix applications, the cavity closer is pushed into the open cavity after building work is complete. The compressible nature of the exposed insulation material is used to create a friction fit in the cavity, alternatively the insulation can be trimmed to fit using a sharp knife
- Fixing nails to the flanges are recommended to ensure a secure fit

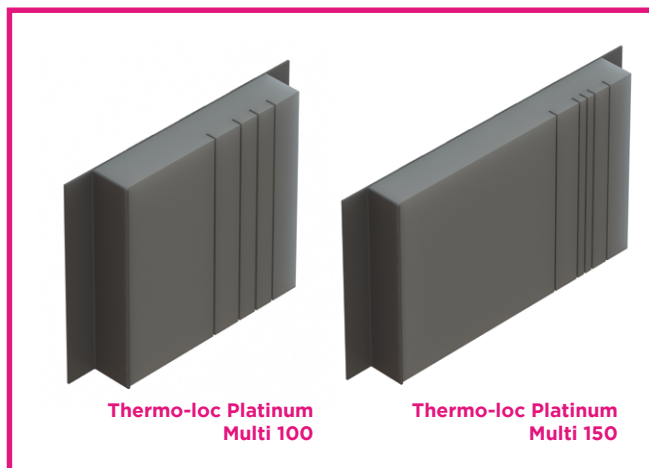
Technical Considerations

- BRE Document 'Thermal insulation: avoiding risks' stipulate "When a window or door frame is set back behind the inner face of a dense outer masonry leaf, it should overlap an insulated closer by a minimum of 30mm for BRE exposure zones Sheltered to Severe; but fully rebated for zones Very Severe".
- With reference to insulation, the products in this range do not use, contain or produce Urea Formaldehyde, CFC's or indeed any of the so called soft CFC's, ie. HCFC's & HFA's. They have an ozone depletion potential of zero and global warming potential of less than 5 and complies with BS EN 13163.

Bill of Quantity

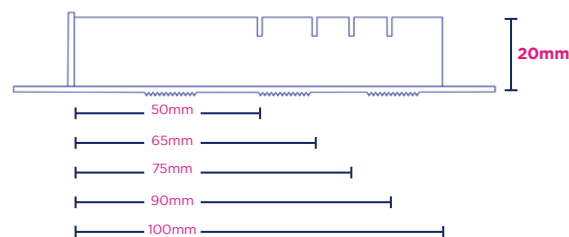
F30 Accessories/sundry items for brick/block/stone walling window jambs and sills
 Clause 180 | CAVITY CLOSURES FOR CLOSING AROUND WINDOW & DOOR OPENINGS

- To extend not less than 150mm beyond ends of lintels/bridgings.
- Manufacturer: Timloc Building Products, Ozone Park, Howden, East Yorks. DN14 7SD. T: 01405 765 567 W: www.timloc.co.uk
- Reference: eg. CC2.4PPS/Multi100 (Thermo-loc Platinum Multi, Expanded Polystyrene, 2.4m, multi cavity up to 100mm)

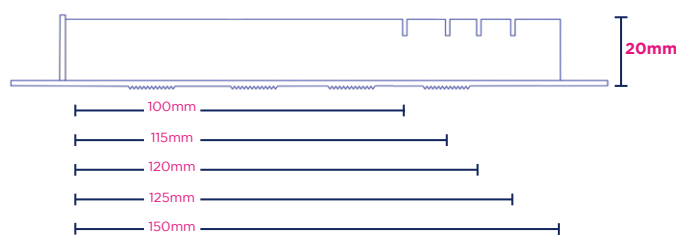


Product Dimensions

Standard Profile Multi 100 | 50mm - 100mm cavities



Standard Profile Multi 150 | 100mm - 150mm cavities



How to Order

- Establish the cavity width and select the correct cavity closer width to ensure the cavity can be closed
- In jamb and sill applications, first estimate the total length of cavity closer required, then order the correct number of individual 2.4 metre lengths so no joint pieces

Product Codes

Product Code	Cavity Width	Length	Pack Qty	Lead Time
CC2.4PPS/MULTI100	50-100mm	2.4m	10	Next working day
CC2.4PPS/MULTI150	100-150mm	2.4m	10	Next working day



Scan to view the full product page on the Timloc website

Platinum +

Cavity closers for eliminating damp and cold bridging around doors, windows and sills

Use

- To close the cavity at external doors, window jambs and sills
- To provide thermal insulation and prevent 'cold bridging'
- To provide a DPC at external doors, window jambs or sills
- Suitable for cavities up to 150mm

Features and Benefits

- Effective DPC and thermal barrier between frame, inner and outer wall leaf
- Thermal conductivity of 0.031W/m²k
- Exceeds the minimum thermal resistance path of 0.45m² K/W stipulated in accredited construction details
- Rigid profile extrusion allows second fix
- Durable and resistant to decay
- Simple on-site trimming to cope with 'rogue' cavity widths
- Global warming potential of less than 5
- Ozone depletion potential of zero
- Available fully rebated - Check reveal (single flange)

Quality

- Manufactured to BS EN ISO 9001 and BS EN ISO 14001
- Complies with Building Regulation Approved Documents C, L1 & L2
- Satisfies BRE document 'Thermal insulation: avoiding risks'
- Meets all relevant British Standards
- Satisfies NHBC standards

Material and Colour Choice

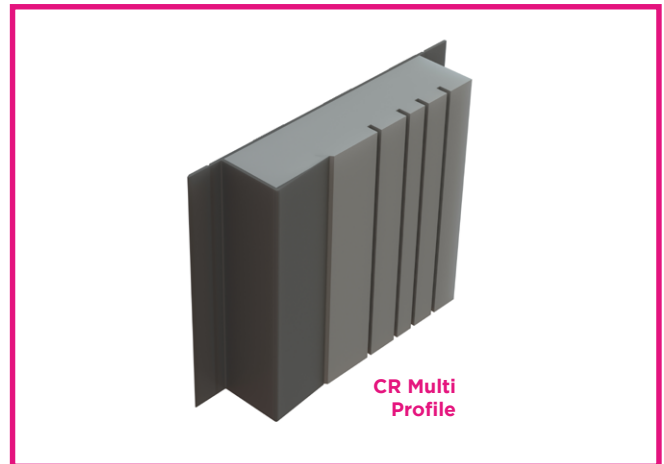
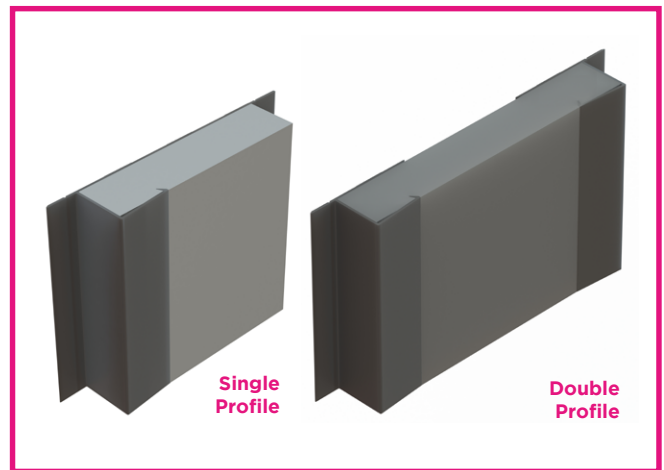
- Rigid profile extruded in Grey UPVC
- Platinum expanded Polystyrene insulation 0.031W/mk
- Multi 100mm, Multi 100mm CR and fixed cavities
- 2.4m lengths

Installation Advice

- The accredited construction detail published by DCLG require a minimum overlap of 30mm between the window frame and cavity closer
- Cut into required lengths allowing jamb section to overlap the sill section by cutting away parts of the fixing flange and to butt the underside of the lintel.
- For second fix applications, the cavity closer is pushed into the open cavity after building work is complete. The compressible nature of the exposed insulation material is used to create a friction fit in the cavity, or alternatively the insulation can be trimmed to fit using a sharp knife
- Fixing nails to the flanges are recommended to ensure a secure fit
- Cavity insulation should butt tightly to the cavity closer

Technical Considerations

- BRE Document 'Thermal insulation: avoiding risks' stipulate "When a window or door frame is set back behind the inner face of a dense outer masonry leaf, it should overlap an insulated closer by a minimum of 30mm for BRE exposure zones Sheltered to Severe; but fully rebated (check reveals) for zones Very Severe"
- With reference to insulation, the products in this range do not use, contain or produce Urea Formaldehyde, CFC's or indeed any of the so called soft CFC's, ie. HCFC's & HFA's. They have an ozone depletion potential of zero and global warming potential of less than 5 and complies with BS EN 13163.



Single Profile | 50mm - 100mm cavities



Double Profile | 105mm - 150mm cavities



Multi | Check Reveal (single flange)



Bill of Quantity

F30 Accessories/sundry items for brick/block/stone walling window jambs and sills

Clause 180 | CAVITY CLOSURES FOR CLOSING AROUND WINDOW & DOOR OPENINGS

- To extend not less than 150mm beyond ends of lintels/bridgings.
- Manufacturer: Timloc Building Products, Ozone Park, Howden, East Yorks. DN14 7SD. T: 01405 765 567 W: www.timloc.co.uk
- Reference: eg.PP2.4/50 (Thermo-loc Platinum Multi, Expanded Polystyrene, 2.4m, 50mm)

Platinum +

Cavity closers for eliminating damp and cold bridging around doors, windows and sills



Scan to view the full product page on the Timloc website

How to Order

- Establish the cavity width and select the correct cavity closer width to ensure the cavity can be closed
- In jamb and sill applications, estimate the total length of cavity closer required and order the correct number of 2.4 metre lengths ensuring no joint pieces

Product Codes

Product Code	Description	Cavity Width	Length	Pack Quantity	Lead Time
PP2.4/50	Thermo-loc Platinum +	50mm	2.4m	10	Next working day
PP2.4/75	Thermo-loc Platinum +	75mm	2.4m	10	Next working day
PP2.4/90	Thermo-loc Platinum +	90mm	2.4m	10	Next working day
PP2.4/100	Thermo-loc Platinum +	100mm	2.4m	10	Next working day
PP2.4/100MULTI	Thermo-loc Platinum + Multi	50-100mm	2.4m	10	Next working day
PP2.4/120	Thermo-loc Platinum +	120mm	2.4m	10	Next working day
PP2.4/125	Thermo-loc Platinum +	125mm	2.4m	10	Next working day
PP2.4/130	Thermo-loc Platinum +	130mm	2.4m	10	Next working day
PP2.4/150	Thermo-loc Platinum +	150mm	2.4m	10	Next working day
PP2.4/CR100MULTI	Thermo-loc Platinum + CR Multi	50-100mm	2.4m	10	3 working days

Platinum + FX

Universal closers for eliminating damp and cold bridging around doors, windows and sills

Use

- To close the cavity at external doors, window jambs and sills
- To provide thermal insulation and prevent 'cold bridging'
- To provide a DPC at external doors, window jambs or sills
- Suitable for cavities up to 150mm

Features and Benefits

- Provides an effective DPC and thermal barrier between frame, inner and outer wall leaf
- Thermal conductivity of 0.031W/mk
- Exceeds the minimum thermal resistance path of 0.45m² K/W stipulated in accredited construction details
- Rigid profile extrusion allows first and second fix
- Durable and resistant to decay
- Simple on-site trimming to cope with 'rogue' cavity widths
- Global warming potential of less than 5
- Ozone depletion potential of zero
- Available fully rebated - Check reveal (single flange)

Quality

- Manufactured to BS EN ISO 9001 and BS EN ISO 14001
- Complies with Building Regulation Approved Documents C, L1 & L2
- Satisfies BRE document 'Thermal insulation: avoiding risks'
- Meets all relevant British Standards
- Satisfies NHBC standards

Material and Colour Choice

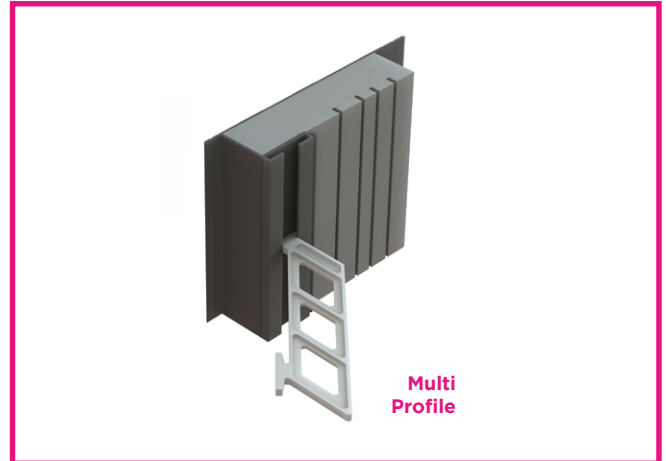
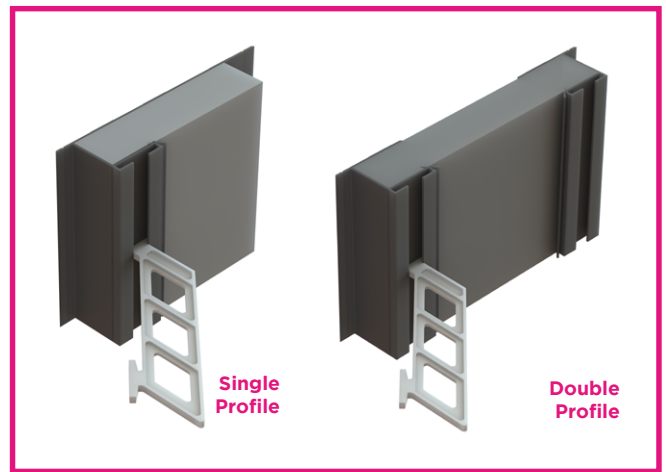
- Rigid profile extruded in Grey UPVC
- Platinum expanded Polystyrene insulation 0.031W/mk
- Multi 100mm, Multi 100mm CR and fixed cavities
- 2.4m lengths

Installation Advice

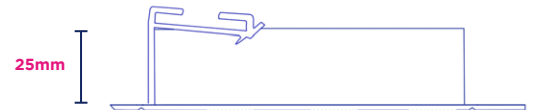
- The accredited construction detail published by DCLG require a minimum overlap of 30mm between the window frame and cavity closer
- Cut the cavity closer into the required lengths allowing the jamb section to overlap the sill section by cutting away parts of the fixing flange and to butt the underside of the lintel
- For second fix applications, the cavity closer is pushed into the open cavity after building work is complete. The compressible nature of the exposed insulation material is used to create a friction fit in the cavity, or alternatively the insulation can be trimmed to fit using a sharp knife
- Fixing nails to the flanges are recommended to ensure a secure fit
- Cavity insulation should butt tightly to the cavity closer

Technical Considerations

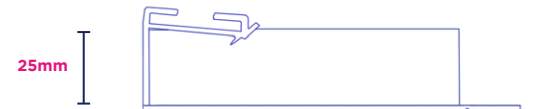
- BRE Document 'Thermal insulation: avoiding risks' stipulate "When a window or door frame is set back behind the inner face of a dense outer masonry leaf, it should overlap an insulated closer by a minimum of 30mm for BRE exposure zones Sheltered to Severe; but fully rebated (check reveals) for zones Very Severe"
- With reference to insulation, the products in this range do not use, contain or produce Urea Formaldehyde, CFC's or indeed any of the so called soft CFC's, ie. HCFC's & HFA's. They have an ozone depletion potential of zero and global warming potential of less than 5 and complies with BS EN 13163.



Single Profile | 50mm - 100mm cavities



Single Profile | Check Reveal (single flange)



Double Profile | 105mm - 150mm cavities



Double Profile | Check Reveal (single flange)



Bill of Quantity

F30 Accessories/sundry items for brick/block/stone walling window jambs and sills

Clause 180 | CAVITY CLOSURES FOR CLOSING AROUND WINDOW & DOOR OPENINGS

- To extend not less than 150mm beyond ends of lintels/bridgings.
- Manufacturer: Timloc Building Products, Ozone Park, Howden, East Yorks. DN14 7SD. T: 01405 765 567 W: www.timloc.co.uk
- Reference: eg.FX2.4/50 (Thermo-loc Platinum+ FX, Expanded Polystyrene, 2.4m, 50mm)

Platinum + FX

Universal closers for eliminating damp and cold bridging around doors, windows and sills



Scan to view the full product page on the Timloc website

How to Order

- Establish the cavity width and select the correct cavity closer width to ensure the cavity can be closed
- In jamb and sill applications, first estimate the total length of cavity closer required, then order the correct number of individual 2.4 metre lengths so no joint pieces

Product Codes

Product Code	Description	Cavity Width	Length	Pack Quantity	Lead Time
FX2.4/50	Thermo-loc Platinum + FX	50mm	2.4m	10	Next working day
FX2.4/75	Thermo-loc Platinum + FX	75mm	2.4m	10	Next working day
FX2.4/90	Thermo-loc Platinum + FX	90mm	2.4m	10	Next working day
FX2.4/100	Thermo-loc Platinum + FX	100mm	2.4m	10	Next working day
FX2.4/120	Thermo-loc Platinum + FX	120mm	2.4m	10	Next working day
FX2.4/125	Thermo-loc Platinum + FX	125mm	2.4m	10	Next working day
FX2.4/130	Thermo-loc Platinum + FX	130mm	2.4m	10	Next working day
FX2.4/150	Thermo-loc Platinum + FX	150mm	2.4m	10	Next working day
FX2.4/100MULTI	Thermo-loc Platinum + FX Multi	50-100mm	2.4m	10	Next working day
FX2.4/CR50	Thermo-loc Platinum + FX CR	50mm	2.4m	10	3 working days
FX2.4/CR100	Thermo-loc Platinum + FX CR	100mm	2.4m	10	3 working days
FX2.4/CR125	Thermo-loc Platinum + FX CR	125mm	2.4m	10	3 working days
FX2.4/CR150	Thermo-loc Platinum + FX CR	150mm	2.4m	10	3 working days
FX2.4/CR100MULTI	Thermo-loc Platinum + FX CR Multi	50-100mm	2.4m	10	3 working days
CCFIX	Fixing ties - 100 pack	-	-	100	Next working day

THERMO-LOC FR30

30-minute fire rated cavity closer

Fire rated barriers for eliminating damp and cold bridging around doors, windows and sills

CAVITY
CLOSERS

Use

- To close the cavity at external doors, window jambs and sills
- To provide thermal insulation and prevent 'cold bridging'
- To provide a DPC at external doors, window jambs or sills
- 30 minutes fire rating and minimum 15 minutes insulation
- Suitable for cavities up to 300mm
- Suitable for masonry walls

Features and Benefits

- Provides an effective DPC and thermal barrier between frame, inner and outer wall leaf
- Thermal conductivity of 0.036W/mK
- Exceeds the minimum thermal resistance path of 0.45m²K/W stipulated in 'Part L' accredited construction details
- Rigid profile extrusion allows both first and second fix
- Suitable for all frame and sill positions (see Fig.1)
- Durable and resistant to decay
- Insulation option to suit your requirements both thermal and fire rated
- Global warming potential of zero
- Ozone depletion potential of zero
- Available fully rebated - Check reveal (single flange)(see Fig. 2)

Quality

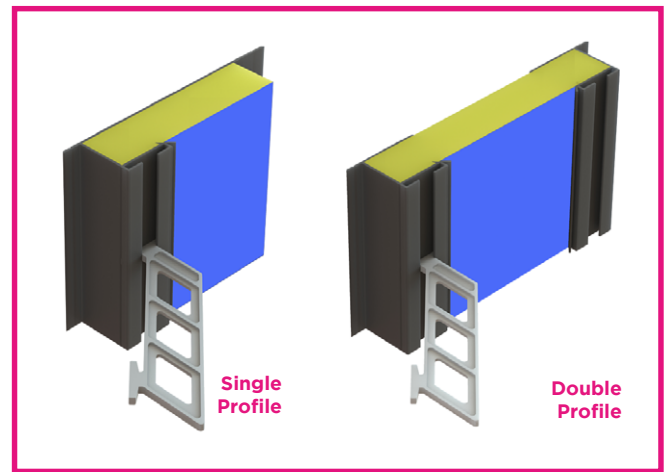
- Independently tested by Warrington Fire
- Satisfies NHBC Standards
- Manufactured to BS EN ISO 9001 and BS EN ISO 14001
- Complies with Building Regulation Approved Documents C, B, L1 & L2
- Complies with 'Part L' accredited construction details
- Complies with the Scottish Building Standards 'Technical handbook'
- Satisfies BRE document 'Thermal insulation: avoiding risks'
- Meets all relevant British Standards

Material and Colour Choice

- Rigid profile extruded in grey UPVC
- Supplied in 2.4 metre lengths
- Standard cavity options available 50mm - 300mm
- Rockfibre mineral wool (FR) insulation 0.036W/mk
- Polyethylene bag encapsulates insulation for moisture protection

Installation Advice

- Can be used in both first and second fix applications
- Cut the cavity closer into required lengths allowing the jamb section to overlap the sill section and to butt the underside of the lintel
- In first fix application the cavity barrier should be nailed to the jamb/sill of the door or window frame and the whole assembly built in as work proceeds. Alternatively the barrier can be built in sections using fixing ties as work proceeds.
- For second fix applications, the cavity closer is pushed into the open cavity after building work is complete. The compressible nature of the exposed insulation material is used to create a friction fit in the cavity, secure nail fixing is required.
- Joining 'off cut' sections should not be carried out for the FR range



Single Profile | 50mm - 100mm cavities

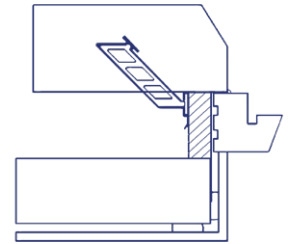
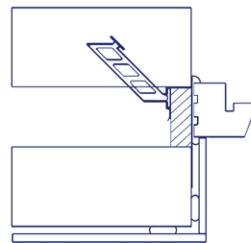


Double Profile | 105mm - 300mm cavities

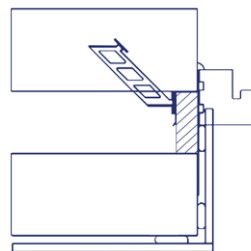


Fig.1 Flush jamb

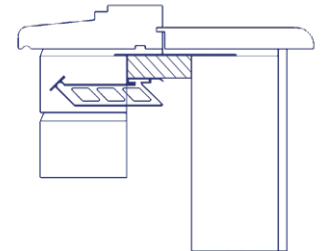
Fig.2 Fully rebated check reveal



Staggered jamb



Sill detail



Bill of Quantity

F30 Accessories/sundry items for brick/block/stone walling
Clause

180 | CAVITY CLOSURES FOR CLOSING AROUND WINDOW & DOOR OPENINGS

- To extend not less than 150mm beyond ends of lintels/bridgings.
- Manufacturer: Timloc Building Products, Timloc House, Ozone Park, Howden, East Yorks. DN14 7SD. T: 01405 765 567, W: www.timloc.co.uk
- Reference: eg. CC2.4FR/75 (Thermo-loc FR30, 2.4m, 75mm cavity)
- Accessories: Fixing ties available, 6 No. per 2.4m cavity barrier.

THERMO-LOC FR30

30-minute fire rated cavity closer

Fire rated barriers for eliminating damp and cold bridging around doors, windows and sills

Technical Considerations

- BRE Document 'Thermal insulation: avoiding risks' and Robust Details stipulate: "When a window or door frame is set back behind the inner face of a dense outer masonry leaf, it should overlap an insulated closer by a minimum of 30mm for BRE exposure zones Sheltered to Severe; but fully rebated (check reveals for zones Very Severe" (see Fig.2)
- With reference to insulation, the products in this range do not use, contain or produce Urea Formaldehyde, CFC's or indeed any of the so called soft CFC's, ie. HCFC's & HFA's. They conform to the Montreal Protocol and have an ozone depletion potential of zero and global warming potential of zero.

How to Order

- Establish the cavity width and select the correct cavity closer width, or the next size up to ensure the cavity can be closed
- In jamb and sill applications, first estimate the total length of cavity barrier required, then order the correct number of individual 2.4 metre lengths so no joint pieces
- Fixing ties are available for secure fixing if required (particular attention around door openings). Allow for ties fitted at 450mm centres

Product Codes

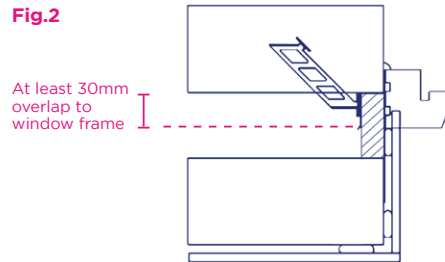
Product Code	Description	Cavity Width	Length	Pack Quantity	Lead Time
CC2.4FR/50	Thermo-loc FR30	50mm	2.4m	10	Next working day
CC2.4FR/65	Thermo-loc FR30	65mm	2.4m	10	Next working day
CC2.4FR/75	Thermo-loc FR30	75mm	2.4m	10	Next working day
CC2.4FR/90	Thermo-loc FR30	90mm	2.4m	10	Next working day
CC2.4FR/100	Thermo-loc FR30	100mm	2.4m	5	Next working day
CC2.4FR/125	Thermo-loc FR30	125mm	2.4m	5	Next working day
CC2.4FR/150	Thermo-loc FR30	150mm	2.4m	3	Next working day
CCFIX	Fixing ties - 100 pack	-	-	100	Next working day

NB. Non standard cavity sizes upto 300mm available to special order

NON STANDARD & SPECIAL LEAD TIMES

- Orders for non standard and special sizes upto 50 pieces received before 12pm - Next working day.
- Orders received after 12pm will be despatched the following working day.
- Orders for non standard and specials sizes over 50 pieces - 3 working days.

Fig.2



Scan to view the full product page on the Timloc website

THERMO-LOC FR60

60-minute fire rated cavity closer

Fire rated barriers for eliminating damp and cold bridging around doors, windows and sills

CAVITY
CLOSERS

Use

- To close the cavity at external doors, window jambs and sills
- To provide thermal insulation and prevent 'cold bridging'
- To provide a DPC at external doors, window jambs or sills
- 60 minutes fire rating and minimum 15 minutes insulation
- Suitable for cavities up to 150mm
- Suitable for masonry walls

Features and Benefits

- Provides an effective DPC and thermal barrier between frame, inner and outer wall leaf
- Thermal conductivity of 0.036W/mK
- Exceeds the minimum thermal resistance path of 0.45m²K/W stipulated in 'Part L' accredited construction details
- Rigid profile extrusion allows both first and second fix
- Suitable for all frame and sill positions (see Fig.1)
- Durable and resistant to decay
- Insulation option to suit your requirements both thermal and fire rated
- Global warming potential of zero
- Ozone depletion potential of zero
- Available fully rebated - Check reveal (single flange) (see Fig.2)

Quality

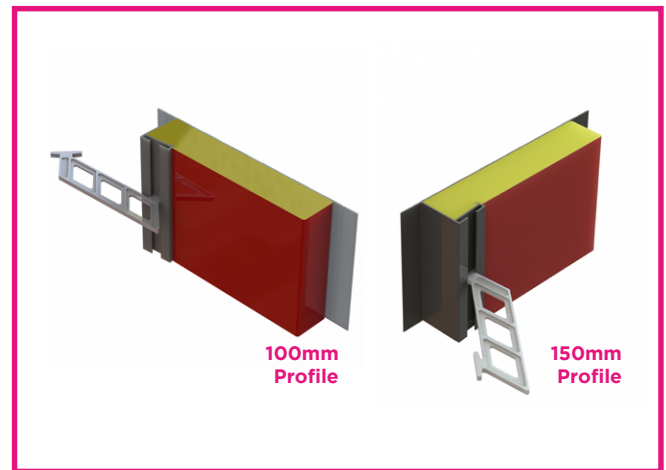
- Independently tested by Warrington Fire
- Satisfies NHBC Standards
- Manufactured to BS EN ISO 9001 and BS EN ISO 14001
- Complies with Building Regulation Approved Documents C, B, L1 & L2
- Complies with 'Part L' accredited construction details
- Complies with the Scottish Building Standards 'Technical handbook'
- Satisfies BRE document 'Thermal insulation: avoiding risks'
- Meets all relevant British Standards

Material and Colour Choice

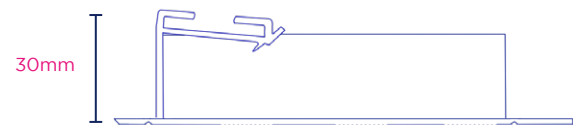
- Rigid profile extruded in grey UPVC
- Supplied in 2.4 metre lengths
- Standard cavity options available 50mm - 150mm
- Rockfibre mineral wool (FR) insulation 0.036W/mk
- Polyethylene bag encapsulates insulation for moisture protection

Installation Advice

- Can be used in both first and second fix applications
- Cut the cavity closer into required lengths allowing the jamb section to overlap the sill section and to butt the underside of the lintel
- In first fix application the cavity barrier should be nailed to the jamb/sill of the door or window frame and the whole assembly built in as work proceeds. Alternatively the barrier can be built in sections using fixing ties as work proceeds.
- For second fix applications, the cavity barrier is pushed into the open cavity after building work is complete. The compressible nature of the exposed insulation material is used to create a friction fit in the cavity, secure nail fixing is required.
- Joining 'off cut' sections should not be carried out for the FR range



Single Profile | 50mm - 100mm cavities



Single Profile | 105mm - 150mm cavities



Fig.1 Flush jamb

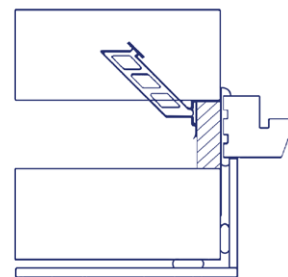
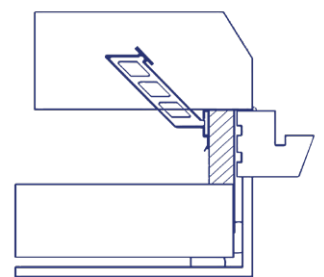
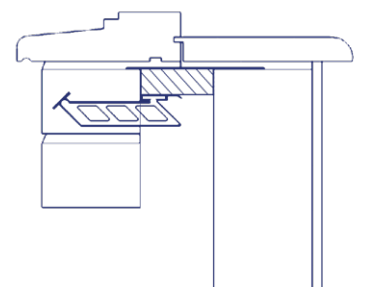


Fig.2 Fully rebated check reveal



Sill detail



Cavity barriers for fully rebated / check reveals also available

Bill of Quantity

F30 Accessories/sundry items for brick/block/stone walling
Clause

180 | CAVITY CLOSURES FOR CLOSING AROUND WINDOW & DOOR OPENINGS

- To extend not less than 150mm beyond ends of lintels/bridgings.
- Manufacturer: Timloc Building Products, Timloc House, Ozone Park, Howden, East Yorks. DN14 7SD. T: 01405 765 567, W: www.timloc.co.uk
- Reference: eg. FR60/50 (Thermo-loc FR60, 2.4m, 50mm cavity)
- Accessories: Fixing ties available, 6 No. per 2.4m cavity barrier.

THERMO-LOC FR60

60-minute fire rated cavity closer

Fire rated barriers for eliminating damp and cold bridging around doors, windows and sills

Technical Considerations

- BRE Document 'Thermal insulation: avoiding risks' and Robust Details stipulate: "When a window or door frame is set back behind the inner face of a dense outer masonry leaf, it should overlap an insulated closer by a minimum of 30mm for BRE exposure zones Sheltered to Severe; but fully rebated (check reveals for zones Very Severe" (see Fig.2)
- With reference to insulation, the products in this range do not use, contain or produce Urea Formaldehyde, CFC's or indeed any of the so called soft CFC's, ie. HCFC's & HFA's. They conform to the Montreal Protocol and have an ozone depletion potential of zero and global warming potential of zero.

How to Order

- Establish the cavity width and select the correct cavity barrier width, or the next size up to ensure the cavity can be closed
- In jamb and sill applications, first estimate the total length of cavity barrier required, then order the correct number of individual 2.4 metre lengths so limiting joint pieces
- Fixing ties are available for secure fixing if required (particular attention around door openings). Allow for ties fitted at 450mm centres

Product Codes

Product Code	Description	Cavity Width	Length	Pack Quantity	Lead Time
FR60/50	Thermo-loc FR60	50mm	2.4m	5	Next working day
FR60/100	Thermo-loc FR60	100mm	2.4m	5	Next working day
FR60/125	Thermo-loc FR60	125mm	2.4m	5	Next working day
FR60/150	Thermo-loc FR60	150mm	2.4m	5	Next working day
FR60/CR50	Thermo-loc FR60 CR	50mm	2.4m	5	3 working days
FR60/CR65	Thermo-loc FR60 CR	65mm	2.4m	5	3 working days
FR60/CR75	Thermo-loc FR60 CR	75mm	2.4m	5	3 working days
FR60/CR90	Thermo-loc FR60 CR	90mm	2.4m	5	3 working days
FR60/CR100	Thermo-loc FR60 CR	100mm	2.4m	5	3 working days
FR60/CR125	Thermo-loc FR60 CR	125mm	2.4m	5	3 working days
FR60/CR150	Thermo-loc FR60 CR	150mm	2.4m	5	3 working days
CCFIX	Fixing ties - 100 pack	-	-	100	Next working day

NB. Non standard cavity sizes upto 300mm available to special order

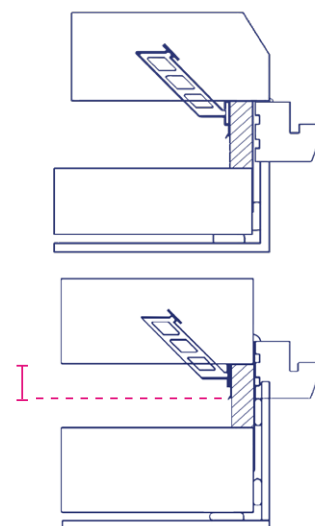
NON STANDARD & SPECIAL LEAD TIMES

- Orders for non standard and special sizes upto 50 pieces received before 12pm - Next working day.
- Orders received after 12pm will be despatched the following working day.
- Orders for non standard and specials sizes over 50 pieces - 3 working days.

Fig. 2
Fully rebated (check reveal)

Staggered jamb

At least 30mm overlap to window frame



Scan to view the full product page on the Timloc website

THERMO-LOC FR60+

60-minute fire rated cavity closer

Fire rated barriers for eliminating damp and cold bridging around doors, windows and sills for cavities over 150mm up to 300mm

CAVITY
CLOSERS

Use

- To close the cavity at external doors, window jambs and sills
- To provide thermal insulation and prevent 'cold bridging'
- To provide a DPC at external doors, window jambs or sills
- 60 minutes fire rating and minimum 15 minutes insulation
- Suitable for cavities over 150mm up to 300mm
- Suitable for masonry walls

Features and Benefits

- Provides an effective DPC and thermal barrier between frame, inner and outer wall leaf
- Thermal conductivity of 0.034W/mK
- Exceeds the minimum thermal resistance path of 0.45m²K/W stipulated in 'Part L' accredited construction details
- Rigid profile extrusion allows both first and second fix
- Suitable for flush jambs and sill positions (see Fig.1)
- Durable and resistant to decay
- Insulation option to suit your requirements both thermal and fire rated
- Global warming potential of zero
- Ozone depletion potential of zero

Quality

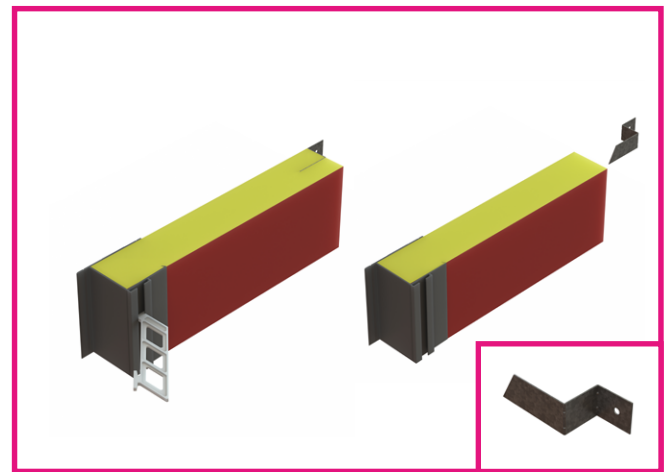
- Independently tested by Warrington Fire
- Satisfies NHBC Standards
- Manufactured to BS EN ISO 9001 and BS EN ISO 14001
- Complies with Building Regulation Approved Documents C, B, L1 & L2
- Complies with 'Part L' accredited construction details
- Complies with the Scottish Building Standards 'Technical handbook'
- Satisfies BRE document 'Thermal insulation: avoiding risks'
- Meets all relevant British Standards

Material and Colour Choice

- Rigid profile extruded in grey UPVC
- Supplied in 2.4 metre lengths
- 50mm Rockfibre mineral wool (FR) insulation 0.034W/m²K
- Polyethylene bag encapsulates insulation for moisture protection

Installation Advice

- Can be used in both first and second fix applications
- Cut the cavity closer into required lengths allowing the jamb section to overlap the sill section and to butt the underside of the lintel
- Fit the 4 metal fixing flanges 100mm from each end and 100mm from the centre line. Ensure 2 fixing flanges per insulation slab section.
- In first fix application the cavity barrier should be nailed to the jamb/sill of the door or window frame and the whole assembly built in as work proceeds. Alternatively the barrier can be built in sections using fixing ties as work proceeds.
- For second fix applications, the cavity barrier is pushed into the open cavity after building work is complete. The compressible nature of the exposed insulation material is used to create a friction fit in the cavity, secure nail fixing is required.
- Joining 'off cut' sections should be minimised for the FR range.



FR60+ Profile | 150mm - 300mm cavities



FR60+ fixing flanges installation

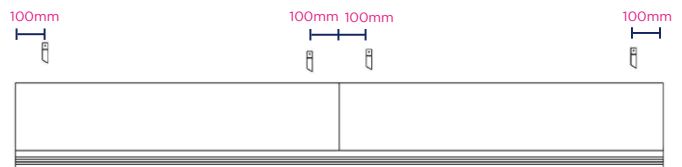
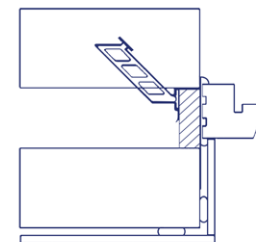
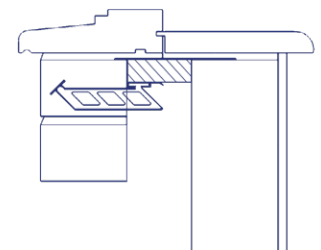


Fig.1 Flush jamb

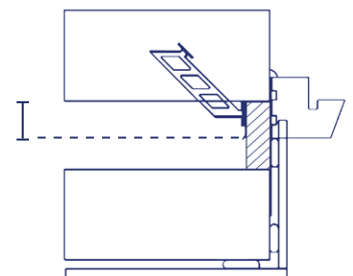


Sill detail



Staggered jamb

At least 30mm overlap to window frame



Bill of Quantity

F30 Accessories/sundry items for brick/block/stone walling
Clause

180 | CAVITY CLOSURES FOR CLOSING AROUND WINDOW & DOOR OPENINGS

- Manufacturer: Timloc Building Products, Timloc House, Ozone Park, Howden, East Yorks. DN14 7SD. T: 01405 765 567, W: www.timloc.co.uk
- Reference: eg. FR60/200 (Thermo-loc FR60+, 2.4m, 200mm cavity)
- Accessories: Fixing ties available, 6 No. per 2.4m cavity barrier.

THERMO-LOC FR60+

60-minute fire rated cavity closer

Fire rated barriers for eliminating damp and cold bridging around doors, windows and sills for cavities over 150mm up to 300mm

Technical Considerations

- BRE Document 'Thermal insulation: avoiding risks' and Robust Details stipulate: "When a window or door frame is set back behind the inner face of a dense outer masonry leaf, it should overlap an insulated closer by a minimum of 30mm for BRE exposure zones Sheltered to Severe; but fully rebated check reveals for zones Very Severe".
- With reference to insulation, the products in this range do not use, contain or produce Urea Formaldehyde, CFC's or indeed any of the so called soft CFC's, ie. HCFC's & HFA's. They conform to the Montreal Protocol and have an ozone depletion potential of zero and global warming potential of zero.

How to Order

- Establish the cavity width and select the correct cavity barrier width, or the next size up to ensure the cavity can be closed
- In jamb and sill applications, first estimate the total length of cavity barrier required, then order the correct number of individual 2.4 metre lengths so limiting joint pieces
- Fixing ties are available for secure fixing if required (particular attention around door openings). Allow for ties fitted at 450mm centres
- Supplied with 4 metal fixing flanges that must be slotted into place.

Product Codes

Product Code	Description	Cavity Width	Length	Pack Quantity	Lead Time
FR60/175	Thermo-loc FR60+	175mm	2.4m	2	Variable (see below)
FR60/200	Thermo-loc FR60+	200mm	2.4m	2	Variable (see below)
FR60/225	Thermo-loc FR60+	225mm	2.4m	2	Variable (see below)
FR60/250	Thermo-loc FR60+	250mm	2.4m	2	Variable (see below)
FR60/275	Thermo-loc FR60+	275mm	2.4m	2	Variable (see below)
FR60/300	Thermo-loc FR60+	300mm	2.4m	2	Variable (see below)
CCFIX	Fixing ties - 100 pack	-	-	100	Next working day

**NB. Non standard cavity sizes upto 300mm available to special order
Not available as fully rebated or check reveal options**

NON STANDARD & SPECIAL LEAD TIMES

- Orders for upto 50 pieces received before 12pm - Next working day.
- Orders received after 12pm will be despatched the following working day.
- Orders for over 50 pieces - 3 working days.



Scan to view the full product page on the Timloc website

FRSTOP

Fire-Rated Cavity Stop Sock

Fire-rated thermal and acoustic cavity stop sock

Use

- To restrict the spread of flames within external masonry
- To further minimise the effect of flanking noise pollution at wall junctions

Features and Benefits

- FRstop cavity stop socks are lengths of low resin, non-combustible, rockfibre mineral wool sleeved in 35 micron polythene for on-site weather protection
- 1 hour fire integrity and minimum 15 minute insulation
- Available in standard widths of 50, 75, 85, 90, 100, 115, 125 and 150mm
- Also available to suit cavity widths of up to 300mm
- Special cavity widths are available on request up to 300mm

Quality

- Satisfies all NHBC requirements
- Complies with Building Regulations Approved Document B
- Meets all relevant British Standards
- Independently tested by Warrington Fire
- Meets the requirements of the Robust Details

Material and Colour Choice

- Manufactured using Rockfibre mineral wool
- Rockfibre uses no CFC's, HCFC's in the manufacturing process
- Thermal conductivity of Rockfibre insulation 0.037w/mK
- Bag colour according to size range:

Product Code	Bag Colour
FRSTOP50	Yellow ●
FRSTOP65 - 100	Blue ●
FRSTOP115 - 140	Green ●
FRSTOP150 - 200	Red ●
FRSTOP210 - 300	Blue ●

Installation Advice

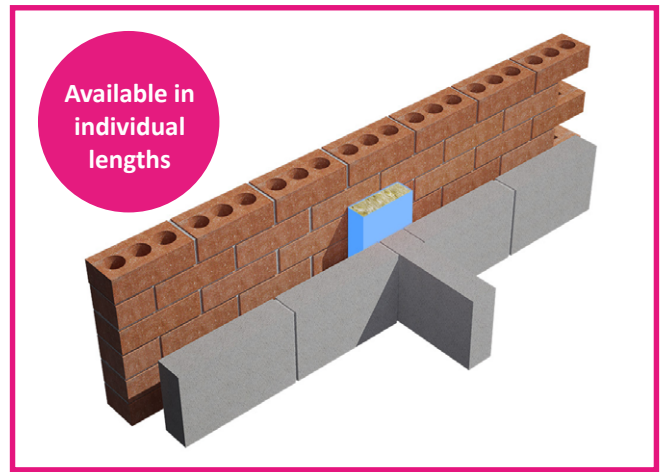
- FRstop is designed to friction fit within the cavity and is easily installed both vertically and horizontally into the cavity during construction. Care should be taken to ensure butt joints are closely fitted and the cavity sock fully fills the cavity.
- This method should be incorporated with a preformed horizontal cavity tray (refer to Technical Department for appropriate type) and proprietary wall weep vents (1143) at 900mm centres to prevent water ingress from bridging the cavity.

How to Order

- To calculate quantities divide the overall length of the required cavity wall run by 1.2m, allow an additional unit for each corner for cutting.
- Always round up to the next whole number
- Determine and stipulate the cavity width that FRstop needs to suit

Product Codes

Product Code	To Suit Cavity Width	Bag Colour	Dimensions	Pack Quantity	Lead Time
FRSTOP50	50mm	Yellow	65 x 65 x 1200mm	20	Next working day
FRSTOP75	75mm	Blue	85 x 85 x 1200mm	18	Next working day
FRSTOP85	85mm	Blue	100 x 85 x 1200mm	1	Next working day
FRSTOP90	90mm	Blue	100 x 85 x 1200mm	1	Next working day
FRSTOP100	100mm	Blue	110 x 100 x 1200mm	1	Next working day
FRSTOP115	115mm	Green	130 x 100 x 1200mm	1	Next working day
FRSTOP125	125mm	Green	140 x 100 x 1200mm	1	Next working day
FRSTOP150	150mm	Red	160 x 120 x 1200mm	1	Next working day



Bill of Quantity

F30 Accessories/sundry items for brick/block/stone walling Clause

370 PREFORMED CAVITY TRAY / ACCESSORIES

- Manufacturer: Timloc Building Products, Timloc House, Ozone Park, Howden, East Yorks. DN14 7SD. T: 01405 765 567 W: www.timloc.co.uk
- Types(s) and location(s): FRstop - thermal and acoustic fire stops to be installed vertically and horizontally as work proceeds. Position where a party wall meets the cavity wall or at floor levels, supplied in 1.2m lengths and butt jointed.
- Reference: FRstop



Scan to view the full product page on the Timloc website

NB. Non standard cavity sizes up to 300mm are available to special order



ACCESS PRODUCTS

Product	Page No.
1168 Plastic Push-up Loft Door	62
1169 Plastic Hinged Drop Down Loft Access Door	63
Z-Series Metal 1-hour Fire Rated Hinged Loft Access Door - Full Range	64
Z-Series Metal 1-hour Fire Rated Hinged Loft Access Door - 1160 & 1161	66
Loft-loc Loft Door Operating Poles	68
Plastic & Metal Loft Doors - Technical Information & Installation Advice	69
Plastic Access Panels	70
Airtight Plastic Access Panels	71
Z-Series Metal Access Panels	72
Metal 1-Hour Fire Rated Access Panels	73

SCAN
TO VIEW



**CATEGORY
GUIDE**

AVAILABLE



1168 Plastic Push-up Loft Access Door

Easy to install for loft access

Use

- To provide simple, easy access through ceiling into the loft space

Features and Benefits

- Purpose made product saves time and money compared with traditional joiner-made timber loft access doors
- Standard and higher U value insulation performances available
- Excellent aesthetic appearance
- Factory finished and ready to fit straight from the box
- Insulated door panel
- Incorporates integral draught/vapour seal
- Incorporates two twist operated catches to secure the door panel and prevent uplift
- Maintenance free, no need to paint
- Acoustic performance of 30dB

Quality

- Satisfies all NHBC requirements
- Manufactured to BS EN ISO 9001 and BS EN ISO 14001
- Complies with Building Reg. document L1A & L2A (2013 Edition)
- Meets all relevant British Standards

Material and Colour Choice

- The frame is a one piece injection moulding in polypropylene
- The door panel is a one piece injection moulding in polypropylene
- Insulation is CFC free expanded polystyrene foam
- Door and frame available in white only RAL 9010

Installation Advice

- The product is designed to fit between 38mm thick trussed rafters or ceiling joists spaced at 600mm centres which provide a clear joist opening width of 562mm
- If the roof design does not provide this joist opening width, a suitable opening must be formed
- Trimmers must be installed across the ends of the frame. These should be spaced to give a clear opening length of 665mm
- Frame fixes with ten screws, three through each side & two through each end
- Fit the loft access door after the ceiling has been plaster boarded & skimmed
- The frame must be a good fit into the trimmed opening. Never force it into an opening that is too small. If the opening is too large use packers to ensure a good fit
- See P.69 for further Technical information

Bill of Quantity

L20 Doors/Shutters/Hatches
Clause

360^ | HATCHES

- Manufacturer: Timloc Building Products, Timloc House, Ozone Park, Howden, East Yorkshire, DN14 7SD. T: 01405 765567, W: www.timloc.co.uk
- Type: Push-up Loft Door 562mm x 662mm joist opening
- Specification: Insulated and draught stripped
- Colour: Textured white Polypropylene

Product Codes

Description	Frame Fitting Size	Clear Opening Size	Insulation U-value	Product Codes
1168 Plastic Push-Up Loft Access Door - 0.82 U-value	562 x 665mm	526 x 626mm	0.82 W/m ² K	1168
1168 Plastic Push-Up Loft Access Door - 0.35 U-value	562 x 665mm	526 x 626mm	0.35 W/m ² K	1168/35
1168 Plastic Push-Up Loft Access Door - 0.25 U-value	562 x 665mm	526 x 626mm	0.25 W/m ² K	1168/25



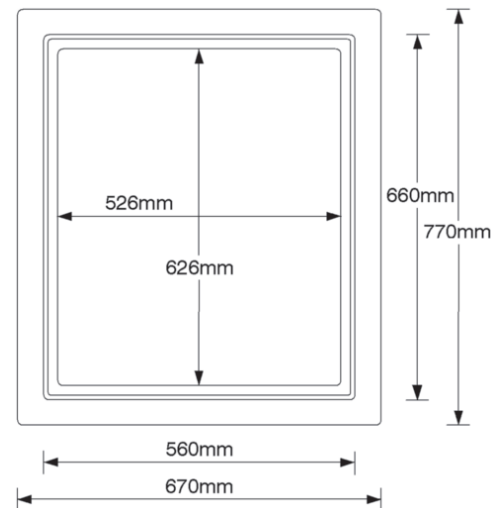
Technical Considerations

- Timloc loft doors comply with Building Regulations; 'THE BUILDING REGULATIONS 'Conservation of fuel and power' APPROVED DOCUMENT L1A & L2A (2013 Edition)
- The Timloc loft access door demonstrates full compliance with the Building Regulation Part L1A & L2A while fully complying with BS5250:2021 the Code of Practice for control of condensation in buildings
- Timloc loft access doors contain polystyrene insulation with a Thermal Conductivity of 0.038W/mK. For this reason a correction U value of 0.004W/m²k should be calculated to the proposed U value figures for a ceiling
- With reference to insulation, the products in this range do not use, contain or produce Urea Formaldehyde, CFC's or indeed any of the so called soft CFC's, ie. HCFC's & HFA's. They have an ozone depletion potential of zero and Global Warming Potential of less than 5

LOFT - LOC Loft door operating poles available P. 68

Replacement parts available P. 185

Product Dimensions



Scan to view the full product page on the Timloc website

1169 Plastic Hinged Drop Down Loft Access Door

Hinged loft doors with lockable options

Use

- To provide simple, easy access through a ceiling into the loft space

Features and Benefits

- Air permeability measured at 50Pa as 0.00m³ (h.m²) under positive pressure test conditions
- Purpose made product saves time and money compared with traditional joiner-made timber loft access doors
- Independently air leakage tested by BRE
- Excellent aesthetic appearance
- Factory finished and ready to fit straight from the box
- Insulated door panel with integral draught/vapour seal
- Maintenance free, no need to paint
- Hinged design allows use of a telescopic loft ladder
- Acoustic performance of 30dB
- Secure key operated lock option available

Quality

- Satisfies all NHBC requirements
- Manufactured to BS EN ISO 9001 and BS EN ISO 14001
- Complies with Building Reg. document L1A & L2A (2013 Edition)
- Meets all relevant British Standards

Material and Colour Choice

- The door and frame are one piece injection moulded polypropylene
- Insulation is CFC free expanded polystyrene foam
- Door and frame available in white only RAL 9010

Installation Advice

- This product is designed to fit between 38mm thick trussed rafters or ceiling joists spaced at 600mm centres to provide a clear joist opening width of 562mm
- If the roof design does not provide this joist opening width, a suitable opening must be formed
- Trimmers must be installed across the ends of the frame. These must be spaced to give a clear opening length of 662mm
- Frame fixes with ten screws, three through each side and two through each end
- Fit the loft access door after the ceiling has been plaster boarded and skimmed
- The frame must be a good fit into the trimmed opening. Never try to force it into an opening that is too small. If the opening is too large use packers to ensure a good fit
- See P.69 for further Technical information

Scan to view the full product page on the Timloc website



Product Codes

Description	Frame Fitting Size	Clear Opening Size	Insulation U-value	Product Codes
1169 Plastic Hinged Drop Down Loft Access Door	562 x 662mm	526 x 626mm	0.82 W/m ² K	1169
1169 Plastic Hinged Drop Down Loft Access Door with Key Lock	562 x 662mm	526 x 626mm	0.82 W/m ² K	1169KL
1169 Plastic Hinged Drop Down Loft Access Door - 0.35 U-value	562 x 662mm	526 x 626mm	0.35 W/m ² K	1169/35
1169 Plastic Hinged Drop Down Loft Access Door with Key Lock - 0.35 U-value	562 x 662mm	526 x 626mm	0.35 W/m ² K	1169/35KL
1169 Plastic Hinged Drop Down Loft Access Door - 0.25 U-value	562 x 662mm	526 x 626mm	0.25 W/m ² K	1169/25
1169 Plastic Hinged Drop Down Loft Access Door with Key Lock - 0.25 U-value	562 x 662mm	526 x 626mm	0.25 W/m ² K	1169/25KL



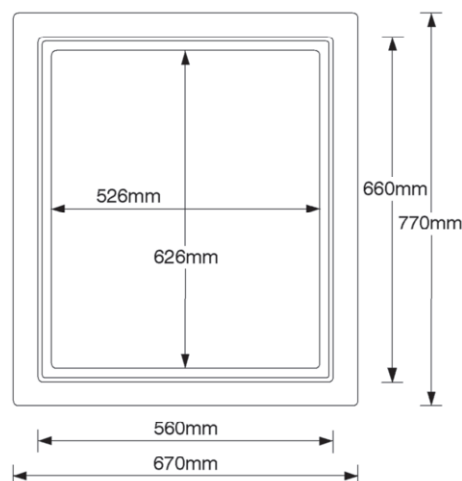
Technical Considerations

- Timloc loft access doors comply with Building Regulations; 'THE BUILDING REGULATIONS 'Conservation of fuel and power' APPROVED DOCUMENT L1A & L2A (2013 Edition)
- Timloc loft access doors comply with the most recent Building Regulations; 'THE BUILDING REGULATIONS 2000 'Conservation of fuel and power' APPROVED DOCUMENT L1A & L2A (2006 Edition)
- The Timloc loft access door has demonstrated a zero 0.00m³/(h.m²) air leakage at 'positive' 50Pa to exceed requirements set in the Building Regulation Part L1A & L2A while fully complying with BS5250:2021 the Code of Practice for control of condensation in buildings
- Timloc loft access doors contain polystyrene insulation with a Thermal Conductivity of 0.038W/mK. For this reason a correction U value of 0.004W/m²k should be calculated to the proposed U value figures for a ceiling (U value for a ceiling not to exceed 0.16W/m²k)
- With reference to insulation, the products in this range do not use, contain or produce Urea Formaldehyde, CFC's or indeed any of the so called soft CFC's, ie. HCFC's & HFA's. They have an ozone depletion potential of zero and Global Warming Potential of less than 5

LOFT - LOC Loft door operating poles available P. 68

Replacement parts available P. 185

Product Dimensions



Z-SERIES

Metal 1 Hour Fire Rated Hinged Loft Access Doors - Full Range

High performance metal loft access doors with 1 hour fire protection

Use

- To provide access through the ceiling into the ceiling void in situations where fire protection is required

Features and Benefits

- Purpose made product with proven performance
- Superior to site fabricated panels
- Provides up to 60 minutes fire protection
- Excellent aesthetic appearance and factory finished
- Maintenance free, no need to paint
- Allows the use of a telescopic ladder if required
- Incorporates secure twist operated catch assembly
- Acoustic performance of 29dB
- U value 0.82 W/m²K and 0.35W/m²K options available
- Budget lock and key lock options available
- All loft doors are hinged on the short side except the 900 x 600mm and 1200 x 600mm sizes which are hinged on the long side

Quality

- Independently fire tested
- Complies with Building Regulations document L1A & L2A (2013 Edition)
- Meets all relevant British Standards and NHBC requirements

Material and Colour Choice

- Frame & door fabricated in 1mm & 1.2mm Zintec electro-galvanised mild steel
- The door is lined with a fire resistant sub-panel to enhance fire resistance and stability
- Polyester powder coating, lightly textured
- Door and frame available in white only RAL 9010

Installation Advice

- The Z8003 and Z8004 are designed to fit between trussed rafters or ceiling joints spaced at 600mm centres which provide a clear joist opening width of 562mm to be plasterboard lined to give 542mm
- If the joist spacing does not provide this opening width, a suitable trimmed opening must be formed
- It is essential that trimmers are installed between the ceiling joists across the ends of the frame
- The frame fixes with screws into the ceiling joists at the sides of the frame and through the ends of the frame into the trimmers
- If timber is used to trim the structural opening, then a layer of plasterboard or other proprietary material must be used to protect the timber.

Technical Considerations

- Timloc loft access doors contain glass wool insulation with a Thermal Conductivity of 0.037W/mK. For this reason a correction. U value of 0.004W/m²K should be calculated to the proposed U value figures for a ceiling (U value for a ceiling, not to exceed 0.16W/m²k)
- With reference to insulation, the products in this range do not use, contain or produce CFC's, ie. HCFC's & HFA's. The mineral wool insulation relies on entrapped air for its thermal properties; air is not a VOC and it does not have Global Warming Potential (GWP) or Ozone Depletion Potential (ODP).



Z-Series Metal Fire Rated Loft Door



Budget Lock



Key Lock

Bill of Quantity

L20 Doors/Shutters/Hatches

Clause

630^A | HATCHES

• Manufacturer: Timloc Building Products, Timloc House, Ozone Park, Howden, East Yorkshire, DN14 7SD. T: 01405 765567 W: www.timloc.co.uk

• Product reference: Example Z8003

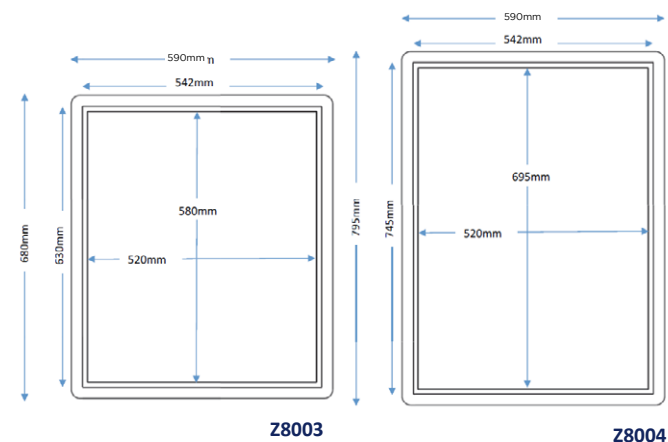
• Type: Z-Series Metal 1 Hour Fire Rated Hinged Loft Access Door

• Z8003 to suit fitting 542mm x 630mm

• Specification: insulated and draught stripped

• Colour: textured white polyester powder coating - RAL 9010

Product Dimensions



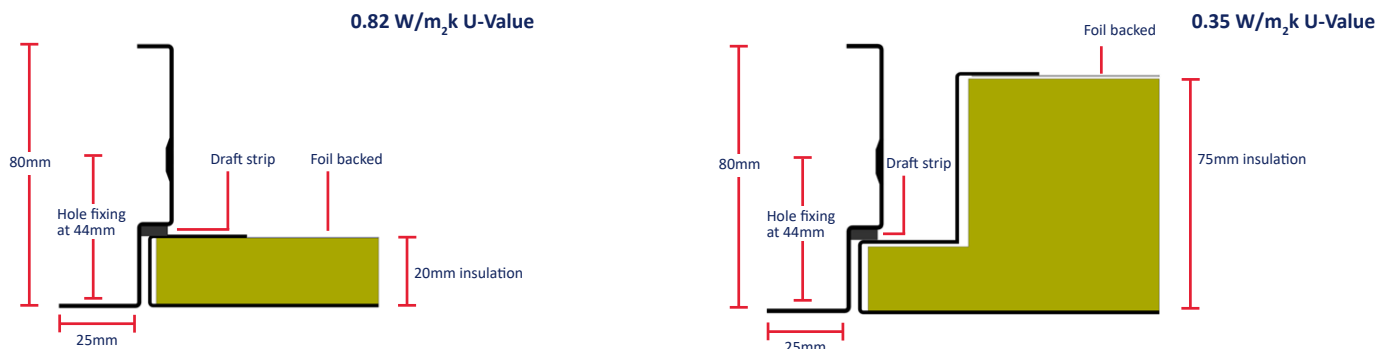
Z8003

Z8004



Scan to view the full product page on the Timloc website

Cross Sections



Product Codes

Metal 1 Hour Rated Hinged Loft Access Doors

Description	Frame Fitting Size	Clear Opening Size	Overall Panel & Frame Size	Insulation U-value	Product Codes
Z-Series Fire Rated Metal Loft Door 550x550mm	555 x 555mm	528 x 500mm	598 x 598mm	0.82 W/m²K	Z8001
Z-Series Fire Rated Metal Loft Door 555x800mm	560 x 805mm	533 x 750mm	603 x 848mm	0.82 W/m²K	Z8002
Z-Series Fire Rated Metal Loft Door 542x630mm	542 x 630mm	520 x 580mm	590 x 680mm	0.82 W/m²K	Z8003
Z-Series Fire Rated Metal Loft Door 542x745mm	542 x 745mm	520 x 695mm	590 x 795mm	0.82 W/m²K	Z8004
Z-Series Fire Rated Metal Loft Door 600x600mm	605 x 605mm	578 x 550mm	648 x 648mm	0.82 W/m²K	Z8005
Z-Series Fire Rated Metal Loft Door 600x900mm	605 x 905mm	578 x 850mm	648 x 948mm	0.82 W/m²K	Z8006
Z-Series Fire Rated Metal Loft Door 900x600mm*	905 x 605mm	850 x 578mm	948 x 648mm	0.82 W/m²K	Z8007
Z-Series Fire Rated Metal Loft Door 1200x600mm*	1205 x 605mm	1178 x 550mm	1248 x 648mm	0.82 W/m²K	Z8008

Metal 1 Hour Fire Rated Hinged Loft Access Doors - Key Lock

Description	Frame Fitting Size	Clear Opening Size	Overall Panel & Frame Size	Insulation U-value	Product Codes
Z-Series Fire Rated Metal Loft Door 550x550mm - Key Lock	555 x 555mm	528 x 500mm	598 x 598mm	0.82 W/m²K	ZKL8001
Z-Series Fire Rated Metal Loft Door 555x800mm - Key Lock	560 x 805mm	533 x 750mm	603 x 848mm	0.82 W/m²K	ZKL8002
Z-Series Fire Rated Metal Loft Door 542x630mm - Key Lock	542 x 630mm	520 x 580mm	590 x 680mm	0.82 W/m²K	ZKL8003
Z-Series Fire Rated Metal Loft Door 542x745mm - Key Lock	542 x 745mm	520 x 695mm	590 x 795mm	0.82 W/m²K	ZKL8004
Z-Series Fire Rated Metal Loft Door 600x600mm - Key Lock	605 x 605mm	578 x 550mm	648 x 648mm	0.82 W/m²K	ZKL8005
Z-Series Fire Rated Metal Loft Door 600x900mm - Key Lock	605 x 905mm	578 x 850mm	648 x 948mm	0.82 W/m²K	ZKL8006
Z-Series Fire Rated Metal Loft Door 900x600mm - Key Lock*	905 x 605mm	850 x 578mm	948 x 648mm	0.82 W/m²K	ZKL8007
Z-Series Fire Rated Metal Loft Door 1200x600mm - Key Lock*	1205 x 605mm	1178 x 550mm	1248 x 648mm	0.82 W/m²K	ZKL8008

Metal 1 Hour Fire Rated Hinged Loft Access Doors - 0.35 U-Value

Description	Frame Fitting Size	Clear Opening Size	Overall Panel & Frame Size	Insulation U-value	Product Codes
Z-Series Fire Rated Metal Loft Door 550x550mm - 0.35 U-Value	555 x 555mm	528 x 500mm	598 x 598mm	0.35 W/m²K	Z9001
Z-Series Fire Rated Metal Loft Door 555x800mm - 0.35 U-Value	560 x 805mm	533 x 750mm	603 x 848mm	0.35 W/m²K	Z9002
Z-Series Fire Rated Metal Loft Door 542x630mm - 0.35 U-Value	542 x 630mm	520 x 580mm	590 x 680mm	0.35 W/m²K	Z9003
Z-Series Fire Rated Metal Loft Door 542x745mm - 0.35 U-Value	542 x 745mm	520 x 695mm	590 x 795mm	0.35 W/m²K	Z9004
Z-Series Fire Rated Metal Loft Door 600x600mm - 0.35 U-Value	605 x 605mm	578 x 550mm	648 x 648mm	0.35 W/m²K	Z9005
Z-Series Fire Rated Metal Loft Door 600x900mm - 0.35 U-Value	605 x 905mm	578 x 850mm	648 x 948mm	0.35 W/m²K	Z9006
Z-Series Fire Rated Metal Loft Door 900x600mm - 0.35 U-Value*	905 x 605mm	850 x 578mm	948 x 648mm	0.35 W/m²K	Z9007
Z-Series Fire Rated Metal Loft Door 1200x600mm - 0.35 U-Value*	1205 x 605mm	1178 x 550mm	1248 x 648mm	0.35 W/m²K	Z9008

Metal 1 Hour Fire Rated Hinged Loft Access Doors - 0.35 U-Value Key Lock

Description	Frame Fitting Size	Clear Opening Size	Overall Panel & Frame Size	Insulation U-value	Product Codes
Z-Series Fire Rated Metal Loft Door 550x550mm - 0.35 U-Value Key Lock	555 x 555mm	528 x 500mm	598 x 598mm	0.35 W/m²K	ZKL9001
Z-Series Fire Rated Metal Loft Door 555x800mm - 0.35 U-Value Key Lock	560 x 805mm	533 x 750mm	603 x 848mm	0.35 W/m²K	ZKL9002
Z-Series Fire Rated Metal Loft Door 542x630mm - 0.35 U-Value Key Lock	542 x 630mm	520 x 580mm	590 x 680mm	0.35 W/m²K	ZKL9003
Z-Series Fire Rated Metal Loft Door 542x745mm - 0.35 U-Value Key Lock	542 x 745mm	520 x 695mm	590 x 795mm	0.35 W/m²K	ZKL9004
Z-Series Fire Rated Metal Loft Door 600x600mm - 0.35 U-Value Key Lock	605 x 605mm	578 x 550mm	648 x 648mm	0.35 W/m²K	ZKL9005
Z-Series Fire Rated Metal Loft Door 600x900mm - 0.35 U-Value Key Lock	605 x 905mm	578 x 850mm	648 x 948mm	0.35 W/m²K	ZKL9006
Z-Series Fire Rated Metal Loft Door 900x600mm - 0.35 U-Value Key Lock*	905 x 605mm	850 x 578mm	948 x 648mm	0.35 W/m²K	ZKL9007
Z-Series Fire Rated Metal Loft Door 1200x600mm - 0.35 U-Value Key Lock*	1205 x 605mm	1178 x 550mm	1248 x 648mm	0.35 W/m²K	ZKL9008

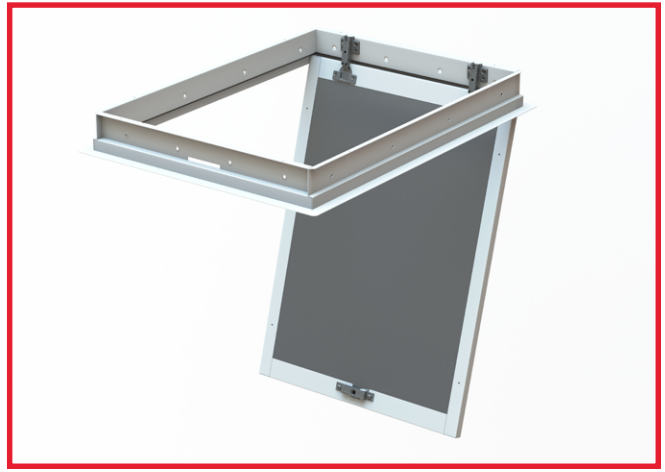
* Hinged on long side

Z-SERIES

Metal 1 Hour Fire Rated Hinged Loft Access Doors

(Previously known as 1160 & 1161)

High performance metal loft access doors with 1 hour fire protection



Z-Series Metal Fire Rated Loft Door - Z8004

Use

- To provide access through the ceiling into the ceiling void in situations where fire protection is required

Features and Benefits

- Compliant with NHBC standards for minimum access opening of 520mm
- Purpose made product with proven performance
- Superior to site fabricated panels
- Provides up to 60 minutes fire protection
- Excellent aesthetic appearance and factory finished
- Maintenance free, no need to paint
- Allows the use of a telescopic ladder if required
- Incorporates secure twist operated catch assembly
- Acoustic performance of 29dB
- U value 0.82 W/m²K and 0.35W/m²K options available
- Budget lock and key lock options available

Quality

- Independently fire tested
- Complies with Building Regulations document L1A & L2A (2013 Edition)
- Meets all relevant British Standards and NHBC requirements

Material and Colour Choice

- The frame and door are fabricated in 1mm and 1.2mm Zintec electro-galvanised mild steel
- The door is lined with a fire resistant sub-panel to enhance fire resistance and stability
- Polyester powder coating, lightly textured
- Door and frame available in white only RAL 9010

Installation Advice

- The Z8003 and Z8004 are designed to fit between trussed rafters or ceiling joists spaced at 600mm centres which provide a clear joist opening width of 562mm to be plasterboard lined to give 542mm
- If the joist spacing does not provide this opening width, a suitable trimmed opening must be formed
- It is essential that trimmers are installed between the ceiling joists across the ends of the frame
- The frame fixes with screws into the ceiling joists at the sides of the frame, and through the ends of the frame into the trimmers
- If timber is used to trim the structural opening, then a layer of plasterboard or other proprietary material must be used to protect the timber.

Technical Considerations

- Timloc loft access doors contain glass wool insulation with a Thermal Conductivity of 0.037W/mK. For this reason a correction. U value of 0.004W/m²K should be calculated to the proposed U value figures for a ceiling (U value for a ceiling, not to exceed 0.16W/m²K)
- With reference to insulation, the products in this range do not use, contain or produce CFC's, ie. HCFC's & HFA's. The mineral wool insulation relies on entrapped air for its thermal properties; air is not a VOC and it does not have Global Warming Potential (GWP) or Ozone Depletion Potential (ODP).



Budget Lock



Key Lock

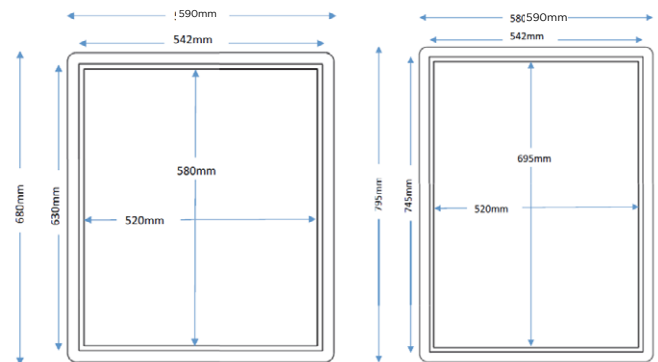
Bill of Quantity

L20 Doors/Shutters/Hatches
Clause

630^A | HATCHES

- Manufacturer: Timloc Building Products, Timloc House, Ozone Park, Howden, East Yorkshire, DN14 7SD. T: 01405 765567 W: www.timloc.co.uk
- Product reference: Example Z8003
- Type: Z-Series Metal 1 Hour Fire Rated Hinged Loft Access Door
- Z8003 to suit fitting 542mm x 630mm
- Specification: insulated and draught stripped
- Colour: textured white polyester powder coating - RAL 9010

Product Dimensions



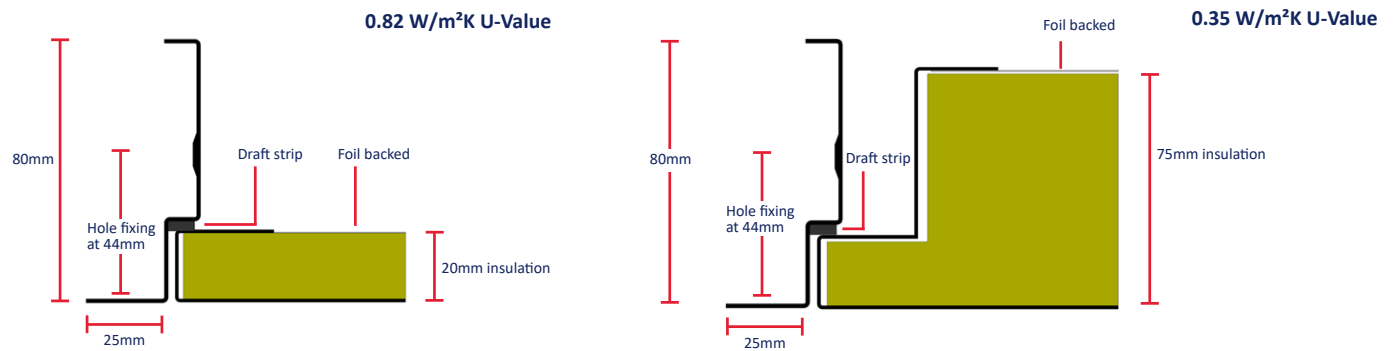
Z8003

Z8004



Scan to view the full product page on the Timloc website

Cross Sections



Product Codes

Metal 1 Hour Fire Rated Hinged Loft Access Doors

Description	Frame Fitting Size	Clear Opening Size	Overall Panel & Frame Size	Insulation U-value	Product Codes
Z-Series Fire Rated Metal Loft Door 542x630mm	542 x 630mm	520 x 580mm	590 x 680mm	0.82 W/m²K	Z8003
Z-Series Fire Rated Metal Loft Door 542x745mm	542 x 745mm	520 x 695mm	590 x 795mm	0.82 W/m²K	Z8004

Metal 1 Hour Fire Rated Hinged Loft Access Doors - Key Lock

Description	Frame Fitting Size	Clear Opening Size	Overall Panel & Frame Size	Insulation U-value	Product Codes
Z-Series Fire Rated Metal Loft Door 542x630mm - Key Lock	542 x 630mm	520 x 580mm	590 x 680mm	0.82 W/m²K	ZKL8003
Z-Series Fire Rated Metal Loft Door 542x745mm - Key Lock	542 x 745mm	520 x 695mm	590 x 795mm	0.82 W/m²K	ZKL8004

Metal 1 Hour Fire Rated Hinged Loft Access Doors - 0.35 U-Value

Description	Frame Fitting Size	Clear Opening Size	Overall Panel & Frame Size	Insulation U-value	Product Codes
Z-Series Fire Rated Metal Loft Door 542x630mm - 0.35 U-Value	542 x 630mm	520 x 580mm	590 x 680mm	0.35 W/m²K	Z9003
Z-Series Fire Rated Metal Loft Door 542x745mm - 0.35 U-Value	542 x 745mm	520 x 695mm	590 x 795mm	0.35 W/m²K	Z9004

Metal 1 Hour Fire Rated Hinged Loft Access Doors - 0.35 U-Value Key Lock

Description	Frame Fitting Size	Clear Opening Size	Overall Panel & Frame Size	Insulation U-value	Product Codes
Z-Series Fire Rated Metal Loft Door 542x630mm - 0.35 U-Value Key Lock	542 x 630mm	520 x 580mm	590 x 680mm	0.35 W/m²K	ZKL9003
Z-Series Fire Rated Metal Loft Door 542x745mm - 0.35 U-Value Key Lock	542 x 745mm	520 x 695mm	590 x 795mm	0.35 W/m²K	ZKL9004

LOFT-LOC

Loft Door Operating Poles

Metal loft door operating poles for the Timloc range of plastic and metal loft doors

Use

- To enable easy opening of Timloc range of plastic and metal loft doors

Features and Benefits

- Robust design
- Manufactured to BS EN ISO 9001-2015
- 600mm in length
- Individually bagged for convenience

Material and Colour Choice

- Manufactured from zinc plated mild steel tubing
- Z1162 - For use with Timloc Metal Hinged Loft Access Doors
- Z1170 - For use with Timloc Plastic Push-Up or Hinged Loft Access Doors (1168 & 1169)

Dimensions

- Z1162 - 600 x 12 x 75mm
- Z1170 - 600 x 12 x 75mm

How to Order

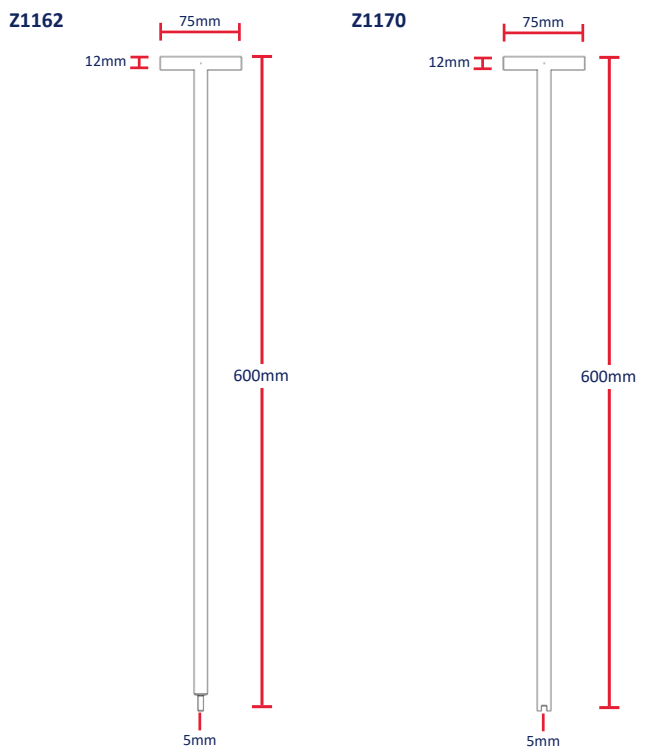
- Order as each
- State product code

Product Codes

Description	Product Codes
Square T-Key Loft Door Operating Metal Pole	Z1162
Slotted Loft Door Operating Metal Pole	Z1170



Product Dimensions



Scan to view the full product page on the Timloc website



Plastic Loft Doors | Technical information and installation advice

1168

Plastic Push-up Loft Access Door

- This loft access door is designed to fit between standard trussed rafters spaced accurately at 600mm centres and constructed in 38mm (1.5") thick timbers. If the roof trusses are not spaced at these centres or if thicker timbers are used then it will be necessary to form a suitable structural opening with a clear opening width of 562mm
- Trimmers should be positioned between the ceiling joists. These are required to fix the ends of the frame and support the plaster board. They should be spaced with a clear opening length of 665mm
- The roof timbers must be correctly spaced, straight and free from twist or distortion. If they are not the frame may be difficult to fit and the door may bind in the frame
- Fit the loft access door after the ceiling has been plasterboarded and skimmed but before the ceiling is decorated
- If the trimmed opening has been made slightly too large packers must be provided at the screw fixing points otherwise the action of tightening the screws will distort the frame
- Use ten fixing screws to secure the frame, three through each side and two through each end
- Never try to force the frame into an opening which is too small
- Do not overtighten the fixing screws as this could distort the frame
- Please note that push-up loft access doors of this type are not suitable for use with a telescopic loft ladder
- To ensure an airtight seal; apply decorators flexible caulking around the architrave frame where it meets the ceiling

1169

Plastic Hinged Drop Down Loft Access Door

- This loft access door is designed to fit between standard trussed rafters spaced accurately at 600mm centres and constructed in 38mm (1.5") thick timbers. If the roof trusses are not spaced at these centres or if thicker timbers are used then it will be necessary to form a suitable structural opening with a clear opening width of 562mm
- Trimmers should be positioned between the ceiling joists. These are required to fix the ends of the frame and support the plasterboard. They should be spaced with a clear opening length of 662mm
- The roof timbers must be correctly spaced, straight and free from twist or distortion. If they are not the frame may be difficult to fit and the door may bind in the frame
- Fit the loft access door after the ceiling has been plasterboarded and skimmed but before the ceiling is decorated
- If the trimmed opening has been made slightly too large packers must be provided at the screw fixing points otherwise the action of tightening the screws will distort the frame.
- Never try to force the frame into an opening which is too small
- Use ten fixing screws to secure the frame, three through each side and two through each end
- Do not overtighten the fixing screws as this could distort the frame
- To ensure an airtight seal; apply decorators flexible caulking around the architrave frame where it meets the ceiling
- If a telescopic loft ladder is to be used the ladder fixing mounts must be secured to the floor of the loft, ceiling joist or trimmer and not directly to the loft access door frame. It is important to ensure that there is adequate clearance within the loft space for the loft ladder to pivot and operate. It is recommended that a minimum of 1050mm clearance is provided horizontally and vertically at the end where the ladder is mounted

Metal Loft Doors | Technical Information and Installation Advice

Fire Rated Loft Access Doors

- The loft access doors are designed to fit between 38mm thick ceiling joists which are spaced at 600mm centres and lined with 9.5mm plasterboard giving a clear joist opening width of 542mm.
- If the ceiling joists are not spaced at these centres then it will be necessary to form a suitable structural opening with a clear opening width of 542mm
- Trimmers should be positioned between the ceiling joists. These are required to fix the ends of the frame and support the plasterboard. They should be spaced with a clear opening length of 745mm (1160) and 630mm (1161)
- The roof timbers must be correctly spaced, straight and free from twist or distortion. If they are not the frame may be difficult to fit and the door may bind in the frame
- If timber is used to trim the structural opening, then a layer of plasterboard or other proprietary material must be used to protect the timber.
- Fit the loft access door after the ceiling has been plasterboarded and skimmed but before the ceiling is decorated
- If the trimmed opening has been made slightly too large or if ceiling joists of less than 38mm thickness are being used additional packers must be provided to ensure a good fit into the ceiling aperture. These packers must be continuous along the side of the frame and not just localised at the screw fixing points
- Never try to force the frame into an opening which is too small
- Use ten fixing screws to secure the frame, three through each side and two through each end
- Do not overtighten the fixing screws as this could distort the frame
- To ensure an airtight seal; apply decorators flexible caulking around the architrave frame where it meets the ceiling
- If a telescopic loft ladder is to be used the ladder fixing mounts must be secured to the floor of the loft, ceiling joist or timber and not directly to the loft access door frame. It is important to ensure that there is adequate clearance within the loft space for the loft ladder to pivot and operate. It is recommended that a minimum of 1050mm clearance is provided horizontally and vertically at the end where the ladder is mounted

Air Leakage Testing and Performance Results

Timloc have completed a major test program with the BRE to demonstrate the air leakage capability of its core loft access door products. To ensure customer satisfaction we tested a sample range of competitors equivalent products to offer a like-for-like comparison.

Following the BRE testing program Timloc was the only company to pass with a product which demonstrated a zero - 0.00m³/(h.m²) air leakage at 50Pa. Its 1169 loft access door exceeded requirements set in the Building Regulation Part L1A & L2A, while fully complying with BS5250:2002 the Code of Practice for control of condensation in buildings.

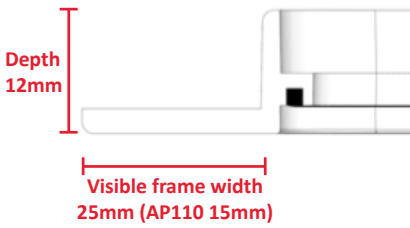
The objective of the testing was to measure the air leakage through a range of loft access doors.

There have been some recent changes to the Building Regulations designed to improve the energy efficiency of buildings. These changes have introduced new requirements to the air tightness of certain building types. For example, Part L1A & L2A states that a reasonable limit for the design air permeability of buildings is 8/(h.m²) at +50Pa. Hence loft access hatch specifiers might need to know the leakage rate of loft hatches at a pressure of +50Pa. (Timloc 1169 achieved 0.00m³/(h.m²) at +50Pa demonstrating full compliance.) There have also been some recent changes to BS5250:2011, the Code of Practice for control of condensation in buildings. Amendment 16119, issued on 23rd December 2005 introduced a clause giving recommendations for air tightness of ceilings. This new clause, 8.4.1.2, gives some rules for producing a well sealed ceiling which includes a requirement for loft hatches as follows:

The air leakage rate through an access loft hatch, including its frame, when tested to BS EN 1314101:2004 4.3 is less than 1m³/h at a pressure difference 2Pa. It can be assumed that "push-up" wooden hatch covers in a frame, constructed in-situ, with continuous compressible seals, will meet this criterion provided the weight of the door is at least 5.5kg. Hatch covers should either be heavy enough to compress the seal or be clamped, with a closed cell compressible seal, or "O-ring" between it and the frame. Drop-down hatch covers are more difficult to seal; it is recommended that proprietary units with a supplied hatch cover in a frame are used. Manufacturers can provide third party evidence that the leakage criterion is met'. (Timloc's 1168 drop in / push up plastic loft access door has two catches to ensure full seal compression).

Plastic Access Panels

The answer to unsightly controls and fittings



Can be used to provide access in ceilings

*excludes AP450 & AP450KL



Use

- Cost effective yet reliable and simple method for providing access to services and connections behind dry lined walls, ducts, ceilings (exc. AP450 and AP450KL) and cupboard units
- An ideal solution for meeting the gas safety industry and Building Regulation Part J's concealed boiler blue inspection access requirements (non-fire rated applications)

Features and Benefits

- Purpose made product saves time and money compared with traditional joiner-made or steel access doors
- Excellent aesthetic appearance and finish
- Textured finish allows painting if required
- Visible picture frame surround smartly conceals cut out edges and contributes to a faster installation
- Universal door handing
- Flush fitting door panel can be fully removed for maximum access
- Installed in minutes using basic hand tools and silicon/flexible sealant
- Catch clip closing mechanism across the range as standard
- Key lock options available
- Acoustic performance of 26dB

Quality

- Manufactured to BS EN ISO 9001 and BS EN ISO 14001
- Helps to meet Building Regulation document Part J (2010 edition)

Material and Colour Choice

- Tough and UV stabilised injection moulded HIPS plastic
- White finish

Installation Advice

- Cut hole to size, making sure that it is straight and level
- Apply silicon or other suitable grade building adhesive to the back of the frame
- Check which way that you want the door to hinge
- Press the frame firmly into place, checking it is straight and level
- Do not operate until the adhesive has set completely
- To open the door, use a screw driver in the slot and lever up (Fig. 1)
- To remove the door, open the door slightly (Fig. 2.) and pull away from the hinge position maintaining the door at a slight angle (Fig. 3). This does not apply to panels AP110 and AP200 which are clip fit door panels
- To replace the door, reverse the removal process

Care and Maintenance

- Clean using a soft cloth with a mild detergent

How to Order

- State which size of panel is required and confirm the frame fitting size
- State if the key lock option is required

Bill of Quantity

L20 Doors/Shutters/Hatches

Clause

630^ HATCHES

- Manufacturer: Timloc Building Products, Timloc House, Ozone Park, Howden, East Yorkshire, DN14 7SD. T: 01405 765567 W: www.timloc.co.uk
- Type: Plastic access panels
- Product code: AP300 (see other product codes/variations of sizes)
- Frame fitting size: 305 x 305mm
- Application: Wall, ceiling or voids
- Frame type: Picture
- Colour: Textured white HIPS plastic

Product Codes

Frame Fitting Size	Clear Opening Size	Overall Panel & Frame Size	Door Type	Key Lock	Product Codes
115 x 165mm	100 x 150mm	135 x 185mm	Clip fit	N/A	AP110
155 x 235mm	140 x 220mm	195 x 275mm	Hinged	N/A	AP150
205 x 205mm	190 x 190mm	245 x 245mm	Clip fit	N/A	AP200
305 x 305mm	290 x 290mm	345 x 345mm	Hinged	N/A	AP300
470 x 470mm	455 x 455mm	510 x 510mm	Hinged	N/A	AP450*
155 x 235mm	140 x 220mm	195 x 275mm	Hinged	Yes	AP150KL
305 x 305mm	290 x 290mm	345 x 345mm	Hinged	Yes	AP300KL
470 x 470mm	455 x 455mm	510 x 510mm	Hinged	Yes	AP450KL*

*Not suitable for ceiling installations

AP150

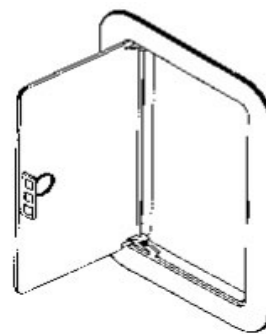


Fig.1

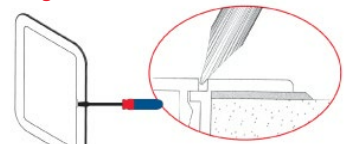


Fig.2



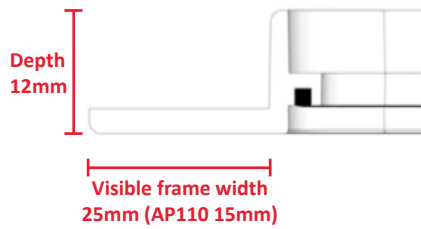
Fig.3



Scan to view the full product page on the Timloc website

Airtight Plastic Access Panels

Fully airtight and high level acoustic performance plastic access panels



Can be used to provide access in ceilings

*excludes AP450 & AP450KL



Use

- Provides access to services and connections behind dry lined walls, ducts, ceilings and cupboard units
- Complete solution to meet the highest levels of Building Regulation Part L and Building Regulation Part J and the gas safety industry's concealed boiler flue inspection requirements (non-fire rated applications)

Features and Benefits

- Purpose made product saves time and money compared with traditional joiner-made or steel access doors
- Unique airtight seal design reduces the air permeability to 0.00/h.m at +50pa
- Flush fitting door panels that can be fully removed for maximum access
- Excellent aesthetic appearance and finish
- Textured finish allows painting if required
- Visible picture frame surround smartly conceals cut out edges and contributes to a faster installation
- Universal door handing
- Installed in minutes using basic hand tools and silicon/flexible sealant
- Clip fit door panels with catch clip closing mechanism
- Acoustic performance of 31dB

Quality

- Manufactured to BS EN ISO 9001 and BS EN ISO 14001
- Helping to meet Building Regulation:
 - Document Part J – Concealed Flues in Voids (2010 edition)
 - Document Part E – Resistant to Sound (2003 edition)
 - Part L1 and L2 – Conservation of Fuel and Power (2013 edition)

Material and Colour Choice

- Tough and UV stabilised injection moulded HIPS plastic
- White finish

Installation Advice

- Cut hole to size (see frame fitting size), making sure that it is straight and level
- Apply silicon or other suitable grade building adhesive to the back of the frame
- Press the frame firmly into place, checking it is straight and level
- Do not operate until the adhesive has set completely
- Simply push the clip fit door panel into the frame

How to Order

- State which size of panel is required and confirm the hole cutting size

Care and Maintenance

- Clean using a soft cloth with a mild detergent

Bill of Quantity

L20 Doors/Shutters/Hatches

Clause

630^ HATCHES

- Manufacturer: Timloc Building Products, Timloc House, Ozone Park, Howden, East Yorkshire, DN14 7SD. T: 01405 765567 W: www.timloc.co.uk
- Type: Airtight access panels
- Product code: AP300AT (see other product codes/variations of sizes)
- Frame fitting size: 305 x 305mm
- Application: Wall, ceiling, cupboard or voids
- Frame type: Picture
- Colour: Textured white HIPS plastic

Product Codes

Frame Fitting Size	Clear Opening Size	Overall Panel & Frame Size	Door Type	Product Codes
115 x 165mm	100 x 150mm	135 x 185mm	Clip fit	AP110AT
155 x 235mm	140 x 220mm	195 x 275mm	Clip fit	AP150AT
205 x 205mm	190 x 190mm	245 x 245mm	Clip fit	AP200AT
305 x 305mm	290 x 290mm	345 x 345mm	Clip fit	AP300AT
470 x 470mm	455 x 455mm	510 x 510mm	Clip fit	AP450AT

Scan to view the full product page on the Timloc website



Z-SERIES

Metal Access Panels

Metal access panels for access to mechanical, electrical and other building services

Use

- Provides access to services and connections behind dry lined walls, ducts and ceilings
- For applications where plastic access panels are not suitable and a fire rating is not required
- Ideal solution for meeting Part J and the gas safety industry's concealed boiler flue inspection access requirements (non-fire rated applications)

Features and Benefits

- Purpose made product saves time and money compared with traditional joiner-made access doors
- Excellent aesthetic appearance and finish
- Flush fitting door panels
- Visible picture frame surround smartly conceals cut out edges and contributes to a faster installation
- Smooth and enduring polyester powder coated finish
- Allows for painting if required
- Quick and straight forward to install
- 50mm deep frame for deeper wall and ceiling fixing
- Hinged door panel with budget lock

Quality

- Helps to meet Building Regulation Document Part J – Concealed Flues in Voids (2010 edition)

Material and Colour Choice

- Electro galvanised mild steel
- Polyester powder coated smooth finish 20% gloss
- White – RAL 9010

Installation Advice

- Please contact the Timloc Technical team

Care and Maintenance

- Clean using a soft cloth with a mild detergent

How to Order

- State which size of panel is required and confirm the frame fitting size

Scan to view the full product page on the Timloc website



Z-Series metal access panel | Z2001

Z-Series metal access panel | Z2002

Bill of Quantity

L20 Doors/Shutters/Hatches

Clause

630^ HATCHES

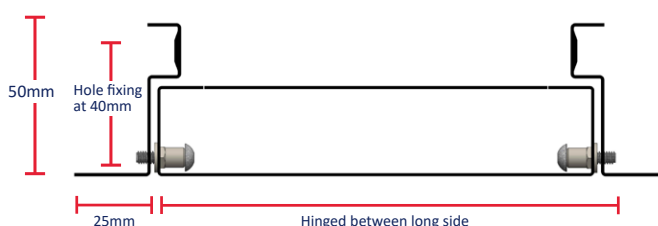
- Manufacturer: Timloc Building Products, Timloc House, Ozone Park, Howden, East Yorkshire, DN14 7SD. T: 01405 765567 W: www.timloc.co.uk
- Type: Timloc Metal Access Panels - Picture Frame
- Application: Wall, ceiling, cupboard or voids
- Frame type: Picture
- Colour: White - RAL 9010 smooth 20% gloss polyester powder coating

Product Codes

Frame Fitting Size	Clear Opening Size	Overall Panel & Frame Size	Product Codes
155 x 155mm	128 x 110mm	198 x 198mm	Z2001
155 x 235mm	110 x 208mm	198 x 278mm	Z2002
205 x 205mm	178 x 160mm	248 x 248mm	Z2003
305 x 305mm	278 x 260mm	348 x 348mm	Z2004
355 x 355mm	328 x 310mm	398 x 398mm	Z2005
455 x 455mm	428 x 410mm	498 x 498mm	Z2006
555 x 555mm	528 x 518mm	598 x 598mm	Z2007
605 x 305mm	578 x 260mm	648 x 348mm	Z2008
605 x 605mm	578 x 560mm	648 x 648mm	Z2009

Cross section

Z-Series metal access panels



Metal 1 Hour Fire-Rated Access Panels

Multi performance 1 hour fire rated steel access panels with mineral wool and draught seals

Use

- Provides access to services and connections behind dry lined walls, ducts, ceilings where a 1 hour fire rating is required
- Projects with additional reduced air leakage and /or acoustic performance requirements
- Ideal solution for meeting Part J and the gas safety industry's concealed boiler flue inspection access requirements (1 hour fire rated applications)

Features and Benefits

- Purpose made product saves time and money compared with traditional joiner-made access doors
- independently tested fire rating
- Mineral wool insulation and draught stripped to reduce the opportunity of air leakage in application
- 32mm low profile frame ideal for installation with 15mm plaster board
- Flush fitting door panels with excellent aesthetic appearance and finish
- Visible picture frame surround smartly conceals cut out edges and contributes to a faster installation
- Enduring polyester powder coated finish
- Allows for painting if required
- Quick and straightforward to install
- Universal door handing
- Hinged door panel with T-key lock mechanism and key lock
- Quick release panel mechanism fully removes the door for maximum access
- Acoustic performance of 33dB (contact Technical for more information)

Quality

- Manufactured to BS EN ISO 9001 and BS EN ISO 14001
- Helping to meet Building Regulation: - Document Part J – Concealed Flues in Voids (2010 edition)
- - Document Part E – Resistant to Sound (2003 edition)
- - Part L1 and L2 – Conservation of Fuel and Power (2013 edition)

Material and Colour Choice

- Electro galvanised mild steel
- Glass wool insulation (45kg/m3)
- Polyester powder coated smooth finish 20% Gloss
- White – RAL 9016

Installation Advice

- Please contact the Timloc Technical team for installation advice

Care and Maintenance

- Clean using a soft cloth with a mild detergent
- Spare keys available upon request

How to Order

- State which size of panel is required and confirm the frame fitting size



Bill of Quantity

L20 Doors/Shutters/Hatches
Clause

630^ HATCHES

- Manufacturer: Timloc Building Products, Timloc House, Ozone Park, Howden, East Yorkshire, DN14 7SD. T: 01405 765567 W: www.timloc.co.uk
- Type: Timloc Metal 1 Hour Fire Rated Access Panels
- Product code: Example APC300x300CR (see other product codes/variation of sizes)
- Frame fitting size: Example 305x305mm (see other product codes/variation of sizes)
- Application: Wall, ceiling or voids
- Frame type: Picture
- Colour: White - RAL 9016 Smooth Polyester Powder Coating

Product Codes

Frame Fitting Size	Clear Opening Size	Overall Panel & Frame Size	Door Type	Product Codes
155 x 155mm	110 x 110mm	200 x 200mm	Hinged with T-key lock	APC150x150CR
155 x 235mm	110 x 190mm	200 x 280mm	Hinged with T-key lock	APC150x230CR
205 x 205mm	160 x 160mm	250 x 250mm	Hinged with T-key lock	APC200x200CR
305 x 305mm	260 x 260mm	350 x 350mm	Hinged with T-key lock	APC300x300CR
455 x 455mm	410 x 410mm	500 x 500mm	Hinged with T-key lock	APC450x450CR
555 x 555mm	510 x 510mm	600 x 600mm	Hinged with T-key lock	APC550x550CR
605 x 605mm	560 x 560mm	650 x 650mm	Hinged with T-key lock	APC600x600CR
155 x 155mm	110 x 110mm	200 x 200mm	Hinged with key lock	APC150x150CRKL
155 x 235mm	110 x 190mm	200 x 280mm	Hinged with key lock	APC150x230CRKL
205 x 205mm	160 x 160mm	250 x 250mm	Hinged with key lock	APC200x200CRKL
305 x 305mm	260 x 260mm	350 x 350mm	Hinged with key lock	APC300x300CRKL
455 x 455mm	410 x 410mm	500 x 500mm	Hinged with key lock	APC450x450CRKL
555 x 555mm	510 x 510mm	600 x 600mm	Hinged with key lock	APC550x550CRKL
605 x 605mm	560 x 560mm	650 x 650mm	Hinged with key lock	APC600x600CRKL

Scan to view the full product page on the Timloc website





Adapt-Air

Product	Page No.
Adapt-Air	75
Adapt-Air Test Data	77

**PRODUCT
VIDEO**

AVAILABLE

**SCAN
TO VIEW**





Simple to install pre-assembled sets, which quickly and conveniently adapts extraction ductwork to terminate at a standard plastic airbrick.

Use

At floor level voids and external walls
 Suitable for round and rectangular rigid extraction ductwork from:

- Bathrooms
- WC cloakrooms
- Utility rooms
- Kitchens

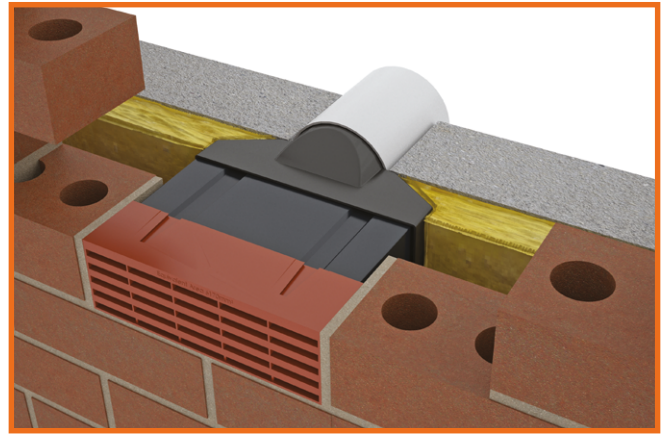
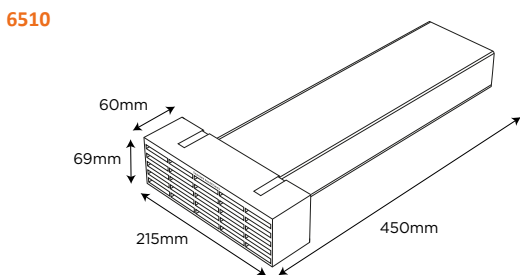
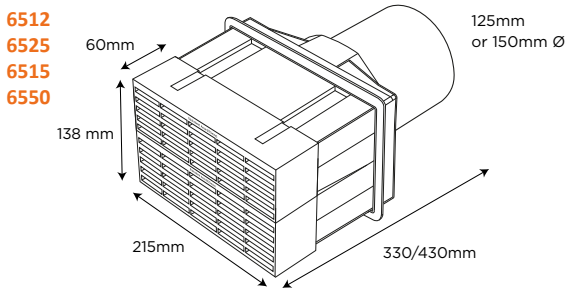
Features and Benefits

- Enables rigid extraction ductwork termination to be built in as part of the brickwork package
- Doesn't restrict or interrupt ducting airflow
- Convenient '1 product code' assembled kits for immediate installation
- Eliminates the requirement for retrospective through wall core drilling
- Enables 1st fix ceiling & wall duct extraction and wall connections to outlet vent
- Durable and totally resistant to decay
- Airbricks available in Terracotta, Buff, Black, Brown, Grey, White, and Blue Black
- Suitable for working temperatures of -20 to 60°C
- Allows for NHBC best practice recommendations

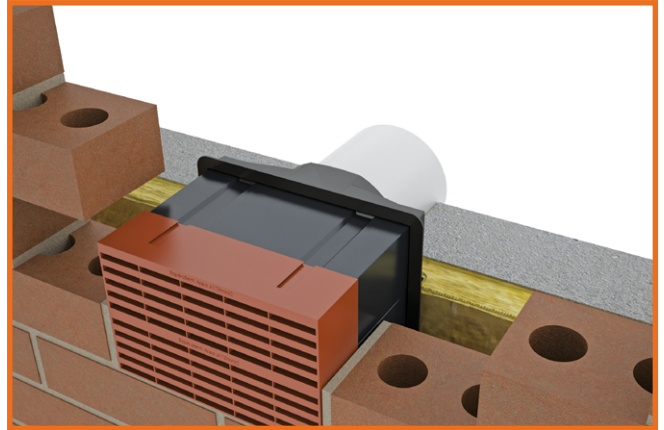
Quality

- Helping to meet Building Regulation Part F
- Equivalent area marking to front face of airbrick to comply with BS EN 13141-1
- Manufactured to BS EN ISO 9001

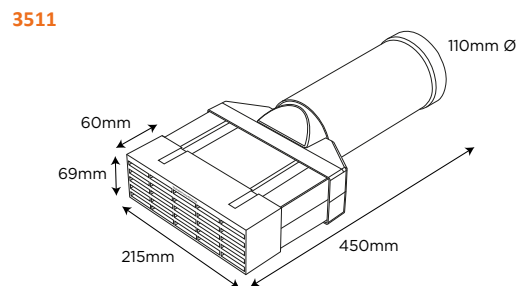
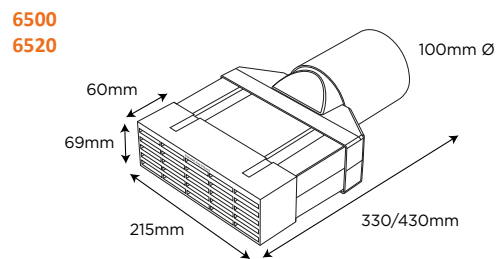
Product Dimensions



6500 Adapt-Air Single Airbrick

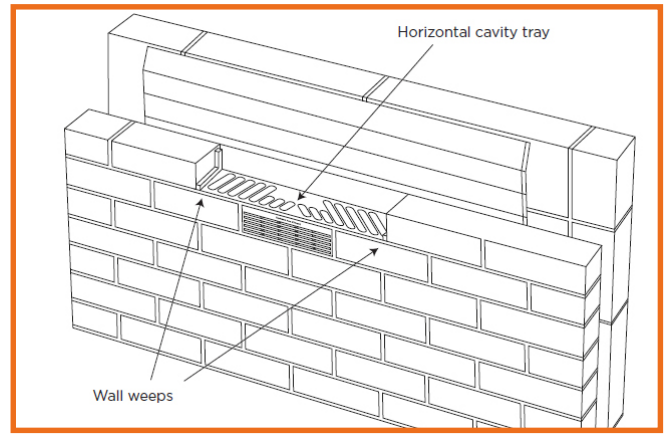


6512 Adapt-Air Double Airbrick





Simple to install pre-assembled sets, which quickly and conveniently adapts extraction ductwork to terminate at a standard plastic airbrick.



Material and Colour Choice

- Airbrick manufactured from UV stabilised polypropylene
- Available in Terracotta, Buff, Black, Brown, Grey, White, and Blue Black
- All other components manufactured from PVC/PP

Installation Advice

- Build in the set's airbrick (to replace a regular brick) as normal as brick and blockwork proceeds
- The installed position and level of the set is determined by the extraction fan connections
- The kit must be installed with a slight angle to the external leaf to allow for moisture drainage
- The set can be flush or project beyond the inner wall leaf to allow for the fitting of additional ducting or an extraction fan
- The cavity wall construction will determine most suitable option length kit required
- As with all through cavity wall components install a DPC cavity tray, with wall weep and stop ends, above the installed adapter set to collect any water ingress. We recommend the Inter-loc 4 horizontal cavity tray and 1143 or Invisiweep

How to Order

- Quantity will be relative to the number of ventilation terminals required by the project
- Ensure that the correct shaped set has been selected to suit the ductwork
- State the airbrick colour required



Scan to view the full product page on the Timloc website

Product Codes

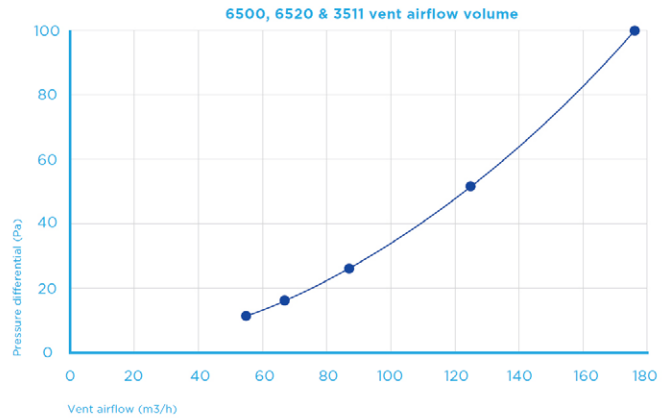
Description	Duct Size	Overall Length	Product Codes
Adapt-Air Single Airbrick 330mm x 100mm	100mm Ø	330mm	6500 + airbrick colour
Adapt-Air Single Airbrick 430mm x 100mm	100mm Ø	430mm	6520 + airbrick colour
Adapt-Air Single Airbrick 450mm x 110mm	110mm Ø	450mm	3511 + airbrick colour
Adapt-Air Rectangular Single Airbrick 450mm x 100 x 54mm	100 x 54mm	450mm	6510 + airbrick colour
Adapt-Air Double Airbrick 330mm x 125mm	125mm Ø	330mm	6512 + airbrick colour
Adapt-Air Double Airbrick 430mm x 125mm	125mm Ø	430mm	6525 + airbrick colour
Adapt-Air Double Airbrick 330mm x 150mm	150mm Ø	330mm	6515 + airbrick colour
Adapt-Air Double Airbrick 430mm x 150mm	150mm Ø	430mm	6550 + airbrick colour

State required colour at the end of the product code: Terracotta: **TE**, Buff: **BU**, Grey: **GR**, Brown: **BR**, Black: **BL**, White: **WH**

6500 | 6520 | 3511

Adapt-Air single airbrick
100mm diam tube (110mm adapter)

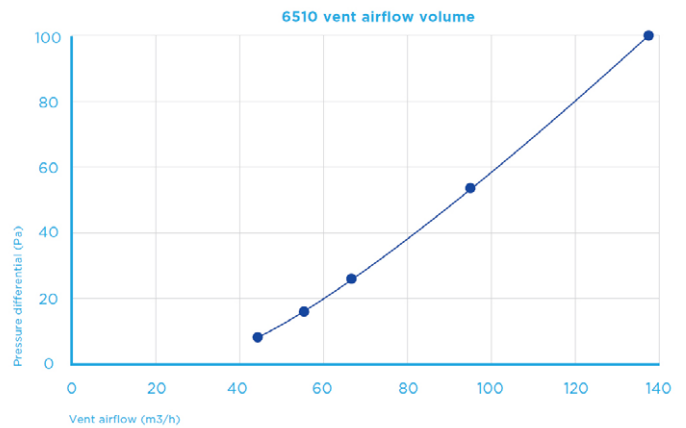
6500, 6520 & 3511 airflow		
m3/h	Pa	L/s
55	10	15.28
68	15	18.89
88	25	24.44
124	50	34.44
177	100	49.17



6510

Adapt-Air single airbrick 100mm
diam tube 100mm x 54mm duct

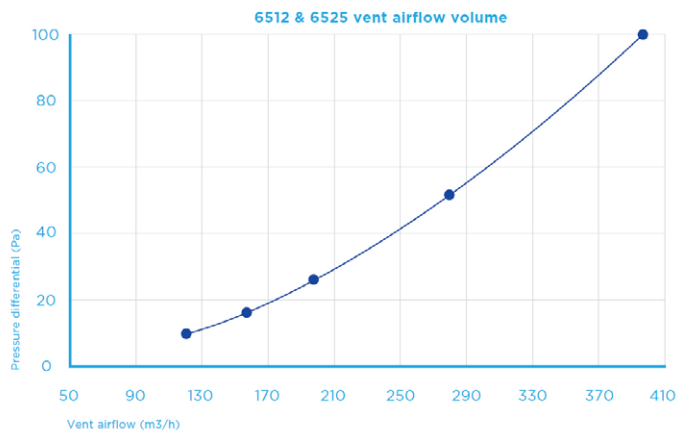
6510 airflow		
m3/h	Pa	L/s
43	10	11.94
54	15	15.00
68	25	18.89
94	50	26.11
137	100	38.09



6512 | 6525

Adapt-Air double airbrick
125mm diam tube

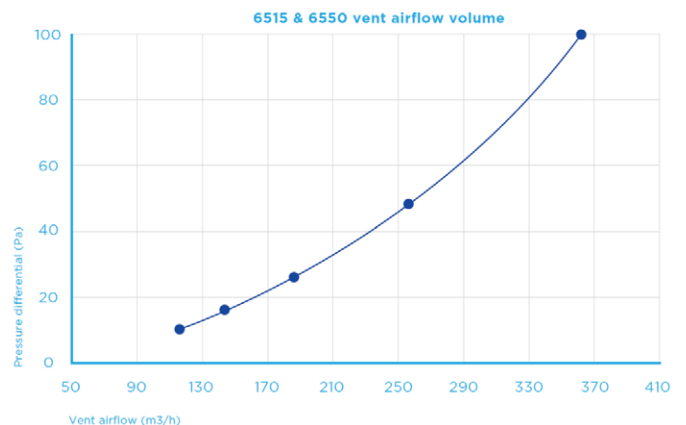
6512 & 6525 airflow		
m3/h	Pa	L/s
123	10	34.00
155	15	43.06
195	25	54.17
279	50	77.50
396	100	110.0



6515 | 6550

Adapt-Air double airbrick
150mm diam tube

6515 & 6550 airflow		
m3/h	Pa	L/s
114	10	31.67
140	15	38.89
181	25	50.28
256	50	71.11
363	100	100.83



RAD-SEAL

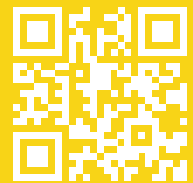
by **timloc**

Product	Page No.
Rad-seal 15mm Face-Fix Radiator Pipe Guide & Seal	79
Rad-seal 10mm Face-Fix Radiator Pipe Guide & Seal	80
Rad-seal Recessed Radiator Pipe Guide & Seal	81

**PRODUCT
VIDEO**

AVAILABLE

**SCAN
TO VIEW**



RAD-SEAL 15

by **timloc**

Face-fix radiator pipe guide and seal to eliminate potential air leakage and heat loss at vulnerable through-wall radiator pipework entry points. For 15mm pipework.

Use

- At the point of entry of through-wall **15mm** plastic radiator pipework
- Within all wall constructions that present a concealed pipe void including:
- Studded dry lined walls
- Plaster dab slab walls

Features and Benefits

- Contributes to Part L's required air leakage performance
- Protects the pipework and plaster from direct chafing
- Straight-forward and quick face fix installation
- Projects by just 23.5mm from the wall
- Securely positions the pipework into the required direction for connection
- Eliminates pipework kinking
- Patent-pending design

Quality

- Manufactured to BS EN ISO 9001 and BS EN ISO 14001
- Helps to meet:
 - Building Regulation Document Part L - Conservation of Fuel and Power

Material and Colour Choice

- Main unit body - white recycled Polypropylene
- Gasket seal entry and seals - Thermoplastic Elastomer

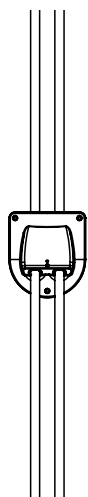
Installation Advice

- Please refer to timloc.co.uk for full recommended installation guidance

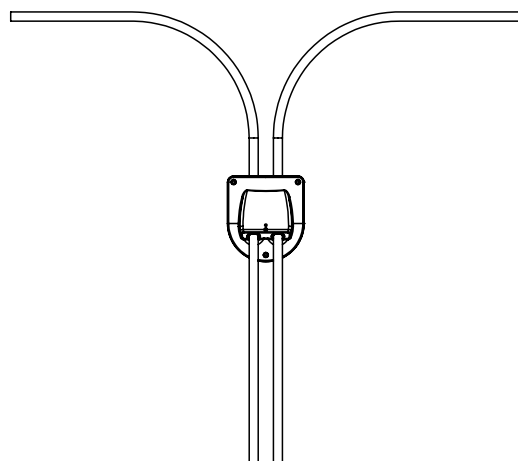
Technical Considerations

- Accepts routed pipework from:

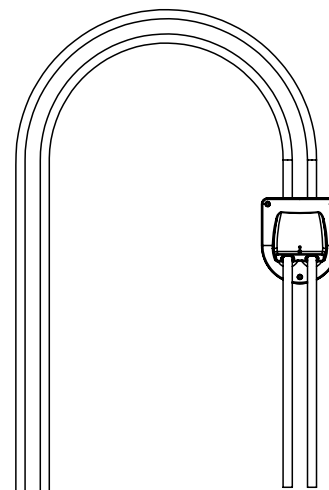
A. Ground floor routing



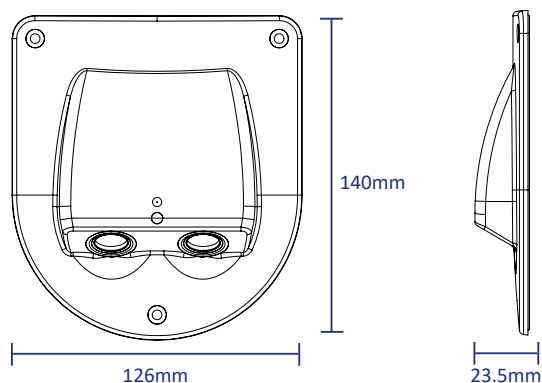
B. Horizontal routing



C. Upper floor routing



Product Dimensions



Product Code

Description	Height	Width	Box Qty	Product Code
Rad-Seal Face-Fix 15mm	140mm	126mm	20	2222



Scan to view the full product page on the Timloc website

RAD-SEAL 10

by **timloc**

Face-fix radiator pipe guide and seal to eliminate potential air leakage and heat loss at vulnerable through-wall radiator pipework entry points. For **10mm** pipework.

Use

- At the point of entry of through-wall **10mm** plastic radiator pipework
- Within all wall constructions that present a concealed pipe void including:
- Studded dry lined walls
- Plaster dab slab walls

Features and Benefits

- Contributes to Part L's required air leakage performance
- Protects the pipework and plaster from direct chafing
- Straight-forward and quick face fix installation
- Projects by just 23.5mm from the wall
- Securely positions the pipework into the required direction for connection
- Eliminates pipework kinking
- Patent-pending design

Quality

- Manufactured to BS EN ISO 9001 and BS EN ISO 14001
- Helps to meet:
 - Building Regulation Document Part L - Conservation of Fuel and Power

Material and Colour Choice

- Main unit body - white recycled Polypropylene
- Gasket seal entry and seals - Thermoplastic Elastomer

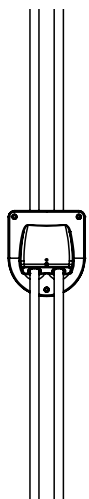
Installation Advice

- Please refer to timloc.co.uk for full recommended installation guidance

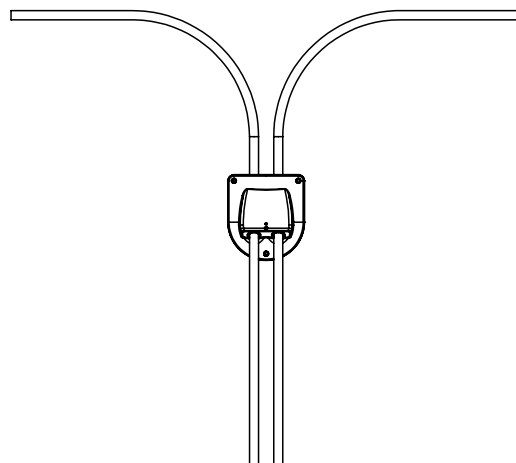
Technical Considerations

- Accepts routed pipework from:

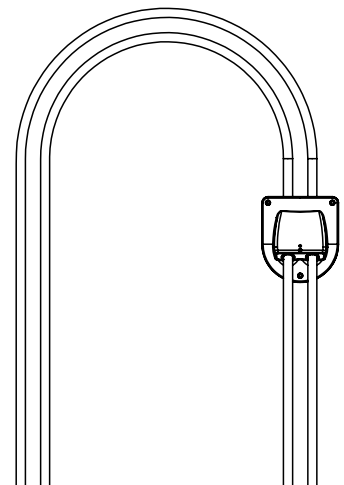
A. Ground floor routing



B. Horizontal routing

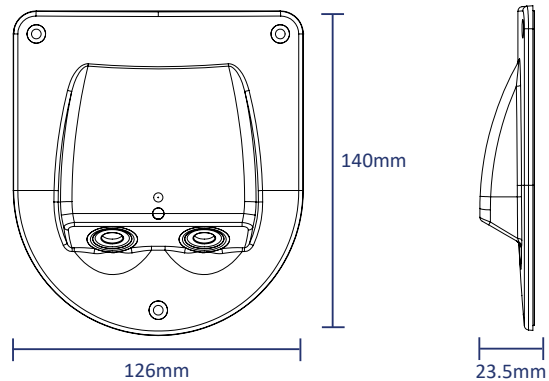


C. Upper floor routing



ALSO
AVAILABLE
FOR **15MM**
PIPEWORK

Product Dimensions



Product Code

Description	Height	Width	Box Qty	Product Code
Rad-Seal Face-Fix 10mm	140mm	126mm	20	2221



Scan to view the full product page on the Timloc website

RAD-SEAL

by **timloc**

Recessed radiator pipe guide and seal to eliminate potential air leakage and heat loss at vulnerable through-wall radiator pipework entry points. For 10mm pipework.

Use

- At the point of entry of through wall 10mm plastic radiator pipework
- Within all wall constructions that present a concealed pipe void including studded dry lined walls and plaster dab solid walls

Features and Benefits

- Contributes to Part L's required air leakage performance
- Air permeability measured and verified by BRE at Part L's 50Pa as:
 - 0.24m³ (h.m²) under positive pressure test conditions
 - 0.30m³ (h.m²) under negative pressure test conditions
- Centrally and neatly contains the pipework during the plastering process
- Protects the pipework and plaster from direct chafing
- Replaces requirement of electrical back boxes, intumescent foams or sealants
- Straight forward and quick face fix installation
- Projects by just 5mm from the wall
- Securely positions the pipework into the required direction for connection
- Eliminates pipework kinking

Quality

- Manufactured to BS EN ISO 9001 and BS EN ISO 14001
- Helping to meet Building Regulation:
 - Document Part L – Conservation of Fuel and Power

Material and Colour Choice

- Main unit body – white Polypropylene
- Gasket seal entry and seals – light grey Thermoplastic Elastomer

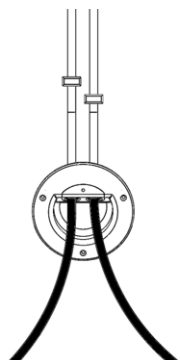
Installation Advice

- Please refer to timloc.co.uk for full recommended installation guidance

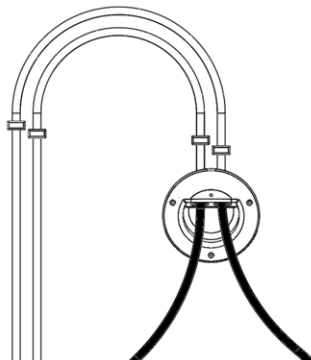
Technical Considerations

Accepts routed pipework from:

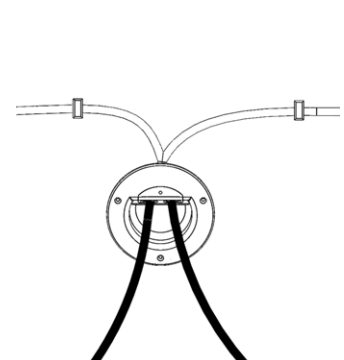
A. Ground floor routing



B. Horizontal routing



C. Upper floor routing



Product Code

Description	Diameter	Box Quantity	Product Code
Rad-Seal Recessed	140mm	10	1115



Scan to view the full product page on the Timloc website

EVERYTHING

UNDER ONE ROOF

The Roofline by Timloc range encompasses the ancillary products required within a roofing application. Our products range from ventilation systems for roofs, eaves and soffits to one-kit solutions for dry ridge and hip installations.



ROOFLINE

by **timloc**

Product	Page No.
Push-in Soffit Vent	84
Soffit Vent Type C	85
Corbel Vent	86
Over Fascia Vent	87
1m Over Fascia Vent	88
Over Fascia Ventilation System	89
Rafter Roll	90
6m Eaves Vent Pack	91
Felt Support Tray	92
Eaves Comb Filler	93
Lap Vent	94
3m 6m 10m Roll Out Dry Fix Ridge Kits	96
6m Integrated Dry Ridge Kit	97
6m Clay Ridge Kit	98
6m Roll Out Dry Fix Hip Kit	99
Hip Accessory Kit	100
Ambi-Verge Universal Dry Fix Verge System	102
Dry Fix Verge System for Profiled Roof Tiles	104
Interlocking Plain Edge Dry Verge	106

Product	Page No.
Thin Leading Edge Dry Verge	108
Continuous Dry Verge	110
Ambi-Soaker - Plain	112
Ambi-Soaker - Interlocking Plain	113
Ambi-Soaker - Slate	114
Ambi-Soaker - Thin Leading Edge	115
Ambi-Soaker - Flat	116
InVentive Roof Vents Product Range Table	120
InVentive Roof Vents Range	121
110mm Flexi-Pipe Kits	140
Multi Stepped Duct Adapter	141
Hooded Slate Vent Adapter	142
Standard Roof Tile Vent Adapter	143
Plain Roof Tile Vent Adapter	144
Inline Slate Vent Adapter	145
MemBreathe 115gsm Breathable Membrane	146
MemBreathe 135gsm Breathable Membrane	147
MemBreathe 165gsm Breathable Membrane	148
PbFree Lead-free Flashing	149

**CATEGORY
GUIDE**

AVAILABLE

SCAN
TO VIEW



Push-In Soffit Vent

Efficient, circular ventilator in a range of colours

Use

- For roof eaves ventilation
- For remedial work on existing roofs
- On roofs requiring ventilation equivalent to a 10mm continuous opening
- On roofs where the eaves incorporate a soffit board

Features and Benefits

- Efficient, unobtrusive and easy to fit
- Can be fitted to existing soffit boards in situ
- 4mm wide holes comply with BS 5250 : 2021
- Durable and totally resistant to decay
- UV stabilised and colourfast

Quality

- Satisfies all NHBC requirements
- Manufactured to BS EN ISO 9001 and BS EN ISO 14001
- Complies with all relevant Building Regulations
- Meets all relevant British Standards

Material and Colour Choice

- Manufactured by injection moulding in polypropylene
- Available in grey, white, black or brown

Products in the System

Push in vents - 1139/1140/1141/1142

- All provide a free airflow of 2000mm² per unit and should be spaced at 200mm centres to achieve ventilation equivalent to a continuous 10mm opening

Installation Advice

- Use to ventilate pitched roofs, where the pitch of the roof is 15 degrees or more, and the roof void is attic or loft space
- Do not use to ventilate pitched roofs where the pitch of the roof is less than 15 degrees, flat roofs or any roof where living accommodation is contained within the roof space
- Space ventilators at 200mm centres
- Take care to ensure the fixing holes are cut accurately with a diameter of between 69-70mm. If the holes are oversize, the ventilators will not fix securely
- The ventilators should be a firm push fit into the fixing holes
- Ventilation must be provided for the full length of the eaves and along both sides of the building to create a cross flow ventilation action

Please see technical section for more details.

How to Order

- Specify which colour is preferred
- Measure the overall length of the eaves to be ventilated and divide by 200mm to determine the number of ventilators required



1139



1140



1141



1142



Bill of Quantity

G20 Carpentry/Timber Framing/First Fixing Clause

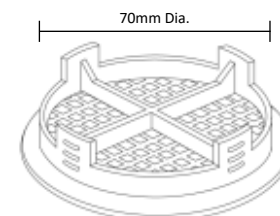
910^A | EAVES SOFFIT VENTILATION

- Manufacturer: Timloc Building Products, Timloc House, Ozone Park, Howden, East Yorkshire, DN14 7SD. T: 01405 765567 W: www.timloc.co.uk
- Product Reference: 1139/1140/1141/1142
- Type: Push in Soffit Vent (70mm diameter)
- Colour: (Black, White, Brown, Grey)
- Airway: Provide the equivalent of a continuous opening of not less than 10mm for the full length of eaves.

Product Codes

Description	Colour	Pack Quantity	Product Code
Push-In Soffit Vent	Grey	10	1139
Push-In Soffit Vent	White	10	1140
Push-In Soffit Vent	Black	10	1141
Push-In Soffit Vent	Brown	10	1142

Product Dimensions



Scan to view the full product page on the Timloc website

Soffit Vent Type C

Efficient, strip type eaves ventilator

Use

- For roof eaves ventilation
- On roofs where the eaves incorporate a soffit board
- With soffit boards of between 6mm and 9mm in thickness

Features and Benefits

- Efficient, unobtrusive and easy to fit
- 4mm wide slots comply with BS 5250 : 2021
- Durable and totally resistant to decay
- UV stabilised and colourfast

Quality

- Satisfies all NHBC requirements
- Manufactured to BS EN ISO 9001 and BS EN ISO 14001
- Complies with all relevant Building Regulations
- Meets all relevant British Standards

Material and Colour Choice

- Manufactured by extrusion in UPVC
- Available in white or brown - 1137 also available in black

Products in the System

1137

- Provides ventilation equivalent to a continuous 10mm opening (10,000mm² per metre run).

1138

- Provides ventilation equivalent to a continuous 25mm opening (25,000mm² per metre run).
- Both products are supplied in 2.4m lengths.

Installation Advice

- Use product 1137 to ventilate pitched roofs, where the pitch of the roof is 15 degrees or more, and the roof void is attic or loft space
- Use product 1138 to ventilate pitched roofs, where the pitch of the roof is less than 15 degrees, flat roofs or any roof where living accommodation is contained within the roof space
- Ideally the soffit board should be 6mm in thickness. Thicker boards up to 9mm can be accommodated with care, but it may be necessary to chamfer the edge of the board to make installation easier
- Ensure the ventilator is fixed securely to the back of the fascia board using all the fixing holes provided. Screws are preferable, but nails may be used with care
- Ventilation must be provided for the full length of the eaves and along both sides of the building to create a cross flow ventilation action

Please see technical section for more details.

How to Order

- Determine whether the roof design requires ventilation equivalent to a continuous 10mm opening (1137), or 25mm opening (1138)
- Specify which colour is preferred
- Measure the overall length of the eaves to be ventilated and divide by 2.4m to determine the number of lengths required



Bill of Quantity

Soffit ventilator strip 2.4m type C (10mm airflow)

G20 Carpentry/Timber Framing/First Fixing Clause

910^ EAVES SOFFIT VENTILATION

- Manufacturer: Timloc Building Products, Timloc House, Ozone Park, Howden, East Yorkshire, DN14 7SD. T: 01405 765567 W: www.timloc.co.uk
- Soffit boards: Fix to leave a continuous ventilation opening not less than 10mm wide for full length of eaves
- Fit a propriety Soffit Ventilator Strip Type C across the required opening to prevent large insect entry.
- Product Reference: 1137
- Type: Soffit Ventilator Strip 2.4m Type C (10mm Airflow)
- Colour: (Black, White, Brown)

Soffit ventilator strip 2.4m type C (25mm airflow)

G20 Carpentry/Timber Framing/First Fixing Clause

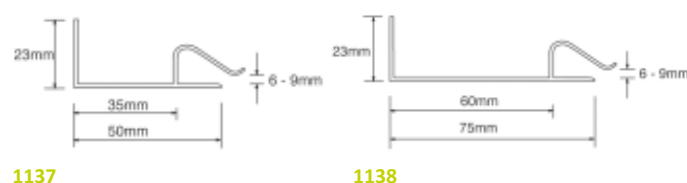
910^ EAVES SOFFIT VENTILATION

- Manufacturer: Timloc Building Products, Timloc House, Ozone Park, Howden, East Yorkshire, DN14 7SD. T: 01405 765567 W: www.timloc.co.uk
- Soffit boards: Fix to leave a continuous ventilation opening not less than 25mm wide for full length of eaves
- Fit a propriety Soffit Ventilator Strip Type C across the required opening to prevent large insect entry.
- Product Reference: 1138
- Type: Soffit Ventilator Strip 2.4m Type C (25mm Airflow)
- Colour: (White, Brown)

Product Codes

Description	Free Airflow	Colour	Pack Qty	Product Code
Soffit Vent Type C	10,000mm ² per meter	White	10	1137WH
Soffit Vent Type C	10,000mm ² per meter	Brown	10	1137BR
Soffit Vent Type C	10,000mm ² per meter	Black	10	1137BL
Soffit Vent Type C	25,000mm ² per meter	White	10	1138WH
Soffit Vent Type C	25,000mm ² per meter	Brown	10	1138BR

Product Dimensions



1137

1138



Scan to view the full product page on the Timloc website

Corbel Vent

Designed for use with corbelled brickwork details

Use

- For roof eaves ventilation
- On roofs where ventilation equivalent to a continuous 10mm opening is required
- On roofs where the eaves are finished with corbelled masonry
- On roofs which do not incorporate a soffit board or fascia board

Features and Benefits

- Efficient, very unobtrusive and easy to fit
- Superior strength construction - will carry the weight of the bottom row of tiles
- Can be installed without having to drill the brickwork by using the special fixing clips provided and building them into the perp mortar joints
- 4mm wide ventilation slots comply with BS 5250 : 2021
- Durable and totally resistant to decay
- UV stabilised and colourfast
- Supplied in 2.4m lengths with a set of eight fixing clips per length

Quality

- Satisfies all NHBC requirements
- Manufactured to BS EN ISO 9001 and BS EN ISO 14001
- Complies with all relevant Building Regulations
- Meets all relevant British Standards

Material and Colour Choice

- Manufactured by extrusion in UPVC
- Available in black only

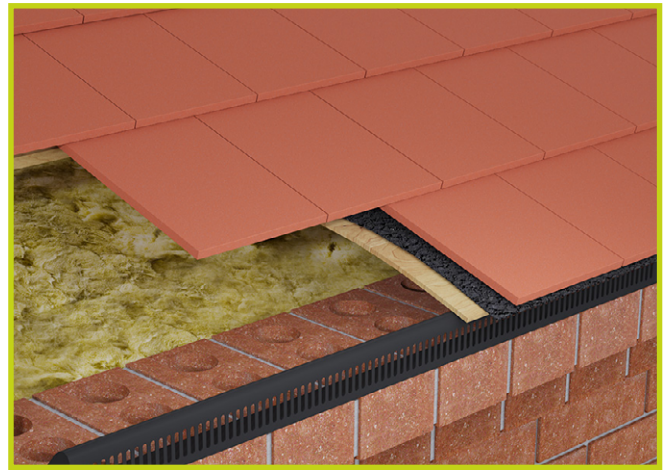
Installation Advice

- Use to ventilate pitched roofs, where the pitch of the roof is 15 degrees or more, and the roof void is attic or loft space
- Do not use to ventilate pitched roofs where the pitch of the roof is less than 15 degrees, flat roofs or any roof where living accommodation is contained within the roof space
- Make sure each ventilator is fixed securely to the top row of corbelling using all eight clips provided
- It is advisable to provide a felt support above the corbel vent. This should project at least 15mm beyond the front of the vent to prevent felt from sagging between the rafters and to maintain a clear air path to the vent front
- Ventilation must be provided for the full length of the eaves and along both sides of the building to create a cross flow ventilation action

Please see technical section for more details.

How to Order

- Measure the overall length of the eaves to be ventilated and divide by 2.4m to determine the number of ventilators required



Bill of Quantity

G20 Carpentry/Timber Framing/First Fixing

Clause

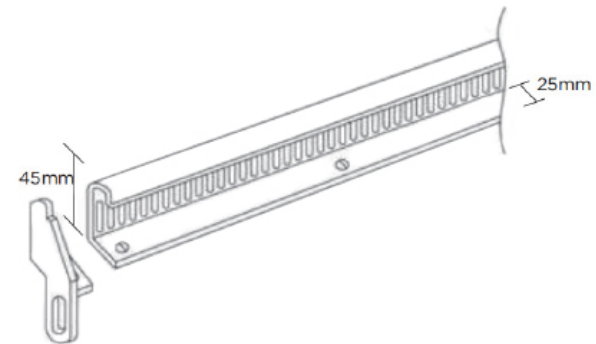
900^ | EAVES SOFFIT VENTILATION

- Manufacturer: Timloc Building Products, Timloc House, Ozone Park, Howden, East Yorkshire, DN14 7SD. T: 01405 765567 W: www.timloc.co.uk
- Product Reference: 3012
- Type: Corbel Ventilator Strip 2.4m
- Colour: Black
- Airway: Provide the equivalent of a continuous opening of not less than 10mm for the full length of eaves.

Product Code

Description	Length	Vent Type	Pack Qty	Product Code
10,000mm ² per meter	2.4m	Slot	10	3012

Product Dimensions



Scan to view the full product page on the Timloc website

Over Fascia Vent

Durable, multi-purpose ventilator

Use

- For roof eaves ventilation
- For flat roof abutment ventilation
- On roofs where the eaves incorporate a fascia board
- On roofs which do not incorporate a soffit board, or where an unbroken soffit board is required

Features and Benefits

- Very unobtrusive and easy to fit
- Superior strength construction - will carry the weight of the bottom row of tiles
- 4mm wide slots comply with BS 5250 : 2021
- Durable and totally resistant to decay
- UV stabilised and colourfast

Quality

- Satisfies all NHBC requirements
- Manufactured to BS EN ISO 9001 and BS EN ISO 14001
- Complies with all relevant Building Regulations
- Meets all relevant British Standards

Material and Colour Choice

- Manufactured by injection moulding in high density polypropylene
- Available in black or white

Products in the System

Over fascia vent - 3011

- Provides ventilation equivalent to a continuous 10mm opening (10,000mm² per metre run). Supplied in 300mm lengths.

Over fascia vent - 3011-25

- Provides ventilation equivalent to a continuous 25mm opening (25,000mm² per metre run). Supplied in 300mm lengths.

Installation Advice

- Use 3011 to ventilate pitched roofs, where the pitch of the roof is 15 degrees or more, and the roof void is attic or loft space
- Use 3011-25 to ventilate pitched roofs, where the pitch of the roof is less than 15 degrees, flat roofs or any roof where living accommodation is contained within the roof space
- Make sure each ventilator is fixed securely into the top of the fascia board using at least three screws or nails per ventilator
- On pitched roofs it is advisable to provide a felt support above the fascia ventilator, projecting at least 10mm beyond the front of the ventilator. This will prevent the felt from sagging behind the fascia board and will maintain a clear air path at the front
- When ventilating flat roof abutments with 3011-25 extra joinery work is essential - please consult the Timloc Technical Department
- Ventilation must be provided for the full length of the eaves and along both sides of the building to create a cross flow ventilation action

Please see technical section for more details.

How to Order

- Determine whether the roof design requires ventilation equivalent to a continuous 10mm opening (3011), or 25mm opening (3011-25)
- Specify which colour is preferred
- Measure the overall length of the eaves to be ventilated and divide by 300mm to determine the number of lengths required



Bill of Quantity

Over fascia ventilator 300mm (25mm airflow)

G20 Carpentry/Timber Framing/First Fixing Clause

910^A EAVES SOFFIT VENTILATION

- Manufacturer: Timloc Building Products, Timloc House, Ozone Park, Howden, East Yorkshire, DN14 7SD. T: 01405 765567 W: www.timloc.co.uk
- Product Reference: 3011
- Type: Over Fascia Ventilator (300mm) 10mm Airflow
- Colour: (Black, White, Brown)
- Airway: Provide the equivalent of a continuous opening of not less than 10mm for the full length of eaves.

Over fascia ventilator 300mm (25mm airflow)

G20 Carpentry/Timber Framing/First Fixing Clause

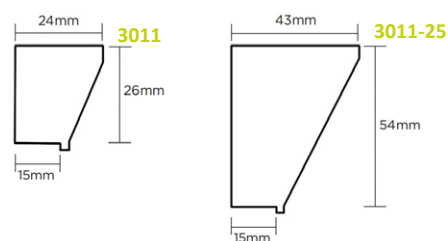
910^A EAVES SOFFIT VENTILATION

- Manufacturer: Timloc Building Products, Timloc House, Ozone Park, Howden, East Yorkshire, DN14 7SD. T: 01405 765567 W: www.timloc.co.uk
- Product Reference: 3011-25
- Type: Over Fascia Ventilator (300mm) 25mm Airflow
- Colour: (Black, White)
- Airway: Provide the equivalent of a continuous opening of not less than 25mm for the full length of eaves.

Product Codes

Free Airflow	Length	Colour	Pack Qty	Product Code
10,000mm ² per meter	300mm	Black	10	3011BL
10,000mm ² per meter	300mm	White	10	3011WH
25,000mm ² per meter	300mm	Black	10	3011/25BL
25,000mm ² per meter	300mm	White	10	3011/25W

Product Dimensions



Scan to view the full product page on the Timloc website

1m Over Fascia Vent

Efficient, durable ventilator in convenient 1m lengths

Use

- For roof eaves ventilation
- For flat roof abutment ventilation
- On roofs where the eaves incorporate a fascia board
- On roofs which do not incorporate a soffit board, or where an unbroken soffit board is required

Features and Benefits

- Efficient, very unobtrusive and easy to fit
- Superior strength construction - will carry the weight of the bottom row of tiles
- 3.5mm - 4mm wide ventilation slots comply with BS 5250 : 2021
- Durable and totally resistant to decay
- UV stabilised and colourfast
- Supplied in convenient 1m lengths

Quality

- Satisfies all NHBC requirements
- Manufactured to BS EN ISO 9001 and BS EN ISO 14001
- Complies with all relevant Building Regulations
- Meets all relevant British Standards

Material and Colour Choice

- Manufactured by injection moulding in polypropylene
- Available in black

Installation Advice

- Use OF1 to ventilate pitched roofs, where the pitch of the roof is 15 degrees or more, and the roof void is attic or loft space
- Use OF2 to ventilate pitched roofs, where the pitch of the roof is less than 15 degrees, flat roofs or any roof where living accommodation is contained within the roof space
- Make sure each ventilator is fixed securely into the top of the fascia board using screws or nails through each fixing hole provided
- On pitched roofs it is advisable to provide a felt support above the fascia ventilator. This will prevent the felt from sagging behind the fascia board and will maintain a clear air path at the front
- When ventilating flat roof abutments with OF2 some extra joinery work is essential - see the illustration above
- Ventilation must be provided for the full length of the eaves and along both sides of the building to create a cross flow ventilation action
- Please see technical section for more details

How to Order

- Determine whether the roof design requires ventilation equivalent to a continuous 10mm opening (OF1) or 25mm opening (OF2)
- Measure the overall length of the eaves to be ventilated and divide by 1m to determine the number of ventilators required



Bill of Quantity

Over fascia ventilator 1000mm (10mm airflow)

G20 Carpentry/Timber Framing/First Fixing
Clause

910^ EAVES SOFFIT VENTILATION

- Manufacturer: Timloc Building Products, Timloc House, Ozone Park, Howden, East Yorkshire, DN14 7SD. T: 01405 765567 W: www.timloc.co.uk
- Product Reference: OF1
- Type: Over Fascia Ventilator (1000mm) 10mm Airflow
- Colour: (Black)
- Airway: Provide the equivalent of a continuous opening of not less than 10mm for the full length of eaves.

Over fascia ventilator 1000mm (25mm airflow)

G20 Carpentry/Timber Framing/First Fixing
Clause

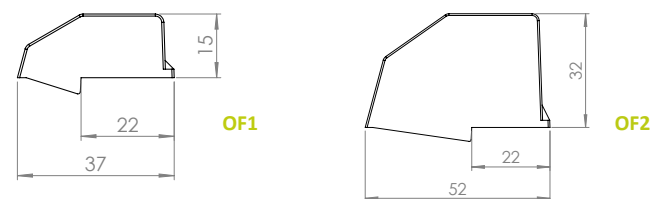
910^ EAVES SOFFIT VENTILATION

- Manufacturer: Timloc Building Products, Timloc House, Ozone Park, Howden, East Yorkshire, DN14 7SD. T: 01405 765567 W: www.timloc.co.uk
- Product Reference: OF2
- Type: Over Fascia Ventilator (1000mm) 25mm Airflow
- Colour: (Black)
- Airway: Provide the equivalent of a continuous opening of not less than 25mm for the full length of eaves.

Product Codes

Description	Free Airflow	Length	Colour	Pack Qty	Product Code
1m Over Fascia Vent	10,000mm ²	1m	Black	25	OF1BL
1m Over Fascia Vent	25,000mm ²	1m	Black	20	OF2BL

Product Dimensions



Scan to view the full product page on the Timloc website

Over Fascia Ventilation System

Efficient multi-functional ventilation system

Use

- For roof eaves ventilation
- On roofs where the eaves incorporate a fascia board
- On roofs which do not incorporate a soffit board or where an unbroken soffit board is required

Features and Benefits

- Provides ventilation equivalent to a continuous 10mm opening (10,000mm² per metre run) and is supplied in 1m lengths.
- Efficient, very unobtrusive and easy to fit
- Superior strength construction - will carry the weight of the bottom row of tiles
- Performs several functions in a single product - over fascia ventilator, felt support/eaves protector and eaves comb filler
- 4mm wide ventilation slots comply with BS 5250 : 2021
- Durable and totally resistant to decay
- UV stabilised and colourfast
- Supplied in convenient effective 1m lengths

Quality

- Satisfies all NHBC requirements
- Manufactured to BS EN ISO 9001 and BS IN ISO 14001
- Complies with all relevant Building Regulations
- Meets all relevant British Standards

Material and Colour Choice

- Manufactured by injection moulding in high density polypropylene
- Available in black only

Installation Advice

- Use to ventilate pitched roofs, where the pitch of the roof is 15 degrees or more, and the roof void is attic or loft space
- Make sure each ventilator is fixed securely into the top of the fascia board using screws or nails through the fixing holes provided
- Products designed so that the roofing felt will be cut back flush with the edge of the fascia board, and not dressed out into the gutter
- Ventilation must be provided for the full length of the eaves and along both sides of the building to create a cross flow ventilation action

Please see technical section for more details.

How to Order

- Specify product code with C if integral eaves comb filler is needed
- Measure the overall length of the eaves to be ventilated and divide by 1000mm to determine the number of ventilators required

Bill of Quantity

Over fascia ventilation system 1m (10mm airflow)

G20 Carpentry/Timber Framing/First Fixing
Clause

910^ EAVES SOFFIT VENTILATION

- Manufacturer: Timloc Building Products, Timloc House, Ozone Park, Howden, East Yorkshire, DN14 7SD. T: 01405 765567 W: www.timloc.co.uk
- Product Reference: 3014C or 3014
- Type: Over Fascia Ventilation System (1000mm) 10mm Airflow
- Colour: Black
- Airway: Provide the equivalent of a continuous opening of not less than 10mm for the full length of eaves.

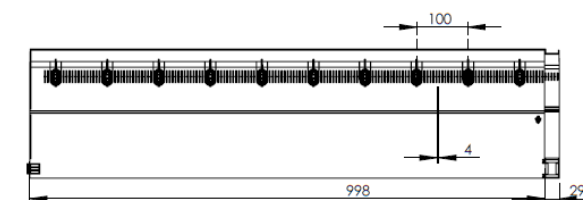
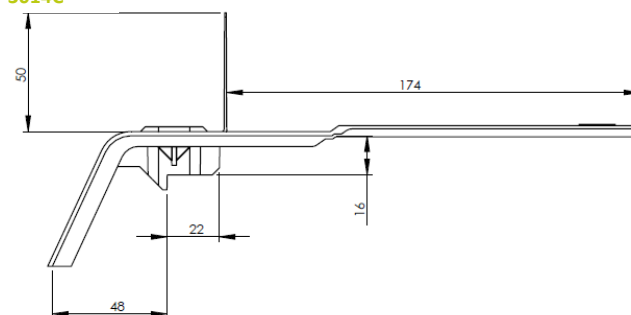


Product Codes

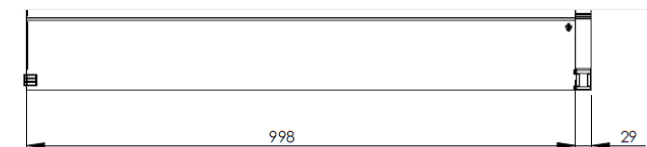
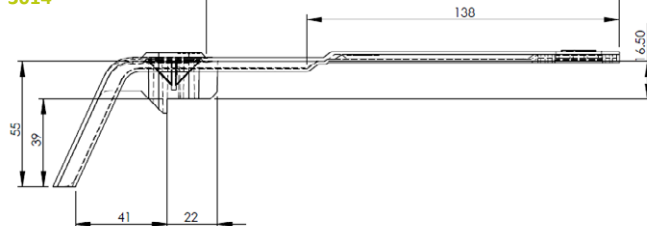
Free Airflow	Length	Eaves Comb	Pack Qty	Product Code
10,000mm ² per meter	1m	Yes	10	3014C
10,000mm ² per meter	1m	No	20	3014

Product Dimensions

3014C



3014



Scan to view the full product page
on the Timloc website

Rafter Roll

Roll out system to maintain ventilation between insulation and roofing felt

Use

- For pitched roof eaves ventilation
- On standard pitched roofs where the pitch is 15 degrees or more and the roof void is an attic or loft space
- On roofs with rafter spacings of between 400mm and 600mm centres

Features and Benefits

- Durable, totally resistant to decay, easy to fit
- Supplied in convenient 6m rolls
- Suitable for new build and refurbishment projects

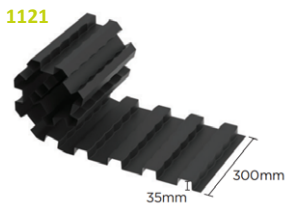
Quality

- Satisfies all NHBC requirements
- Manufactured to BS EN ISO 9001 and BS IN ISO 14001
- Complies with all relevant Building Regulations
- Meets all relevant British Standards

Material and Colour Choice

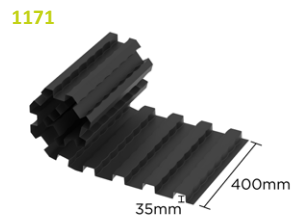
- Manufactured by vacuum forming in RPET
- Available in black only

Products in the System



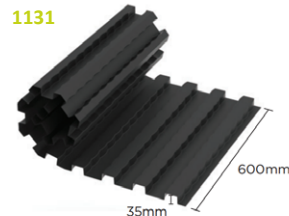
1121
300mm roll form eaves vent
Single row of 300mm roll panel coverage suitable for:

Insulation depth	Min roof pitch °
225mm	40°
250mm	45°



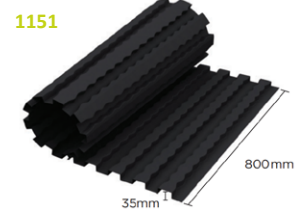
1171
400mm roll form eaves vent
Single row of 400mm roll panel coverage suitable for:

Insulation depth	Min roof pitch °
225mm	32.5°
250mm	37.5°
300mm	48.5°



1131
600mm roll form eaves vent
Single row of 600mm roll panel coverage suitable for:

Insulation depth	Min roof pitch °
225mm	20°
250mm	22.5°
300mm	27.5°
400mm	37.5°



1151
800mm roll form eaves vent
Single row of 800mm roll panel coverage suitable for:

Insulation depth	Min roof pitch °
225mm	17.5°
250mm	20°
300mm	22.5°
400mm	30°



Installation Advice

- Unroll the ventilator along the rafters along the full length of the eaves and along both sides of the building to create a cross flow ventilation action
- Position centrally above the wall plate. This is the narrowest part of the roof where the roof insulation is most likely to constrict the airflow
- Push the corrugations down over the top of the rafters and secure using clout nails or staples

How to Order

- Measure the overall length of the eaves to be ventilated and divide by 6m to determine the number of rolls of ventilator required

Product Codes

Depth of ventilation channel	Width	Length	Pack Qty	Product Code
>35mm	300mm	6m	10	1121
>35mm	400mm	6m	12	1171
>35mm	600mm	6m	5	1131
>35mm	800mm	6m	6	1151



Scan to view the full product page on the Timloc website

6m Eaves Vent Pack

Easy-to-fit ventilation system in one pack

Use

- For pitched roof eaves ventilation
- On standard pitched roofs
- On roofs with rafter spacings of between 400mm and 600mm

Features and Benefits

- Efficient and easy to fit
- Durable and totally resistant to decay
- Complete eaves ventilation in a single pack

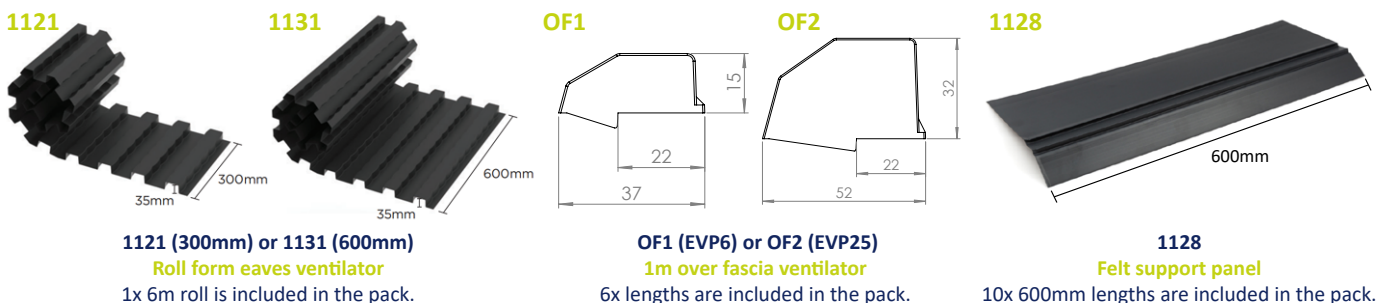
Quality

- Satisfies all NHBC requirements
- Manufactured to BS EN ISO 9001 and BS EN ISO 14001
- Complies with all relevant Building Regulations
- Meets all relevant British Standards

Material and Colour Choice

- Over fascia ventilators are manufactured by injection moulding in polypropylene. Roll form eaves vent by vacuum forming in RPET and felt support panels extruded in UPVC
- Available in black only

Products in the System



Compatibility

EVP6/600 & EVP6/25600

Single row of 600mm roll coverage suitable for:

Insulation depth	Min roof pitch °
100mm	17.5°
150mm	25°
200mm	35°
225mm	40°
250mm	45°

EVP6 & EVP6/25

Single row of 300mm roll coverage suitable for:

Insulation depth	Min roof pitch °
100mm	10°
200mm	17.5°
225mm	20°
250mm	22.5°
270mm	25°
300mm	27.5°
350mm	32.5°
400mm	37.5°

Installation Advice

Roll form eaves vents

- Unroll the ventilator along the rafters along the full length of the eaves. Position centrally above the wall plate. This is the narrowest part of the roof where the roof insulation is most likely to constrict the airflow. Push the corrugations down over the top of the rafters and secure using clout nails or staples.

Over fascia vents

- Fix ventilators to the top edge of the fascia board using screws or nails through the fixing holes provided. Ventilation must be provided for the full length of the eaves and along both sides of the building to create a cross flow ventilation action. Felt support trays fit directly on top of the over fascia vent. Secure with clout nails driven into the top of the fascia board through the slots in the over fascia vent. Ensure each panel is allowed to overlap the next. Allow the rear of the panel to lay back on to the rafters.

How to Order

- Measure the overall length of the eaves to be ventilated and divide by 6m to determine the number of packs required.

Product Codes

Free Airflow	Roll Form Width	Length	Product Code
10,000mm ² per meter	300mm	6m	EVP6
25,000mm ² per meter	300mm	6m	EVP6/25
10,000mm ² per meter	600mm	6m	EVP6/600
25,000mm ² per meter	600mm	6m	EVP6/25600

NB. EVP6-25 contains a 25mm deep roll form eaves vent not 50mm.



Scan to view the full product page on the Timloc website

Felt Support Tray

Designed to prevent damage to roofing felt

Use

- At the eaves of a roof to support and protect roofing felt
- For remedial work to replace worn or perished roofing felt

Features and Benefits

- Effective, quick and easy to fit
- Improves performance of other roofing materials
- Ideal for remedial work
- Durable and totally resistant to decay
- Supplied in convenient 1.5m lengths or 600mm

Quality

- Satisfies all NHBC requirements
- Manufactured to BS EN ISO 9001 and BS EN ISO 14001
- Complies with all relevant Building Regulations
- Meets all relevant British Standards

Material and Colour Choice

- Extruded in UPVC
- Available in black/dark grey

Installation Advice

- Fit on the top of the fascia board below roofing felt, allowing a 150mm overlap where pieces join
- Secure with clout nails and fold back the rear flap to rest on the rafters

How to Order

- Measure the overall length of the eaves to be protected and divide by 1.35m to determine the number of protectors required or 450mm (1128)



Bill of Quantity

G20 Carpentry/Timber Framing/First Fixing

Clause

900^ EAVES SOFFIT VENTILATION

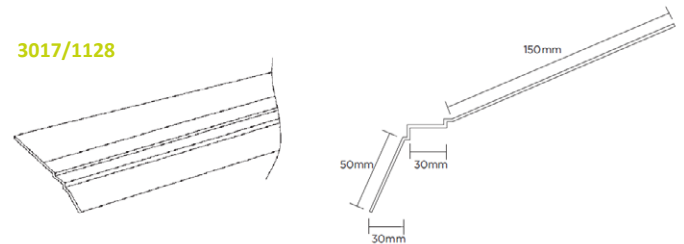
- Manufacturer: Timloc Building Products, Timloc House, Ozone Park, Howden, East Yorkshire, DN14 7SD. T: 01405 765567 W: www.timloc.co.uk
- Product Reference: 3017
- Type: Protector (1500mm)
- Colour: Black

Product Codes

Description	Pack Quantity	Product Code
Felt support tray 1500mm	10	3017
Felt support tray 600mm	20	1128

Product Dimensions

3017/1128



Scan to view the full product page on the Timloc website

Eaves Comb Filler

Designed to prevent entry of birds and vermin below profiled roof tiles

Use

- At the eaves of a roof
- Below profiled roof tiles to exclude birds and vermin

Features and Benefits

- Effective, quick and easy to fit
- Durable and totally resistant to decay
- Supplied in convenient 1m lengths

Quality

- Satisfies all NHBC requirements
- Manufactured to BS EN ISO 9001 and BS EN ISO 14001
- Complies with all relevant Building Regulations
- Meets all relevant British Standards

Material and Colour Choice

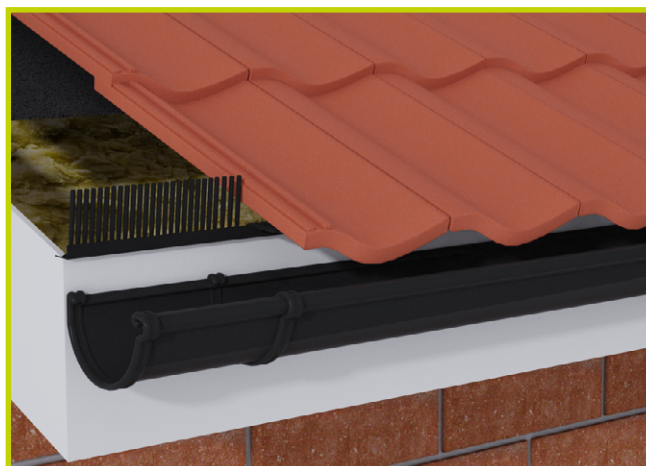
- Injection moulded in polypropylene
- Available in black only

Installation Advice

- Fit on the top of the fascia board before tiles are laid. The comb must angle outwards away from the roof
- Secure with clout nails through the holes provided
- Bed bottom row of tiles on to the comb

How to Order

- Measure the overall length of the eaves and divide by 1m to determine the number of combs required



Bill of Quantity

G20 Carpentry/Timber Framing/First Fixing

Clause

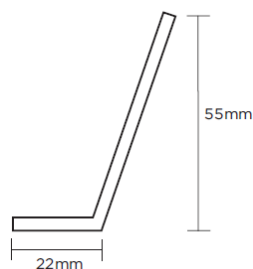
900^ EAVES SOFFIT VENTILATION

- Manufacturer: Timloc Building Products, Timloc House, Ozone Park, Howden, East Yorkshire, DN14 7SD. T: 01405 765567 W: www.timloc.co.uk
- Product Reference: 1136
- Type: Eaves Comb Filler (1000mm)
- Colour: Black

Product Codes

Depth of Comb	Length	Pack Quantity	Product Code
55mm	1m	50	1136

Product Dimensions

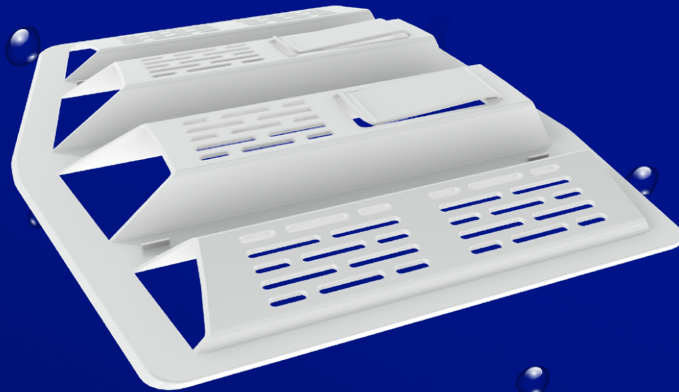


Scan to view the full product page on the Timloc website

Cooler temperatures increase the risk of

CONDENSATION

in the loft space



SOLVE IT
with

LAP VENT

A remedial solution for combating condensation in cold roof voids by separating lap joints in the roofing felt/membrane and can be fitted retrospectively after increased loft insulation.

Scan to view



install video

Lap Vent

Refurbishment ventilator for existing roof spaces

Use

- To increase the level of ventilation in a roof space by separating lap joints in the roofing felt/membrane.
- Remedial solution for combating condensation in cold roof voids
- Can be fitted retrospectively after increased loft insulation

Features and Benefits

- Discrete profile design
- Easy installation
- 2 spring clips to secure each unit in place

Technical Information

- 3000mm² additional free vent area per unit
- Suitable for rafter spacings from 400-600mm centres
- Designed only to enhance existing ventilation via felt/membrane lap joints
- Consideration must be given to increased risk of wind uplift and driving rain resistance outlined in BS5534:2014

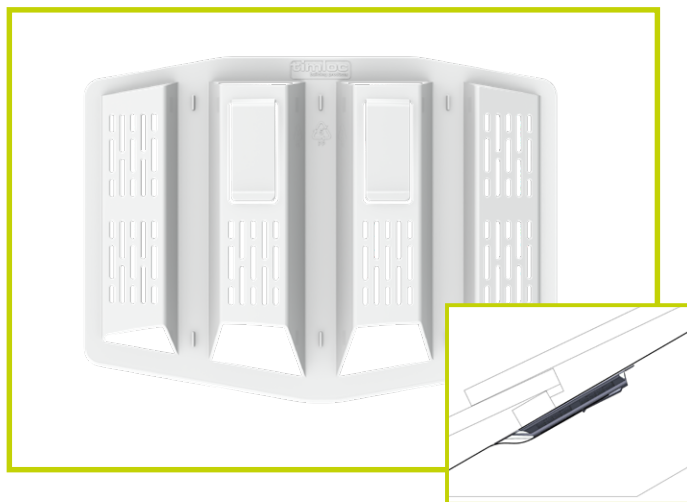
Quality

- Manufactured to British Standards: BS EN 9001 and BS EN 14001

Installation Advice

- Allowing ventilation between roofing felt/membranes is secondary to eaves and/or ridge ventilation
- Lap vent simply slots between roof felt/membranes laps
- Position the lap vent clips facing down to hang on the edge of the roofing felt/membrane when in position
- Install one lap vent into every alternate rafter space at low level
- If further ventilation is required, install one lap vent into every rafter space at low level and/or into lap joints at higher levels
- The lap vents should be fitted to both sides of the roof space in order to provide cross-flow ventilation
- Installing lap vents alone will not meet minimum roof ventilation requirements. For guidance and regulations on roof space ventilation please refer to British Standard BS5250

N.B. By specifying the lap vent, you acknowledge that the wind uplift loads on the tiles/slates and driving rain resistance of the membrane can be adversely affected



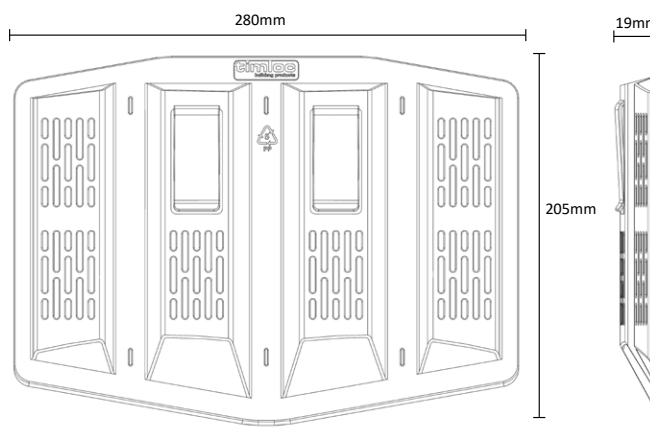
Material and Colour Choice

- Injection Moulded recycled Polypropylene
- Off-white

How to Order

- Calculate quantity of lap vents based on the level of ventilation required
- For typical installation allow 1 lap vent per alternate rafter spacing at low level
- Increase ventilation by allowing additional lap vents at high level
- For maximum ventilation allow lap vents to every rafter spacing

Product Dimensions



Product Code

Airflow	Colour	Pack Quantity	Product Code
3000mm ²	Off-white	10	5560



Scan to view the full product page on the Timloc website

6m Roll Out Dry Fix Ridge Kit

Convenient mechanical fix solution for roof ridge installations

Use

- Most types of slate, concrete or clay roof tiles
- Round or angled ridge tiles
- Most pitched roof types from 15-55°
- New build and retro-fit projects

Features and Benefits

- Preassembled fixing screws and clamping plates
- Ridge union with adjustable clip positions for ridge tile upto 18mm thickness
- Universal ridge batten strap for ease and flexibility
- Long lasting, reliable and virtually maintenance free
- Protects against wind uplift, water ingress and general deterioration
- Provides 5000mm²/m (5mm continuous) ridge ventilation
- Easy, fast, clean and generally safer mortar free installation
- Water resistant yet air permeable membrane roll
- Strong, malleable and corrosion resistant aluminium flashing secured to roll
- 55mm wide ridge union width provides additional water bar protection
- Assurance of stainless steel clamping plates
- Maintains consistently smart appearance
- Not impacted by building settlement
- Helps prevent entry of large insects, birds and vermin into the roofline

Quality

- Helping to meet:
 - BS 5534 Code of practice for slating and tiling
 - BS 5250 Code of practice for control of condensation in buildings
- Complies with all other relevant regulations and standards
- Independently tested and complies with BS 8612

Material and Colour Choice

- Ridge unions and clips manufactured from UV protected and colour fast polypropylene
- Water resistant and ventilated roll membrane with attached self-adhesive and coloured aluminium flashing (colour may vary from pictured)
- Galvanised steel ridge batten straps
- Stainless steel screws and clamping plates
- Available in Black
- All kits are supplied with black ridge unions and clips

Installation Advice

- Please refer to timloc.co.uk for recommended installation guidance



Components Supplied in the Pack

- 1 x 6m vent roll membrane with self-adhesive flashing
- 13 x fixing screws and clamping plates
- 13 x ridge unions
- 26 x ridge union clips
- 10 x ridge batten straps

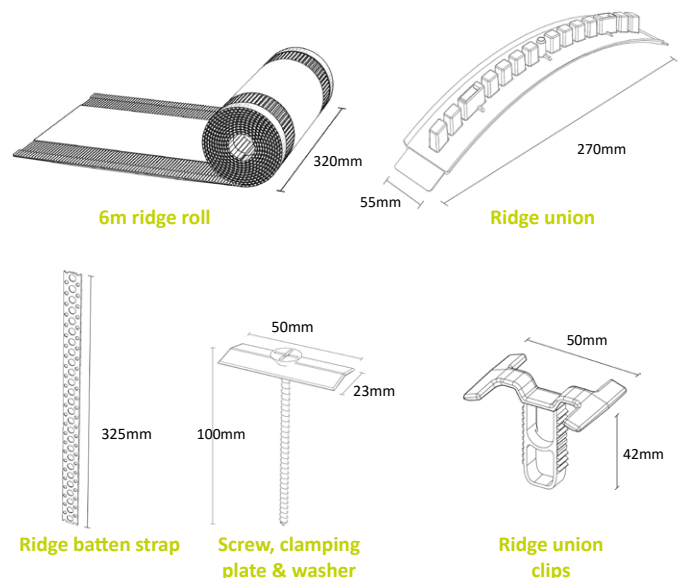
How to Order

- Select the relevant 6m roll out dry fix ridge kit colour for the project
- Order 1 pack for roof ridge lengths up to 6m
- Sequential packs can be installed
- Please allow for a minimum roll membrane overlap of at least 150mm

Product Codes

Depth of Comb	Colour	Product Code
6m roll out dry fix ridge kit	Black	54700
13x ridge unions & 26x ridge clips	Black	54618
13x fixing screws & clamping plates	N/A	54626

Product Dimensions



Scan to view the full product page on the Timloc website

3m | 6m | 10m Integrated Dry Ridge Kit

Convenient mechanical fix solution for roof ridge installation

Use

- Most types of slate, concrete or clay roof tiles
- Round or angled ridge tiles
- Most pitched roof types from 15-55°
- New build and retro-fit projects

Features and Benefits

- Fixing screws, washers and clamping plates
- Ridge union with integrated clips compatible with ridge tiles up to 18mm thickness
- Universal ridge batten strap for ease and flexibility
- Long lasting, reliable and virtually maintenance free
- Protects against wind uplift, water ingress and general deterioration
- Provides 5000mm²/m (5mm continuous) ridge ventilation
- Easy, fast, clean and generally safer mortar free installation
- Water resistant yet air permeable membrane roll
- Strong, malleable and corrosion resistant aluminium flashing secured to roll
- 55mm wide ridge union provides additional water bar protection
- Assurance of stainless steel clamping plates
- Maintains consistently smart appearance
- Not impacted by building settlement
- Helps prevent entry of large insects, birds and vermin into the roofline

Quality

- Helping to meet:
 - BS 5534 Code of practice for slating and tiling
 - BS 5250 Code of practice for control of condensation in buildings
- Complies with all other relevant regulations and standards
- Independently tested and complies with BS 8612

Material and Colour Choice

- Ridge unions manufactured from UV protected and colour fast polypropylene
- Water resistant and ventilated roll membrane with attached self-adhesive and black aluminium flashing (colour may vary from pictured)
- Galvanised steel ridge batten straps
- Stainless steel screws and clamping plates
- Available in black only

Installation Advice

- Please refer to timloc.co.uk for recommended installation guidance

How to Order

- Order 1 pack per roof ridge length of 3m, 6m or 10m
- Sequential packs can be installed together
- Please allow for a minimum roll overlap of at least 150mm



Components Supplied in the Pack

3m Integrated Dry Ridge Kit

- 1 x 3m vent roll membrane with self-adhesive flashing
- 7 x fixing screws, washers and clamping plates
- 7 x ridge unions with integrated clips
- 5 x ridge batten straps

6m Integrated Dry Ridge Kit

- 1 x 6m vent roll membrane with self-adhesive flashing
- 13 x fixing screws, washers and clamping plates
- 13 x ridge unions with integrated clips
- 10 x ridge batten straps

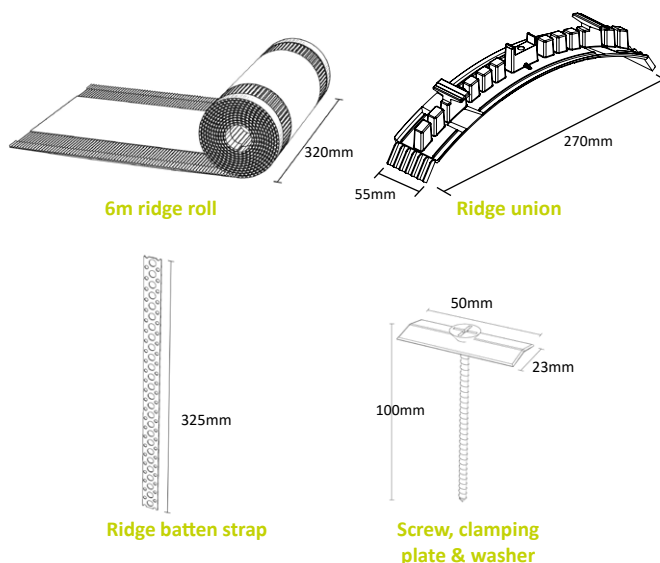
10m Integrated Dry Ridge Kit

- 1 x 10m vent roll membrane with self-adhesive flashing
- 26 x fixing screws, washers and clamping plates
- 26 x ridge unions with integrated clips
- 20 x ridge batten straps

Product Codes

Depth of Comb	Colour	Product Code
3m roll out dry fix ridge kit	Black	53700
6m roll out dry fix ridge kit	Black	54703
10m roll out dry fix ridge kit	Black	51700

Product Dimensions



Scan to view the full product page on the Timloc website

6m Roll Out Dry Fix Clay Ridge Kit

Convenient mechanical fix solution for clay roof ridge installations

Use

- Most types of clay roof tiles
- Round or angled ridge tiles
- Most pitched roof types from 15-55°
- New build and retro-fit projects

Features and Benefits

- Preassembled fixing screws and clamping plates
- Ridge union with adjustable clip positions to suit a range of clay ridge tile thicknesses (30mm max)
- Universal ridge batten strap for ease and flexibility
- Long lasting, reliable and virtually maintenance free
- Protects against wind uplift, water ingress and general deterioration
- Provides 5000mm²/m (5mm continuous) ridge ventilation
- Easy, fast, clean and generally safer mortar free installation
- Water resistant yet air permeable membrane roll
- Strong, malleable and corrosion resistant aluminium flashing secured to roll
- 55mm wide ridge union width provides additional water bar protection
- Assurance of stainless steel clamping plates
- Maintains consistently smart appearance
- Not impacted by building settlement
- Helps prevent entry of large insects, birds and vermin into the roofline

Quality

- Helping to meet:
 - BS 5534 Code of practice for slating and tiling
 - BS 5250 Code of practice for control of condensation in buildings
- Complies with all other relevant regulations and standards
- Independently tested and complies with BS 8612

Material and Colour Choice

- Ridge unions and clips manufactured from UV protected and colour fast polypropylene
- Water resistant and ventilated roll membrane with attached self-adhesive and coloured aluminium flashing (colour may vary from pictured)
- Galvanised steel ridge batten straps
- Stainless steel screws and clamping plates
- Available in black only
- All kits are supplied with black ridge unions and clips

Installation Advice

- Please refer to timloc.co.uk for recommended installation guidance



Components Supplied in the Pack

- 1 x 6m vent roll membrane with self-adhesive flashing
- 20 x fixing screws and clamping plates
- 20 x ridge unions
- 40 x ridge union clips
- 10 x ridge batten straps

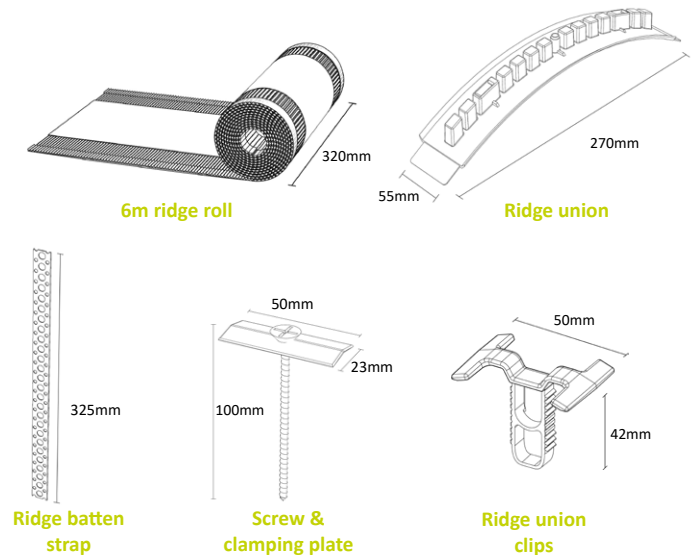
How to Order

- Order 1 pack for roof ridge lengths up to 6m
- Order further kits to cover lengths over 6m. These can be installed sequentially
- Please allow for a minimum roll membrane overlap of at least 150mm

Product Codes

Depth of Comb	Colour	Product Code
6m roll out dry fix clay ridge kit	Black	54713
20x ridge unions & 40x ridge clips	Black	54715
20x fixing screws & clamping plates	Silver	54716

Product Dimensions



Scan to view the full product page on the Timloc website

6m Roll Out Dry Fix Hip Kit

Convenient mechanical fix solution for roof hip installations

Use

- Most types of slate, concrete or clay hip tiles
- Round or angled hip tiles
- Most pitched roof types from 15-55°
- New build and retro-fit projects

Features and Benefits

- Preassembled fixing screws and clamping plates
- Ridge union with adjustable clip positions for ridge tile thickness
- Universal ridge batten strap for ease and flexibility
- Long lasting, reliable and virtually maintenance free
- Protects against wind uplift, water ingress and general deterioration
- Provides 5000mm²/m (5mm continuous) ridge ventilation
- Easy, fast, clean and generally safer mortar free installation
- Water resistant yet air permeable membrane roll
- Strong, malleable and corrosion resistant aluminium flashing secured to roll
- 55mm wide ridge union width provides additional water bar protection
- Assurance of stainless steel clamping plates
- Maintains consistently smart appearance
- Not impacted by building settlement
- Helps prevent entry of large insects, birds and vermin into the roofline

Quality

- Helping to meet:
 - BS 5534 Code of practice for slating and tiling
 - BS 5250 Code of practice for control of condensation in buildings
- Complies with all other relevant regulations and standards
- Independently tested and complies with BS 8612

Material and Colour Choice

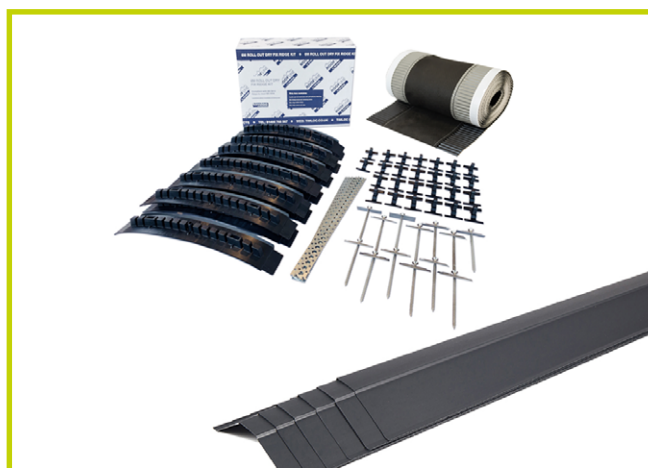
- Ridge unions & clips manufactured from UV protected & colour fast polypropylene
- Water resistant and ventilated roll membrane with attached self-adhesive aluminium flashing (colour may vary from pictured)
- Galvanised steel ridge batten straps
- Stainless steel screws and clamping plates
- Available in Black
- All kits are supplied with black ridge unions and clips
- Hip trays recycled PVC - black

Installation Advice

- Please refer to timloc.co.uk for recommended installation guidance

Components Supplied in the Pack

- 1 x 6m vent roll membrane with self-adhesive flashing
- 13 x fixing screws and clamping plates
- 13 x ridge unions
- 26 x ridge union clips
- 10 x ridge batten straps
- 6 x hip trays



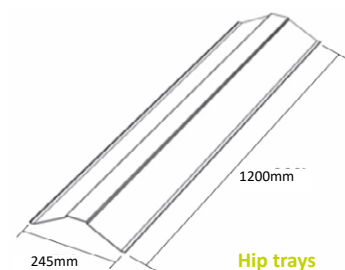
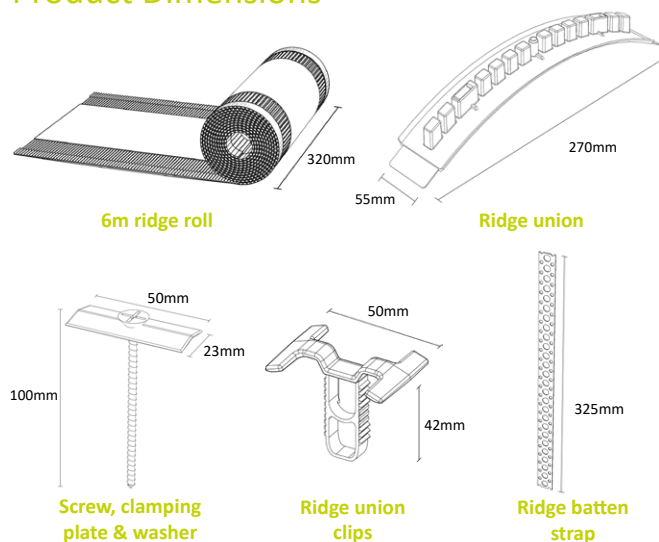
How to Order

- Select the relevant 6m roll out dry fix hip kit colour for the project
- Order 1 pack for roof hip lengths up to 6m
- Sequential packs can be installed
- Please allow for a minimum roll membrane overlap of at least 150mm
- Allow for minimum hip tray overlap of at least 150mm

Product Codes

Depth of Comb	Colour	Product Code
6m roll out dry fix hip kit	Black	54710
6x dry fix hip tray only pack	Black	44623
13x ridge unions & 26x ridge clips	Black	54618
13x fixing screws & clamping plates	N/A	54626

Product Dimensions



Scan to view the full product page on the Timloc website

Hip Accessory Kit

Convenient hip accessory kit for roof hip installations.

Use

- Most types of slate, concrete or clay hip tiles
- Round or angled hip tiles
- Most pitched roof types from 15-55°
- New build and retro-fit projects

Features and Benefits

- Maintains consistently smart appearance
- Universal clips to secure small tile cuts to be mechanically fixed at hips
- Long lasting, reliable and virtually maintenance free
- Protects against wind uplift, water ingress and general deterioration
- Easy, fast, clean and generally safer mortar free installation
- Can be installed in virtually all wet and cold weather conditions
- Not impacted by building settlement

Quality

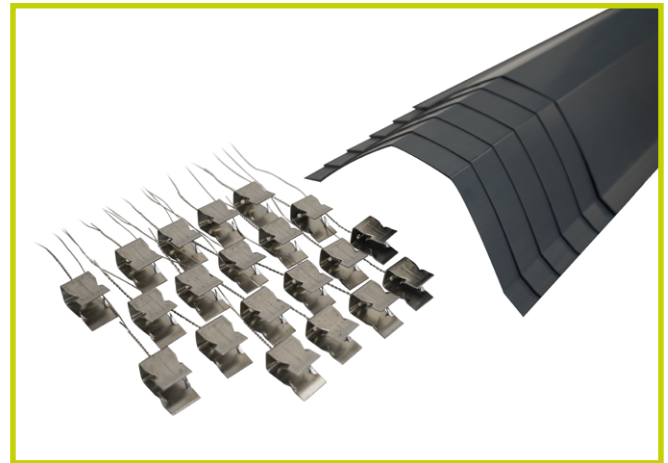
- Helping to meet:
 - BS 5534:2014 Code of practice for slating and tiling
 - BS 5250:2021 Code of practice for control of condensation in buildings

Material and Colour Choice

- Recycled PVC hip trays
- Available in black only
- Stainless steel hip clips

Components Supplied in the Pack

- 6 x 1.2m hip trays
- 20 x hip clips



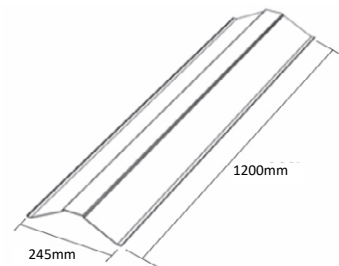
How to Order

- To be used in conjunction with the 6m Roll Out Dry Fix Ridge Kit
- Sequential packs can be installed

Product Codes

Depth of Comb	Colour	Product Code
Hip accessory kit	Black	44629

Product Dimensions



Scan to view the full product page on the Timloc website

DRY FIX VERGE

AMBI-VERGE



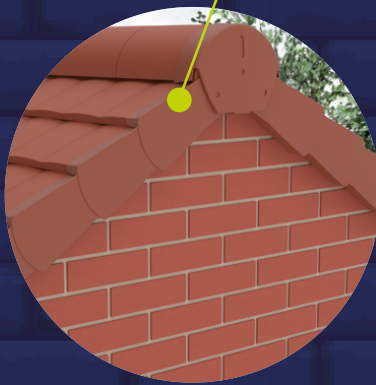
HANDED VERGE



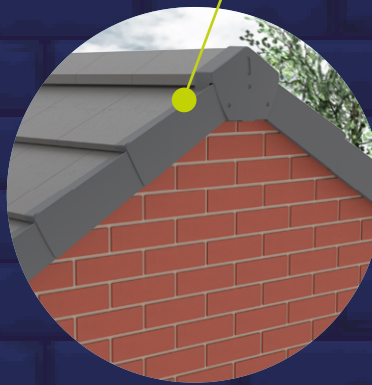
CONTINUOUS VERGE



INTERLOCKING PLAIN



THIN LEADING EDGE



UNIVERSAL RIDGE CAPS

compatible with:

AMBI-VERGE
HANDED VERGE
INTERLOCKING PLAIN
THIN LEADING EDGE

AMBI-VERGE

Non-handed dry verge for universal (L&R) fixing

P. 102

HANDED

Handed dry verge profiled for left or right fixing

P. 104

INTERLOCKING PLAIN

Non-handed dry verge profiled for Interlocking Plain tiles

P. 106

THIN LEADING EDGE

Handed dry verge profiled for Thin Leading Edge tiles

P. 108

CONTINUOUS

Continuous dry verge for slate or flat tile roofs

P. 110

Ambi-Verge Universal Dry Fix Verge System for Profiled Roof Tiles

A robust, attractive and weather resistant verge system alternative to wet mortar bedding

Use

- Large format and interlocking concrete profiled tiles
- Most pitched roof types from 15-55°
- Verges with or without bargeboards
- New build and refurbishment projects

Features and Benefits

- Universal installation – LH & RH sides are interchangeable.
- Long lasting, reliable and virtually maintenance free.
- Protects against wind uplift, water ingress & general deterioration.
- Easy, fast, clean and generally safer mortar free installation.
- Allows virtually all weather installation.
- Strong but supple for easy flexing and sliding along the tiles.
- Secure fit around the tile reassurance.
- Maintains consistently smart appearance.
- Not impacted by building settlement.
- Meets mechanical fix legislation requirements.
- The system also offers a unique steel fixing bracket option that presents flexible fixing points for use with alternative size counter battens or straight onto tile batten ends. The bracket avoids the reliance of end grain fixing, which can cause splitting and consequential damp penetration issues.

Quality

- Helping to meet BS 5534 Code of practice for slating and tiling
- Complies with all other relevant regulations and standards
- Manufactured to BS EN ISO 9001 and BS EN ISO 14001
- Independently tested and complies with BS8612

Material and Colour Choice

- UV protected and colour fast polypropylene
- Galvanised steel batten end bracket (optional)
- Available in grey, terracotta, brown and black

Installation Advice

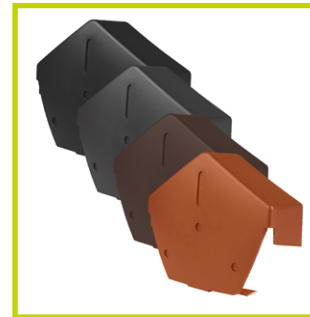
- Please refer to timloc.co.uk for full recommended installation guidance

Products in the System

- Universal verge unit
- Eaves starter
- Half round ridge (apex) end cap
- Angled ridge (apex) end cap
- End grain batten bracket (optional)

How to Order

- Select the relevant verge system colour for the project.
- 1 verge piece is required for each roof tile in the sloping run.
- Select the ridge shape for the apex of the system – angled or round.
- Eaves starter must be installed at the beginning of each sloping run.
- 1 optional end grain batten bracket is required for each verge piece installed in the sloping run



Universal Dry Fix Half Round Ridge End Cap



Universal Dry Fix Angled Ridge End Cap



Ambi-Verge Eaves Starter



End Grain Batten Bracket

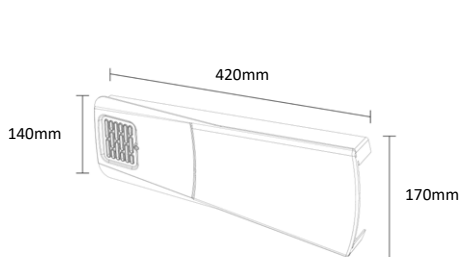


Scan to view the full product page on the Timloc website

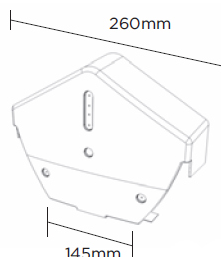
Ambi-Verge Universal Dry Fix Verge System for Profiled Roof Tiles

A robust, attractive and weather resistant verge system alternative to wet mortar bedding

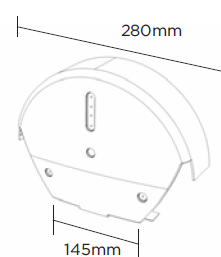
Product Dimensions



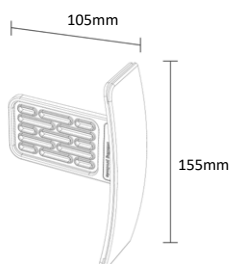
Ambi-Verge universal dry fix verge



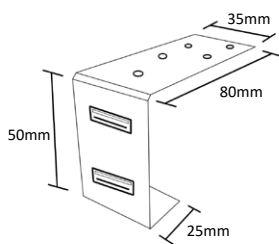
Universal dry fix angled ridge end cap



Universal dry fix half round ridge end cap



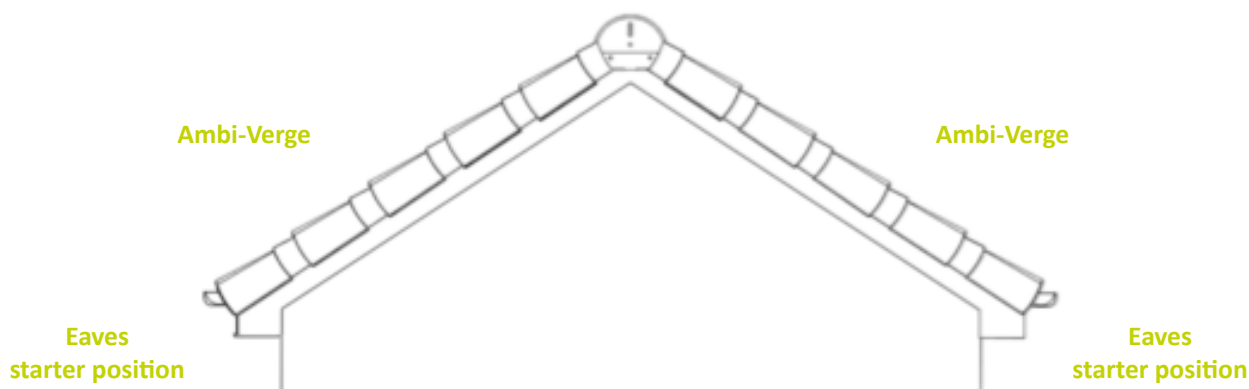
Ambi-Verge eaves starter



End grain batten bracket

Product Detail

Ridge piece (half round or angled)



Product codes

Description	Pack Qty	Grey Product Codes	Brown Product Codes	Black Product Codes	Terracotta Product Codes
Ambi-Verge universal dry fix verge	20	99141	99142	99143	99144
Universal dry fix angled ridge end cap	10	99109	99108	99107	99110
Universal dry fix half round ridge end cap	10	99113	99112	99136	99114
Ambi-Verge eaves starter	1	99153	99155	99154	99156
Dry verge profiled tile end grain batten bracket (optional)	20	99124	99124	99124	99124

Handed Dry Fix Verge System for Profiled Roof Tiles

A robust, attractive and weather resistant verge system alternative to wet mortar bedding

Use

- Large format, interlocking concrete and clay profiled tiles
- Batten gauges between 260-345mm
- Most pitched roof types from 15-55°
- Verges with or without bargeboards
- New build and refurbishment projects

Features and Benefits

- Long lasting, reliable and virtually maintenance free
- Protects against wind uplift, water ingress and general deterioration
- Easy, fast, clean and generally safer mortar free installation
- Allows virtually all weather installation
- Extended slotted fixing locator flexibility
- Simple and quick '1st piece' eaves closer installation
- Strong but supple for easy flexing and sliding along the tiles
- Secure fit around the tile reassurance
- Rebated eaves closer design allows for guttering when required
- Maintains consistently smart appearance
- Not impacted by building settlement
- Helps prevent entry of large insects, birds and vermin into the roofline
- Meets mechanical fix legislation requirements
- The system also offers a unique steel fixing bracket option that presents flexible fixing points for use with alternative size counter battens or straight onto tile batten ends. The bracket avoids the reliance of end grain fixing, which can cause splitting and consequential damp penetration issues.

Quality

- Helping to meet BS 5534 Code of practice for slating and tiling
- Complies with all other relevant regulations and standards
- Manufactured to BS EN ISO 9001 and BS EN ISO 14001
- Independently tested and complies with BS8612

Material and Colour Choice

- UV protected, colour fast polypropylene
- Galvanised steel batten end bracket (optional)
- Available in grey, terracotta, brown and black

Installation Advice

- Please refer to timloc.co.uk for full installation guidance

Products in the System

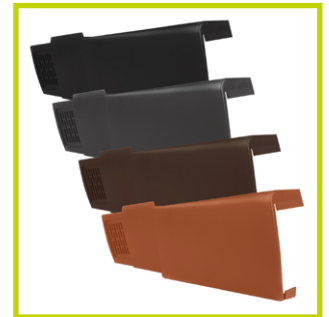
- Dry fix verge right hand piece
- Dry fix verge left hand piece
- Eaves starter pack L&R
- Universal dry fix half round ridge end cap
- Universal dry fix angled ridge end cap
- End grain batten bracket (optional)

How to Order

- Select the relevant verge system colour for the project
- 1 verge piece is required for each roof tile in the sloping run
- Verge pieces are handed to suit left and right handed slopes
- Select the ridge shape for the apex of the system – angled or round
- Eaves closer must be installed at the beginning of each sloping run of dry verge
- 1 optional end grain batten bracket is required for each verge piece installed in the sloping run



**Dry Fix Verge
Right Hand Piece**



**Dry Fix Verge
Left Hand Piece**



**Universal Dry Fix Half
Round Ridge End Cap**



**Universal Dry Fix
Angled Ridge End Cap**



**Dry Fix Verge
Eaves Starter Pair**



**End Grain
Batten Bracket**

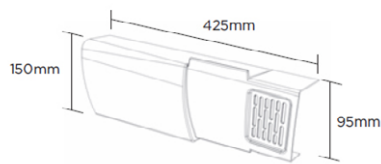


Scan to view the full product page on the Timloc website

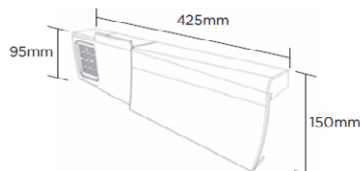
Handed Dry Fix Verge System for Profiled Roof Tiles

A robust, attractive and weather resistant verge system alternative to wet mortar bedding

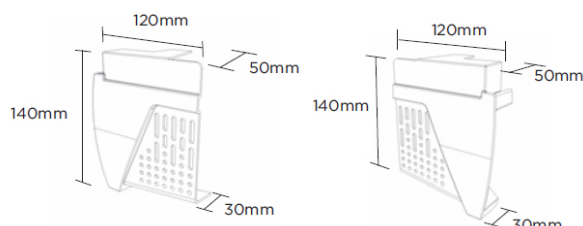
Product Dimensions



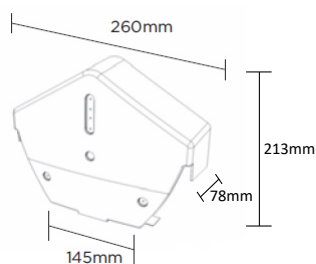
Dry fix verge right hand piece



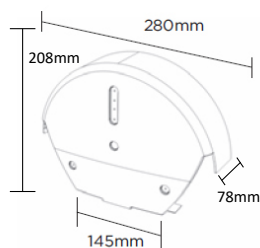
Dry fix verge left hand piece



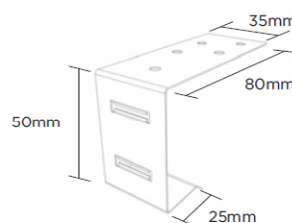
Dry fix verge eaves starter pack (right and left units)



Universal dry fix angled ridge end cap

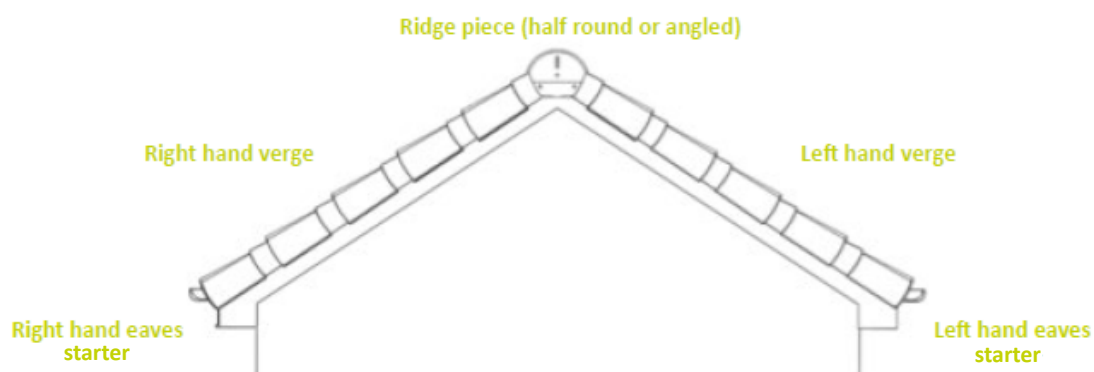


Universal dry fix half round ridge end cap



Dry fix verge end grain batten bracket

Product Detail



Product Codes

Description	Pack Qty	Grey Product Codes	Brown Product Codes	Black Product Codes	Terracotta Product Codes
Dry fix verge right hand piece	20	99117	99116	99137	99118
Dry fix verge left hand piece	20	99121	99120	99138	99122
Universal dry fix angled ridge end cap	10	99109	99108	99107	99110
Universal dry fix half round ridge end cap	10	99113	99112	99136	99114
Dry fix verge eaves starter pack (left & right hand units)	1 + 1	99126	99125	99130	99127
Dry fix verge end grain batten bracket (optional)	20	99124	99124	99124	99124

Interlocking Plain Tile Dry Verge

A robust, attractive and weather resistant verge system alternative to wet mortar bedding for Interlocking Plain tiles

Use

- Developed for Interlocking Plain concrete tiles
- Suitable for most pitched roof types from 15-55°
- Verges with or without bargeboards
- New build and refurbishment projects

Features and Benefits

- Universal installation – LH & RH sides are interchangeable.
- Long lasting, reliable, and virtually maintenance free.
- Protects against wind uplift, water ingress & general deterioration.
- Easy, fast, clean and generally safer mortar free installation.
- Allows virtually all-weather installation.
- Strong but supple for easy flexing and sliding along the tiles.
- Secure fit around the tile reassurance.
- Maintains consistently smart appearance.
- Not impacted by building settlement.
- Meets mechanical fix legislation requirements.
- The system also offers a unique steel fixing bracket option that presents flexible fixing points for use with alternative size counter battens or straight onto tile batten ends. The bracket avoids the reliance of end grain fixing, which can cause splitting and consequential damp penetration issues.

Quality

- Helping to meet BS 5534 Code of practice for slating and tiling
- Complies with all other relevant regulations and standards
- Manufactured to BS EN ISO 9001 and BS EN ISO 14001
- Independently tested and complies with BS8612

Material and Colour Choice

- UV protected and colour fast polypropylene
- Galvanised steel batten end bracket (optional)
- Available in grey, terracotta, brown, red and black

Installation Advice

Please refer to timloc.co.uk for full recommended installation guidance.

Products in the System

- Interlocking Plain Tile Verge
- Interlocking Plain Tile Verge starter
- Half round ridge (apex) end cap
- Angled ridge (apex) end cap
- End grain batten bracket (optional)

How to Order

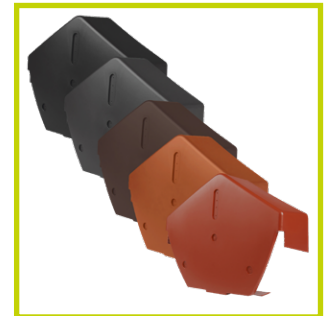
- Select the relevant verge system colour for the project.
- 1 verge piece is required for each roof tile in the sloping run.
- Select the ridge shape for the apex of the system – angled or round.
- Eaves starter must be installed at the beginning of each sloping run.
- 1 optional end grain batten bracket is required for each verge piece installed in the sloping run.



Interlocking Plain Tile Dry Verge Piece (Universal)



Universal Dry Fix Half Round Ridge End Cap



Universal Dry Fix Angled Ridge End Cap



Interlocking Plain Eaves Starter



End Grain Batten Bracket

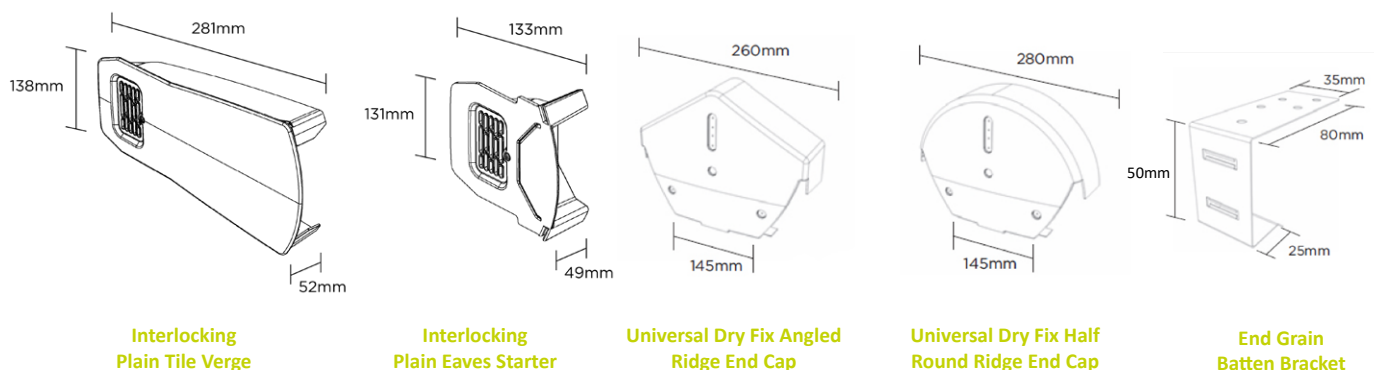


Scan to view the full product page on the Timloc website

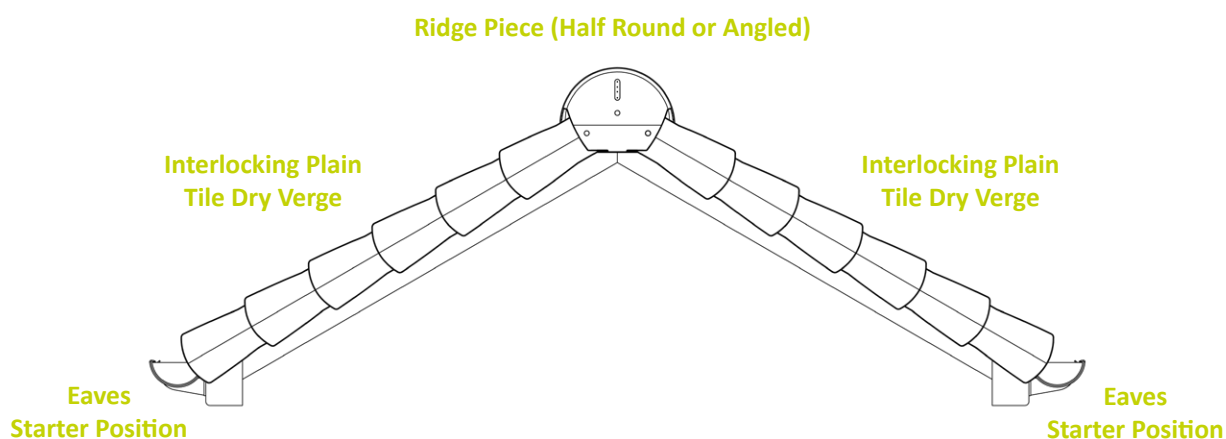
Interlocking Plain Tile Dry Verge

A robust, attractive and weather resistant verge system alternative to wet mortar bedding for Interlocking Plain tiles

Product Dimensions



Product Detail



Product Codes

Description	Pack Qty	Black Product Codes	Grey Product Codes	Terracotta Product Codes	Brown Product Codes	Red Product Codes
Interlocking Plain Tile Dry Fix Verge	40	99173	99174	99175	99176	99182
Interlocking Plain Tile Verge Starter	10	99177	99178	99179	99180	99181
Universal Dry Fix Angled Ridge End Cap	10	99107	99109	99110	99108	99183
Universal Dry Fix Half Round Ridge End Cap	10	99136	99113	99114	99112	99184
Dry Verge Profiled Tile End Grain Batten Bracket (optional)	20	99124	99124	99124	99124	99124

Thin Leading Edge Dry Verge

A robust, attractive and weather resistant verge system alternative to wet mortar bedding for Thin Leading Edge tiles

Use

- Developed for Thin Leading Edge roof tiles
- Suitable for most pitched roof types from 15-55°
- Verges with or without bargeboards
- New build and refurbishment projects

Features and Benefits

- Long lasting, reliable, and virtually maintenance free.
- Protects against wind uplift, water ingress & general deterioration.
- Easy, fast, clean and generally safer mortar free installation.
- Allows virtually all-weather installation.
- Strong but supple for easy flexing and sliding along the tiles.
- Secure fit around the tile reassurance.
- Maintains consistently smart appearance.
- Not impacted by building settlement.
- Meets mechanical fix legislation requirements.
- The system also offers a unique steel fixing bracket option that presents flexible fixing points for use with alternative size counter battens or straight onto tile batten ends. The bracket avoids the reliance of end grain fixing, which can cause splitting and consequential damp penetration issues.

Quality

- Helping to meet BS 5534 Code of practice for slating and tiling
- Complies with all other relevant regulations and standards
- Manufactured to BS EN ISO 9001 and BS EN ISO 14001
- Independently tested and complies with BS8612

Material and Colour Choice

- UV protected and colour fast polypropylene
- Galvanised steel batten end bracket (optional)
- Available in grey, terracotta, brown and black

Installation Advice

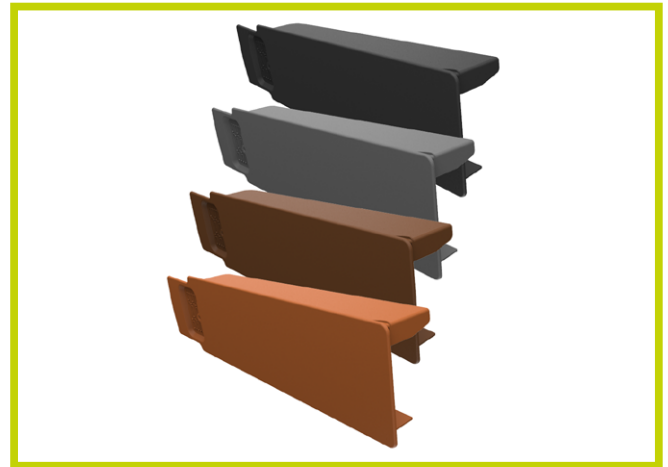
Please refer to timloc.co.uk for full recommended installation guidance

Products in the System

- Thin Leading Edge Verge (LH)
- Thin Leading Edge Verge (RH)
- Thin Leading Edge Eaves Starter (LH)
- Thin Leading Edge Eaves Starter (RH)
- Half Round Ridge (apex) End Cap
- Angled Ridge (apex) End Cap
- End Grain Batten Bracket (optional)

How to Order

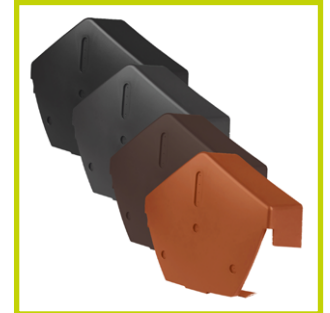
- Select the relevant verge system colour for the project.
- 1 verge piece is required for each roof tile in the sloping run.
- Select the ridge shape for the apex of the system – angled or round.
- Eaves starter must be installed at the beginning of each sloping run.
- 1 optional end grain batten bracket is required for each verge piece installed in the sloping run.



Thin Leading Edge Tile Dry Verge Piece (LH)



Universal Dry Fix Half Round Ridge End Cap



Universal Dry Fix Angled Ridge End Cap



Thin Leading Edge Eaves Starter (LH)



Thin Leading Edge Eaves Starter (RH)



End Grain Batten Bracket

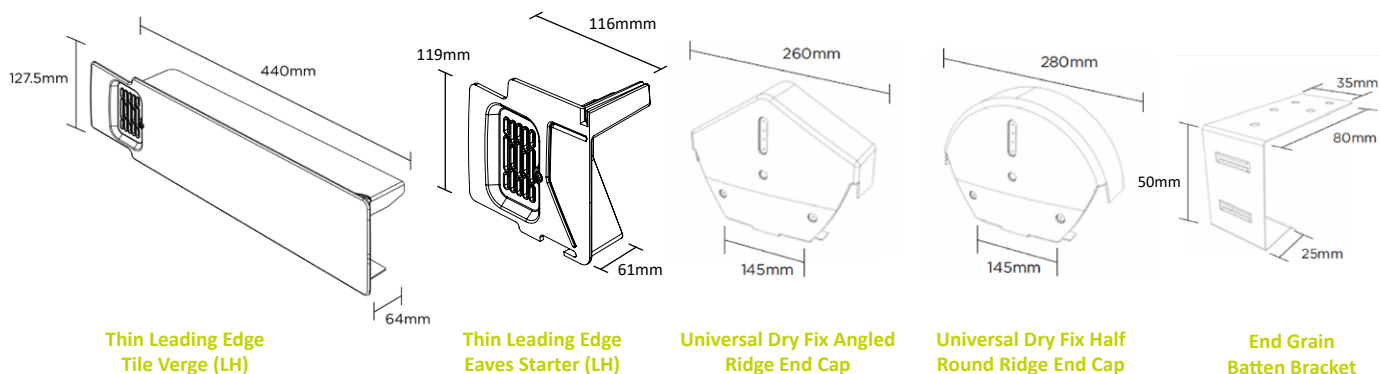


Scan to view the full product page on the Timloc website

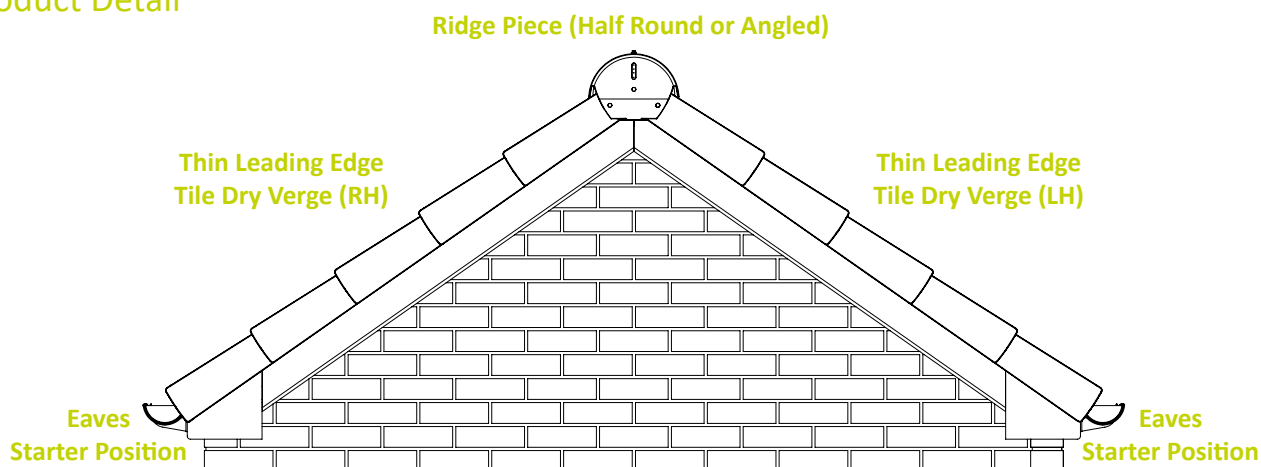
Thin Leading Edge Dry Verge

A robust, attractive and weather resistant verge system alternative to wet mortar bedding for Thin Leading Edge tiles

Product Dimensions



Product Detail



Product Codes

Description	Pack Qty	Black Product Codes	Grey Product Codes	Terracotta Product Codes	Brown Product Codes
Thin Leading Edge Verge (LH)	20	99157	99158	99159	99160
Thin Leading Edge Verge (RH)	20	99161	99162	99163	99164
Thin Leading Edge Verge Starter (LH)	10	99165	99166	99167	99168
Thin Leading Edge Verge Starter (RH)	10	99169	99170	99171	99172
Universal Dry Fix Angled Ridge End Cap	10	99107	99109	99110	99108
Universal Dry Fix Half Round Ridge End Cap	10	99136	99113	99114	99112
Dry Verge Profiled Tile End Grain Batten Bracket (optional)	20	99124	99124	99124	99124

Dry Fix Continuous Verge System for Slate and Thin Slate-Effect Roof Tiles

A continuous verge system for a clean flush finish and an effective and virtually maintenance-free alternative to wet mortar bedding

Use

- Slate and tile thickness between 4-13mm slate and slate-effect tiles

Features and Benefits

- Long lasting, reliable and virtually maintenance free
- Protects against wind uplift, water ingress and general deterioration
- Easy, fast, clean and generally safer mortar free installation
- Allows virtually all weather installation
- Integral internal channel collects and discharges rainwater to the gutter
- Dedicated profiles for the new build and refurbishment applications to ensure secure fitting
- Refurbishment profile design avoids lifting slates and battens
- Concealed eaves closer cap allows for guttering if required
- Secure easy push fit joint unions
- Tough yet flexible allows easy manipulation and secure positioning
- Maintains consistently smart appearance
- Not impacted by building settlement
- Helps prevent entry of large insects, birds and vermin into the roofline
- Meets mechanical fix legislation requirements

Quality

- Helping to meet BS 5534 Code of practice for slating and tiling
- Complies with all other relevant regulations and standards
- Manufactured to BS EN ISO 9001 and BS EN ISO 14001
- Independently tested and complies with BS8612

Material and Colour Choice

- UV protected and colour fast PVC verge and polypropylene ridge and eaves closer caps
- Supplied in dark grey only

Products in the System

- 3m dry fix continuous verge for new build
- 3m dry fix continuous verge for refurbishment
- Angles ridge (apex) piece
- Eaves closer cap pack (right and left handed units)
- Joint union (connects two verge sections together)

Installation Advice

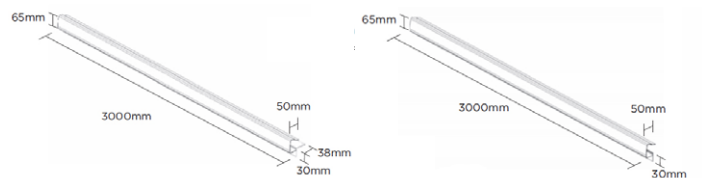
- Please refer to timloc.co.uk for full installation guidance



How to Order

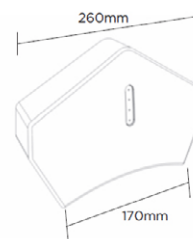
- Measure the length of the roof slope in metres and divide by 3 (product length) to identify how many profiles are required
- Ensure that the correct profile type is ordered for the project - new build or refurbishment
- An eaves closer cap must be installed at the beginning of each sloping run of Dry Fix Continuous Verge
- A Dry Fix Continuous Verge angled ridge piece must be installed at the apex of gable roofs
- A joint union is required when joining two Dry Fix Continuous Verge profiles together

Product Dimensions

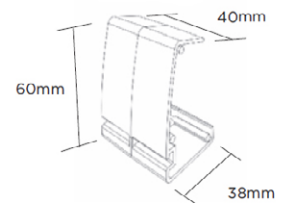


New build dry fix continuous verge

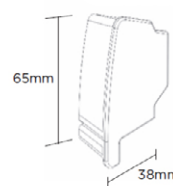
Refurbishment dry fix continuous verge



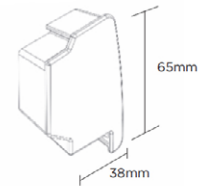
Angled ridge / apex piece



Joint union



Eaves closer cap pack (left unit)



Eaves closer cap pack (right unit)

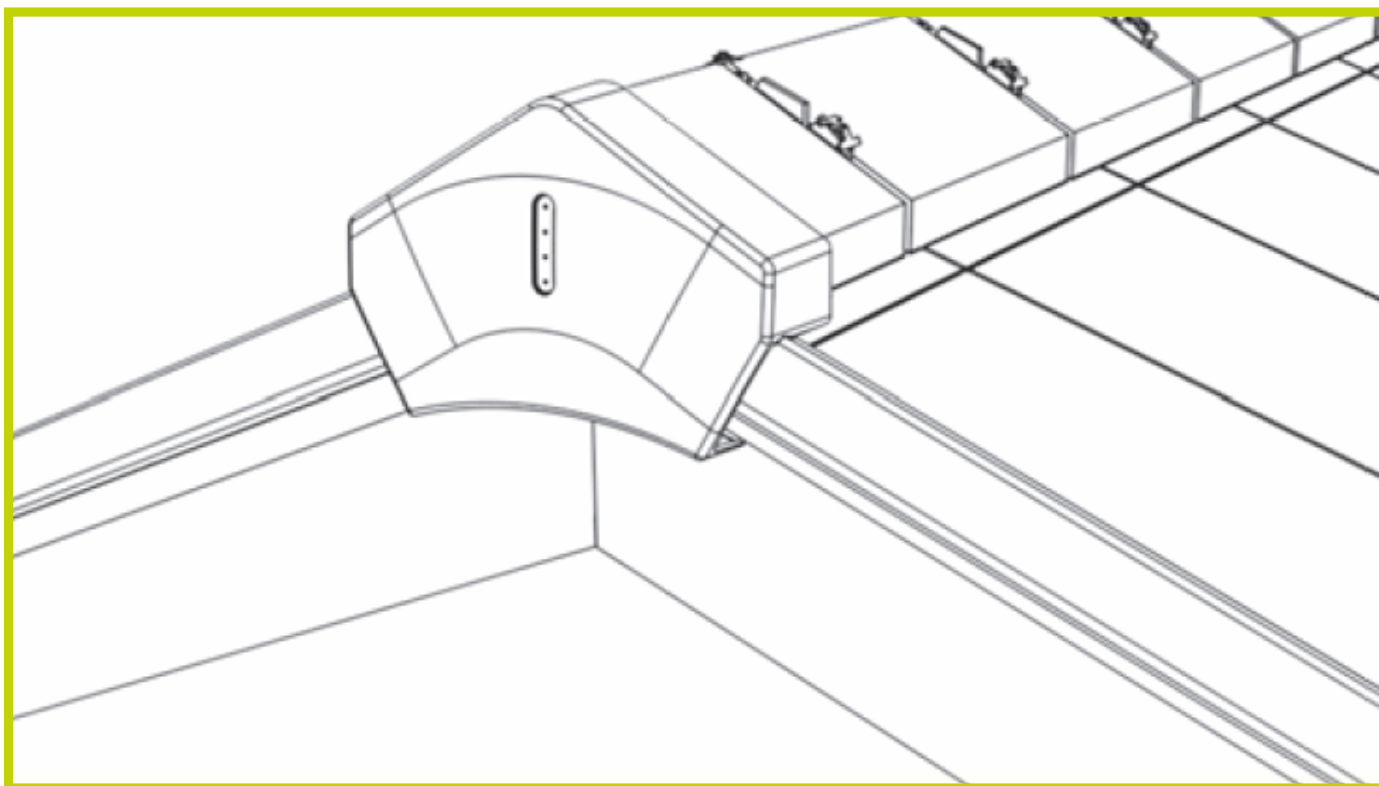


Scan to view the full product page on the Timloc website

Dry Fix Continuous Verge System for Slate and Thin Slate-Effect Roof Tiles

A continuous verge system for a clean flush finish and an effective and virtually maintenance-free alternative to wet mortar bedding.

Product Detail



Product Codes

Description	Pack Qty	Product Codes
3m new build dry fix continuous verge for slate/flat tile	4	66101
3m refurbishment dry fix continuous verge for slate/flat tile	4	66105
Dry fix continuous verge for slate angles ridge/apex piece	1	66120
Dry fix continuous verge for slate/flat tile eaves closer cap pack (left and right units)	1 + 1	66117
Dry fix continuous verge for slate/flat tile joint union	1	66124



Ambi-Soaker | Plain

Ambi-Soaker Universal Dry Fix Abutment Soaker for Plain Tiles

Uses

- Traditional Plain Clay Tiles
- Abutments between a pitched roof and a wall
- New build or refurbishment projects

Features and Benefits

- Pre-formed product shape saves cost and labour time compared to site-fabricated soakers
- Patent Pending design provides a universal product with fixing tabs for both LH or RH Installations
- Fixing tabs can be trimmed away as required
- Sits underneath abutment flashing material. Compatible with stepped or continuous flashings
- Protects roof abutment areas from rain and weather
- Long lasting, reliable and virtually maintenance free
- Lightweight product allows easy handling and installation
- Simple and clean mortar-free installation process
- Helps to minimise contamination of water course compared to lead soakers
- Reduced lead usage within the build helping to deter theft
- Resistant to UV light and acid rain

Quality

- Manufactured to BS EN ISO 9001 and BS EN ISO14001
- Complies with all relevant sections of the Building Regulations
- Satisfies all relevant NHBC requirements

Compatibility

Most Plain tiles from major manufacturers including:

- Redland Rosemary
- Marley Plain
- Russell Traditional Plain
- Sandtoft Humber Plain

Material and Colour Choice

- UV protected and colour-fast Polypropylene
- Available in Black only



Installation Advice

- Please refer to timloc.co.uk for recommended installation guidance.

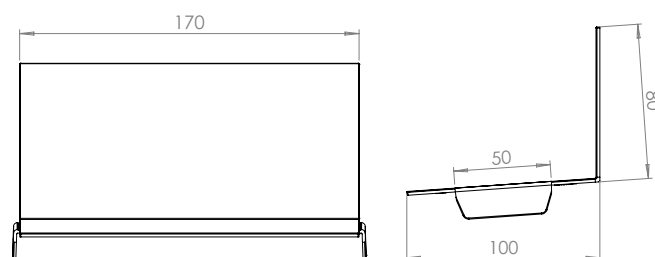
How to Order

- Ambi-Soakers are fitted one unit per tile for the entire length of the abutment. Check the pack quantity against the number of tiles in the run to ensure you have enough Ambi-Soaker units.

Product Codes

Description	Colour	Pack Qty	Product Code
Ambi-Soaker for Plain Tiles	Black	50	AS-PLAIN

Product Dimensions



Scan to view the full product page on the Timloc website



Ambi-Soaker | Interlocking Plain

Ambi-Soaker Universal Dry Fix Abutment Soaker for Interlocking Plain Tiles

Uses

- Interlocking Plain Tiles
- Abutments between a pitched roof and a wall
- New build or refurbishment projects

Features and Benefits

- Pre-formed product shape saves cost and labour time compared to site-fabricated soakers
- Patent Pending design provides a universal product with fixing tabs for both LH or RH Installations
- Fixing tabs can be trimmed away as required
- Sits underneath abutment flashing material. Compatible with stepped or continuous flashings
- Protects roof abutment areas from rain and weather
- Long lasting, reliable and virtually maintenance free
- Lightweight product allows easy handling and installation
- Simple and clean mortar-free installation process
- Helps to minimise contamination of water course compared to lead soakers
- Reduced lead usage within the build helping to deter theft
- Resistant to UV light and acid rain

Quality

- Manufactured to BS EN ISO 9001 and BS EN ISO14001
- Complies with all relevant sections of the Building Regulations
- Satisfies all relevant NHBC requirements

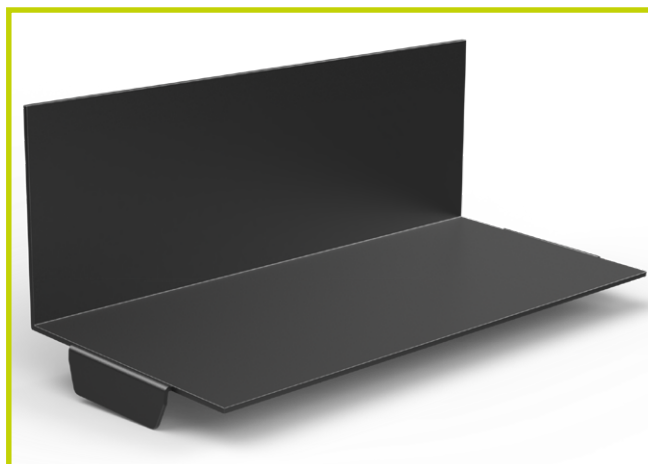
Compatibility

Most Interlocking Plain tiles from major manufacturers including:

- Marley Ashmore
- Redland Duoplain
- Forticrete Gemini

Material and Colour Choice

- UV protected and colour-fast Polypropylene
- Available in Black only



Installation Advice

- Please refer to www.timloc.co.uk for recommended installation guidance.

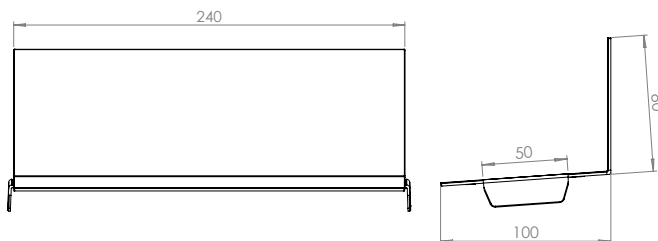
How to Order

- Ambi-Soakers are fitted one unit per tile for the entire length of the abutment. Check the pack quantity against the number of tiles in the run to ensure you have enough Ambi-Soaker units.

Product Codes

Description	Colour	Pack Qty	Product Code
Ambi-Soaker for Interlocking Plain	Black	40	AS-INTPLAIN

Product Dimensions



Scan to view the full product page on the Timloc website



Ambi-Soaker | Slate

Ambi-Soaker Universal Dry Fix Abutment Soaker for Slates

Uses

- Natural or Synthetic slates
- Abutments between a pitched roof and a wall
- New build or refurbishment projects

Features and Benefits

- Pre-formed product shape saves cost and labour time compared to site-fabricated soakers
- Universal product for both LH or RH installations
- Product can be trimmed to length as required for smaller slate sizes
- Sits underneath abutment flashing material. Compatible with stepped or continuous flashings
- Protects roof abutment areas from rain and weather
- Long lasting, reliable and virtually maintenance free
- Lightweight product allows easy handling and installation
- Simple and clean mortar-free installation process
- Helps to minimise contamination of water course compared to lead soakers
- Reduced lead usage within the build helping to deter theft
- Resistant to UV light and acid rain

Quality

- Manufactured to BS EN ISO 9001 and BS EN ISO14001
- Complies with all relevant sections of the Building Regulations
- Satisfies all relevant NHBC requirements

Compatibility

- Natural or Synthetic Slates
- Slates sizes 600mm x 300mm or 500mm x 250mm
- Product can be trimmed to suit smaller slate sizes if required

Material and Colour Choice

- UV protected and colour-fast Polypropylene
- Available in Black only



Installation Advice

- Please refer to timloc.co.uk for recommended installation guidance

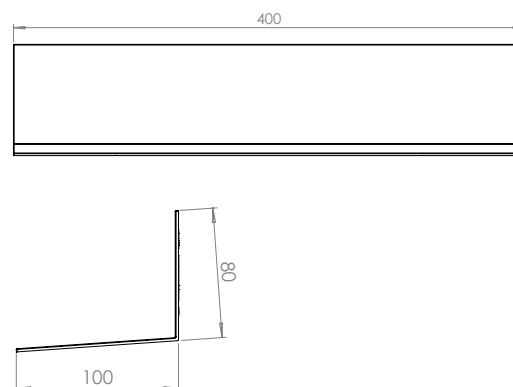
How to Order

- Ambi-Soakers are fitted one unit per slate for the entire length of the abutment. Check the pack quantity against the number of slates in the run to ensure you have enough Ambi-Soaker units.

Product Codes

Description	Colour	Pack Qty	Product Code
Ambi-Soaker for Slates	Black	50	AS-SLATE

Product Dimensions



Scan to view the full product page on the Timloc website



Ambi-Soaker | Thin Leading Edge

Ambi-Soaker Universal Dry Fix Abutment Soaker for Large Format Thin Leading Edge Tiles

Uses

- Thin Leading Edge Tiles
- Abutments between a pitched roof and a wall
- New build or refurbishment projects

Features and Benefits

- Pre-formed product shape saves cost and labour time compared to site-fabricated soakers
- Patent Pending design provides a universal product with fixing tabs for both LH or RH Installations
- Fixing tabs can be trimmed away as required
- Sits underneath abutment flashing material. Compatible with stepped or continuous flashings
- Protects roof abutment areas from rain and weather
- Long lasting, reliable and virtually maintenance free
- Lightweight product allows easy handling and installation
- Simple and clean mortar-free installation process
- Helps to minimise contamination of water course compared to lead soakers
- Reduced lead usage within the build helping to deter theft
- Resistant to UV light and acid rain

Quality

- Manufactured to BS EN ISO 9001 and BS EN ISO14001
- Complies with all relevant sections of the Building Regulations
- Satisfies all relevant NHBC requirements

Compatibility

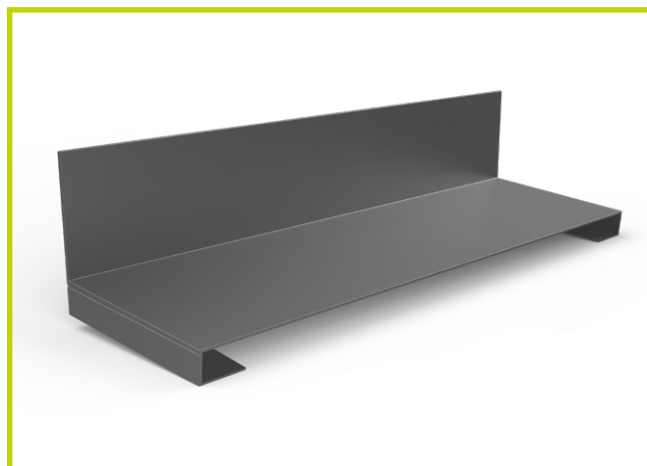
Most Thin Leading Edge large format tiles from major manufacturers including:

- Marley Edgemere
- Redland Richmond
- Sandtoft TLE
- Russell Galloway
- Lagan Elite

*Maximum compatible tile thickness = 17mm

Material and Colour Choice

- UV protected and colour-fast Polypropylene
- Available in Grey only



Installation Advice

- Please refer to timloc.co.uk for recommended installation guidance

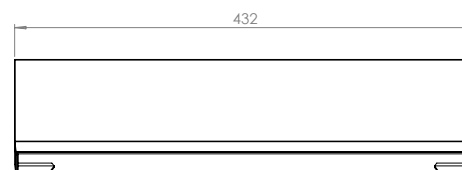
How to Order

- Ambi-Soakers are fitted one unit per tile for the entire length of the abutment. Check the pack quantity against the number of tiles in the run to ensure you have enough Ambi-Soaker units.

Product Codes

Description	Colour	Pack Qty	Product Code
Ambi-Soaker for Thin Leading Edge	Grey	50	AS-TLE

Product Dimensions



Scan to view the full product page on the Timloc website



Ambi-Soaker | Flat

Ambi-Soaker Universal Dry Fix Abutment Soaker for Large Format Flat Tiles

Uses

- Large Format Flat Tiles
- Abutments between a pitched roof and a wall
- New build or refurbishment projects

Features and Benefits

- Pre-formed product shape saves cost and labour time compared to site-fabricated soakers
- Patent Pending design provides a universal product with fixing tabs for both LH or RH Installations
- Fixing tabs can be trimmed away as required
- Sits underneath abutment flashing material. Compatible with stepped or continuous flashings
- Protects roof abutment areas from rain and weather
- Long lasting, reliable and virtually maintenance free
- Lightweight product allows easy handling and installation
- Simple and clean mortar-free installation process
- Helps to minimise contamination of water course compared to lead soakers
- Reduced lead usage within the build helping to deter theft
- Resistant to UV light and acid rain

Quality

- Manufactured to BS EN ISO 9001 and BS EN ISO14001
- Complies with all relevant sections of the Building Regulations
- Satisfies all relevant NHBC requirements

Compatibility

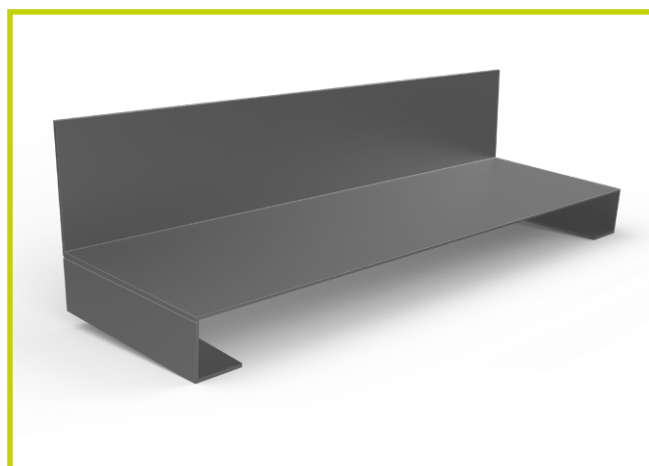
Most Flat large format tiles from major manufacturers including:

- Marley Modern
- Marley Duo Modern
- Redland Mini Stonewold
- Sandtoft Calderdale
- Russell Grampian
- Russell Highland
- Lagan Flat

*Maximum compatible tile thickness = 32mm

Material and Colour Choice

- UV protected and colour-fast Polypropylene
- Available in Grey only



Installation Advice

- Please refer to timloc.co.uk for recommended installation guidance

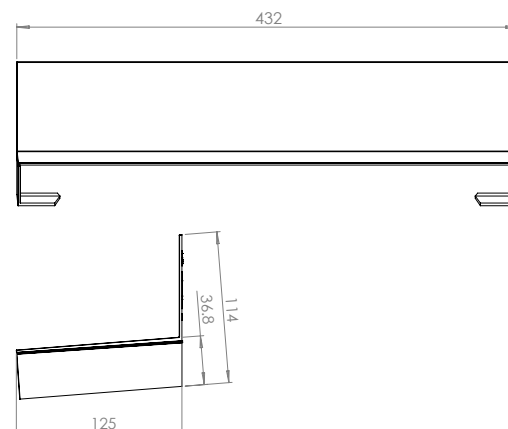
How to Order

- Ambi-Soakers are fitted one unit per slate for the entire length of the abutment. Check the pack quantity against the number of slates in the run to ensure you have enough Ambi-Soaker units.

Product Codes

Description	Colour	Pack Qty	Product Code
Ambi-Soaker for Flat Tiles	Grey	30	AS-FLAT

Product Dimensions



Scan to view the full product page on the Timloc website



LEAD-FREE FLASHING

PbFree Lead-free Flashing

The lead alternative high-performance, low-cost aluminium flashing

Use

- Same applications as traditional lead flashing including flat roof connection, dormers, valley gutters, step and cover flashing, cavity walls and apron flashing
- Can be used in any climate worldwide (-40°C / +90°C)

Features and Benefits

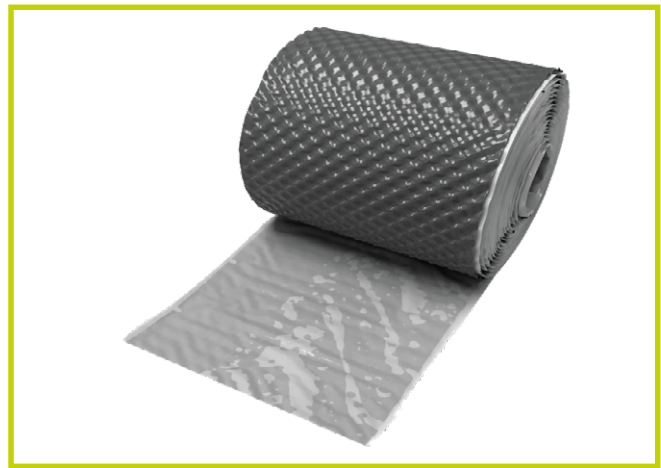
- Versatile and durable
- 5m roll length
- Flexible and lightweight
- Easy to cut and repair
- Unique dimpled profile to provide additional strength

Quality

- Can be used in any climate worldwide (-40°C / +90°C)

Installation Advice

- PbFree is installed and worked in a similar way to traditional lead flashing.
- Minimum working temperature is 5°C.
- Can be applied and worked in any direction using a mallet, roller or by hand.
- Can be cut using scissors or knife.
- Before fixing to any building material surface the protective paper should be left in place until the final shape and position of the flashing is determined.
- If the building material surface is unstable then bituminous primer should be applied.
- Any jointing detail should have a minimum overlap of 100mm.



Composition and Colour Choice

- Aluminium flashing
- Available in Grey only

Product Codes

Description	Width	Quantity	Product Code
PbFree Lead-free Flashing	150mm	1	LF150
PbFree Lead-free Flashing	300mm	1	LF300
PbFree Lead-free Flashing	450mm	1	LF450



Scan to view the full product page on the Timloc website

MEMBREATHE

by **timloc**

115gsm Breathable Membrane

3 layer, premium performance breather membrane

Use

- In a fully supported or unsupported tiled, slated or metal roof system
- Draped unsupported over rafters
- Laid directly over insulation

Features and Benefits

- Available in 1m and 1.5m widths
- Light grey upper surface, branded with MemBreathe by Timloc logo
- 3 layer waterproof membrane
- Lightweight, flexible and easy to use
- Excellent tensile and tear strength
- UV stable (up to 3 months exposure)
- Suitable for warm and cold roof application

Quality

- BBA independent certification
- CE compliant to EN 13859-1
- Tested in line with BS 5534:2014 Annex A (see Zone Suitability table below)

Installation Advice

- Please refer to the Technical Support section of timloc.co.uk for full installation advice

Material

- Made from high tensile spun-bonded polypropylene layers around a microporous polypropylene film
- Grey upper layer with branding
- Grey lower layer

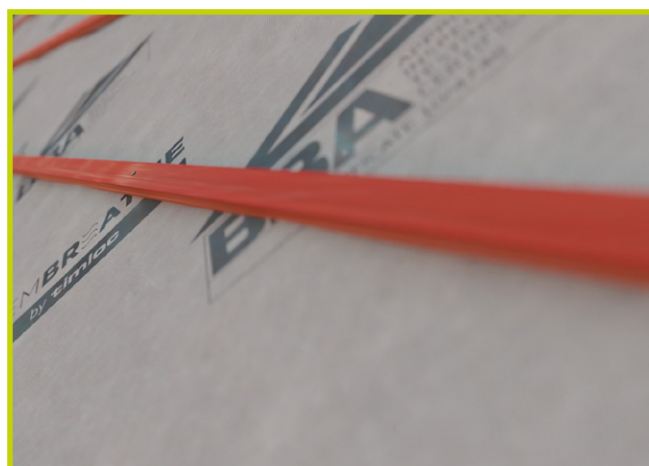
Zone Suitability

- When tested in line with BS 5534:2014 Annex A, MemBreathe by Timloc 115gsm is suitable for the following applications and zones:

345mm Batten Gauge	250mm Batten Gauge	345mm Batten Gauge - Taped Laps	250mm Batten Gauge - Taped Laps
Zones 1-2	All zones	All zones	All zones

Lap Size

Roof Pitch	Min. Horizontal Lap - Partially Supported	Min. Horizontal Lap - Fully Supported	Min. Vertical Lap
12.5-14°	225mm	150mm	100mm
15°+	150mm	100mm	100mm



Technical Data

	1m	1.5m
Roll Weight (kg)	5.8kg	8.7kg
Weight (g/m ²)	115g/m ²	115g/m ²
Roll Length (m)	50m	50m
Roll Width (m)	1.0m	1.5m
Roll Area (m ²)	50m ²	75m ²
Colour	Light grey upper Grey lower	Light grey upper Grey lower
Tensile Strength (EN12311-1)	MD 195N/50mm TD 130N/50mm	MD 195N/50mm TD 130N/50mm
Elongation (EN12311-1)	MD 51% TD 65%	MD 51% TD 65%
Nail Tear (EN12310-1)	MD 99N TD 110N	MD 99N TD 110N
Hydrostatic Head (BS EN 20811)	281cm	281cm
Water Vapour Transmission (Sd) (m)	0.02	0.02
Reaction to Fire (EN 13501-1)	Class E	Class E
Resistance to Streaming Water (MOAT69:4.2.2)	Pass	Pass
Resistance to Water Penetration (EN 13859-1)	Class W1	Class W1
UV Resistance	3 months	3 months

Product Codes

Description	Width	Qty	Product Code
MemBreathe 115gsm Membrane	1.0m	1	MEM11550
MemBreathe 115gsm Membrane	1.5m	1	MEM11575

MEMBREATHE

by **timloc**

135gsm Breathable Membrane

3 layer, premium performance breather membrane

Use

- In a fully supported or unsupported tiled, slated or metal roof system
- Draped unsupported over rafters
- Laid directly over insulation
- Laid directly over sarking boards (Scottish Practice)

Features and Benefits

- Available in 1m and 1.5m widths
- Blue upper surface, branded with MemBreathe by Timloc logo
- 3 layer waterproof membrane
- Lightweight, flexible and easy to use
- Excellent tensile and tear strength
- UV stable (up to 3 months exposure)
- Suitable for warm and cold roof applications

Quality

- BBA independent certification
- CE compliant to EN 13859-1
- Tested in line with BS 5534:2014 Annex A (see Zone Suitability table below)

Installation Advice

- Please refer to the Technical Support section of timloc.co.uk for full installation advice

Material

- Made from high tensile spun-bonded polypropylene layers around a microporous polypropylene film
- Blue upper layer with branding
- White lower layer

Zone Suitability

- When tested in line with BS 5534:2014 Annex A, MemBreathe by Timloc 135gsm is suitable for the following applications and zones:

345mm Batten Gauge	250mm Batten Gauge	345mm Batten Gauge - Taped Laps	250mm Batten Gauge - Taped Laps
Zones 1-3	All zones	All zones	All zones

Lap Size

Roof Pitch	Min. Horizontal Lap - Partially Supported	Min. Horizontal Lap - Fully Supported	Min. Vertical Lap
12.5-14°	225mm	150mm	100mm
15°+	150mm	100mm	100mm



Technical Data

	1m	1.5m
Roll Weight (kg)	6.8kg	10.2kg
Weight (g/m ²)	135g/m ²	135g/m ²
Roll Length (m)	50m	50m
Roll Width (m)	1.0m	1.5m
Roll Area (m ²)	50m ²	75m ²
Colour	Blue upper White lower	Blue upper White lower
Tensile Strength (EN12311-1)	MD 265N/50mm TD 184N/50mm	MD 265N/50mm TD 184N/50mm
Elongation (EN12311-1)	MD 74% TD 97%	MD 74% TD 97%
Nail Tear (EN12310-1)	MD 167N TD 253N	MD 167N TD 253N
Hydrostatic Head (BS EN 20811)	433cm	433cm
Water Vapour Transmission (Sd) (m)	0.02	0.02
Reaction to Fire (EN 13501-1)	Class E	Class E
Resistance to Streaming Water (MOAT69:4.2.2)	Pass	Pass
Resistance to Water Penetration (EN 13859-1)	Class W1	Class W1
UV Resistance	3 months	3 months

Product Codes

Description	Width	Qty	Product Code
MemBreathe 135gsm Membrane	1.0m	1	MEM13550
MemBreathe 135gsm Membrane	1.5m	1	MEM13575

MEMBR_≈ATHE

by **timloc**

165gsm Breathable Membrane

3 layer, premium performance breather membrane

Use

- In a fully supported or unsupported tiled, slated or metal roof system
- Draped unsupported over rafters
- Laid directly over insulation
- Laid directly over sarking boards (Scottish Practice)

Features and Benefits

- Available in 1m and 1.5m widths
- Green upper surface, branded with MemBreathe by Timloc logo
- 3 layer waterproof membrane
- Lightweight, flexible and easy to use
- Excellent tensile and tear strength
- UV stable (up to 3 months exposure)
- Suitable for warm and cold roof applications

Quality

- BBA independent certification
- CE compliant to EN 13859-1
- Tested in line with BS 5534:2014 Annex A (see Zone Suitability table below)

Installation Advice

- Please refer to the Technical Support section of timloc.co.uk for full installation advice

Material

- Made from high tensile spun-bonded polypropylene layers around a microporous polypropylene film
- Green upper layer with branding
- White lower layer

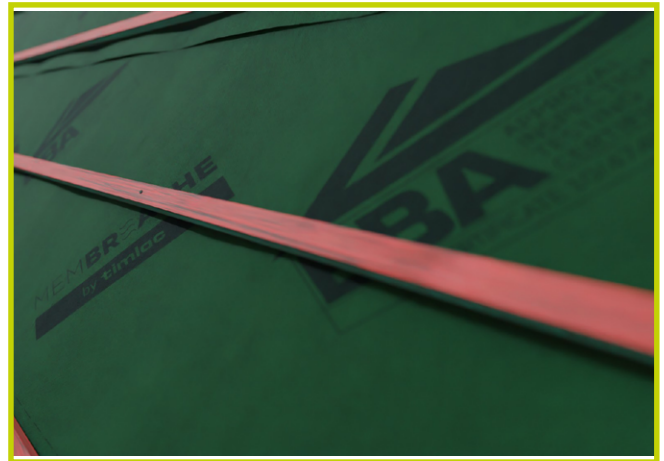
Zone Suitability

- When tested in line with BS 5534:2014 Annex A, MemBreathe by Timloc 165gsm is suitable for the following applications and zones:

345mm Batten Gauge	250mm Batten Gauge	345mm Batten Gauge - Taped Laps	250mm Batten Gauge - Taped Laps
Zones 1-3	All zones	All zones	All zones

Lap Size

Roof Pitch	Min. Horizontal Lap - Partially Supported	Min. Horizontal Lap - Fully Supported	Min. Vertical Lap
12.5-14°	225mm	150mm	100mm
15°+	150mm	100mm	100mm



Technical Data

	1m	1.5m
Roll Weight (kg)	8kg	12kg
Weight (g/m ²)	165g/m ²	165g/m ²
Roll Length (m)	50m	50m
Roll Width (m)	1.0m	1.5m
Roll Area (m ²)	50m ²	75m ²
Colour	Green upper White lower	Green upper White lower
Tensile Strength (EN12311-1)	MD 355N/50mm TD 230N/50mm	MD 355N/50mm TD 230N/50mm
Elongation (EN12311-1)	MD 45% TD 77%	MD 45% TD 77%
Nail Tear (EN12310-1)	MD 188N TD 229N	MD 188N TD 229N
Water Vapour Transmission (Sd) (m)	<0.03	<0.03
Reaction to Fire (EN 13501-1)	Class E	Class E
Resistance to Streaming Water (MOAT69:4.2.2)	Pass	Pass
Resistance to Water Penetration (EN 13859-1)	Class W1	Class W1
UV Resistance	3 months	3 months

Product Codes

Description	Width	Qty	Product Code
MemBreathe 165gsm Membrane	1.0m	1	MEM16550
MemBreathe 165gsm Membrane	1.5m	1	MEM16575

Roofline | Technical Information and Installation Advice

The range of roofline and above products manufactured by Timloc are all designed to fit within the eaves of the roof. They fall into two product groups which Timloc choose to refer to as 'primary' and 'secondary' roof ventilators. Products from these two groups work together to form a range of reliable roof eaves ventilation systems.

Primary roof ventilators fit externally within the eaves, usually within either the soffit board or fascia board, and provide an appropriately sized opening for air to flow into and out of the roof space. They incorporate rows of slots or holes which are large enough to allow the required volume of air to flow freely without danger of blockage by dirt, dust, cobwebs, etc but are small enough to prevent the entry of vermin or large nestbuilding insects such as bees and wasps. All Timloc ventilators have 3.5 - 4mm wide slots or holes in accordance with the recommendations of BS. 5250 : 2011.

Secondary roof ventilators fit higher up within the eaves, usually between the rafters above the wallplate position. They hold down the quilt of roof insulation material and prevent it from restricting the flow of air to and from the primary roof ventilator.

In most cases it is essential that both primary and secondary roof ventilators are used in conjunction with each other in order to provide a reliable ventilation system.

Free Airflow Requirements

The Building Regulations require differing levels of roof ventilation depending on the design of the roof. It is very important to identify the type of roof which is to be constructed and ensure that the correct volume of free airflow is provided by the roof ventilators. Please refer to the four accompanying illustrations which detail the main variations in roof type.

Primary Roof Ventilators

- With a standard pitched roof where the pitch of the roof is 15 degrees or greater and the roof space is an attic or loft a free airflow is required which is equivalent to a continuous 10mm opening (10,000 mm² per metre run). See Fig.1
- With a pitched roof where the pitch of the roof is less than 15 degrees and the roof space is an attic or loft a free airflow is required which is equivalent to a continuous 25mm opening (25,000 mm² per metre run). See Fig. 2
- With a pitched roof where the roof space contains living accommodation and part of the ceiling and insulation follow the same line as the rafters a free airflow is required which is equivalent to a continuous 25mm opening (25,000 mm² per metre run). See Fig. 3
- With a flat roof a free airflow is required which is equivalent to a continuous 25mm opening (25,000 mm² per metre). See Figs. 4a,4b and 4c
- In all cases the ventilators must run continuously along the eaves and along opposite sides of the building so as to create a cross flow ventilation action

Secondary Roof Ventilators

- With a standard pitched roof where the pitch of the roof is 15 degrees or greater and the roof space is an attic or loft a ventilation channel at least 25mm deep must be maintained between the roof insulation and the underside of the roof covering. See Fig.1
- With a pitched roof where the pitch of the roof is less than 15 degrees and the roof space is an attic or loft a ventilation channel at least 25mm deep must be maintained between the roof insulation and the underside of the roof covering. See Fig. 2
- With a pitched roof where the roof space contains living accommodation and part of the ceiling and insulation follow the same line as the rafters a ventilation channel at least 25mm deep must be maintained between the roof insulation and the underside of the roof covering. See Fig. 3
- With a flat roof a ventilation channel at least 50mm deep must be maintained between the roof insulation and the underside of the roof deck. See Fig. 4
- In all cases the ventilation channel must run continuously along the eaves and along opposite sides of the building so as to create a cross flow ventilation action

Vapour Permeable Underlay

All vapour permeable underlays require a full convection tight ceiling, if condensation problems within the loft space are to be avoided. Timloc's judgement is that this 100% sealing of all apertures including pipes, wiring and fittings, in addition to its basic structure is not achievable in practice, and consequently there will be a risk of condensation occurring

Timloc recommend exploring the practicality and feasibility of achieving a full convection tight ceiling i.e. to all apertures (pipes, wiring and light fittings)

Fig. 1
Standard pitched roof
15° or above

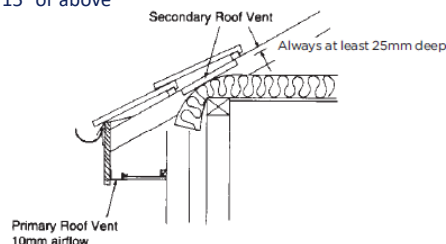


Fig. 2
Shallow pitched roof
Below 15°

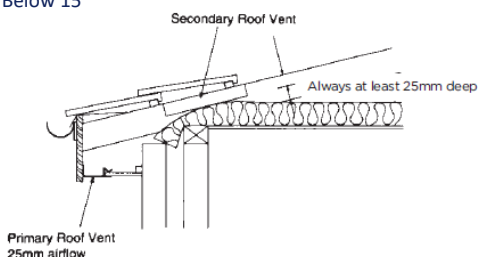


Fig. 3
Warm pitch roof

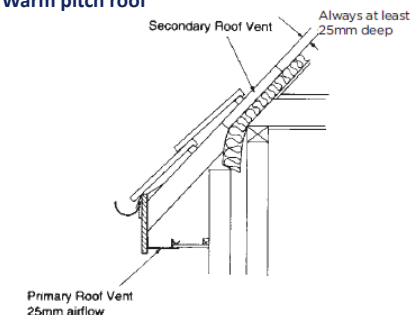


Fig. 4a
Flat roof

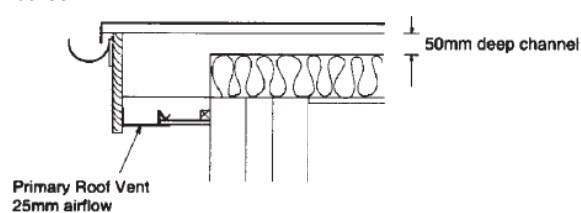


Fig. 4b
Flat roof

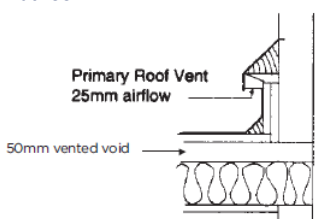
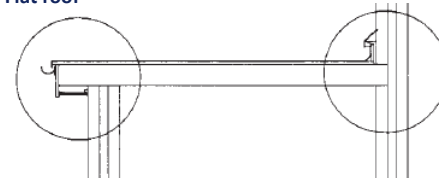


Fig. 4c
Flat roof



Roofline | Technical Information and Installation Advice

Product Selection

Once the required level of free airflow necessary to suit the roof design has been established the choice of ventilation components is dictated by the eaves design, method of construction or the preference of the specifier or end user. Timloc recommend that customers take advantage of the technical advisory service which is freely available to all users and specifiers of Timloc products. The Technical Services Department will be pleased to advise on the most suitable products to suit the application and will prepare a fully itemised schedule of quantities if required. Please provide as much information as possible regarding the roof design and eaves construction detail including a dimensioned drawing if available.

Corbel ventilator

The corbel ventilator is designed to be fitted at the same time that the corbelled brickwork is completed. The fixing clips have protruding tabs which are built in to the perp. mortar joints on the top row of brickwork. If the ventilator is not fitted at this time the fixing clips cannot be used as intended and it will be necessary to drill and plug the brickwork or fit a timber batten on which to fix the ventilator.

The corbel ventilator is only available in the standard 10mm continuous opening version. If ventilation is required which is equivalent to a continuous 25mm opening then an alternative product must be used, a 25mm airflow over fascia ventilator is recommended. It will be necessary to fit this by drilling and plugging the brickwork or fitting a timber batten on which to fix the ventilator.

It is strongly recommended that a plywood felt support is fitted directly above the corbel ventilator in order to prevent sagging roofing felt from restricting airflow through the ventilator. This should project at least 15mm beyond the front of the ventilator.

Push in soffit ventilators

The push in soffit ventilators are fitted into 70mm diameter circular holes cut into the soffit board with a hole saw. These holes should be drilled at 200mm centres in order to provide airflow equivalent to a continuous 10mm opening. The push in ventilators are not suited in situations where an airflow equivalent to a continuous 25mm opening is required. It is very important that the holes are cut accurately and are not oversized otherwise the ventilators will not grip firmly in the fixing holes.

Installation Advice

Due to the wide range of products in the roofline and above range the installation methods are equally varied. It is recommended that the specific installation instructions supplied with the goods are closely followed at the time of installation. Anything which is unclear should be checked with Timloc Technical department.

General advice relevant to key products in the range are detailed below:

Soffit vent type C

The mouth along the edge of the soffit ventilator is ideally suited to accommodate a 6mm thick soffit board. Soffit boards of up to 9mm thick can be accommodated with care but it may sometimes be necessary to chamfer the edge of the board slightly to make insertion easier. Soffit boards over 9mm in thickness cannot be accommodated unless the edge of the board is rebated down to a thickness of 6 - 9mm.

Over fascia ventilators (all types)

Over fascia ventilators fit on the upper edge of the fascia board. It is important to note the height of the over fascia ventilator to be used and make allowance for this when fitting the fascia board. If the height of the ventilator is not taken into account and the fascia board lowered accordingly the tiles may be caused to 'kick up' at the eaves.

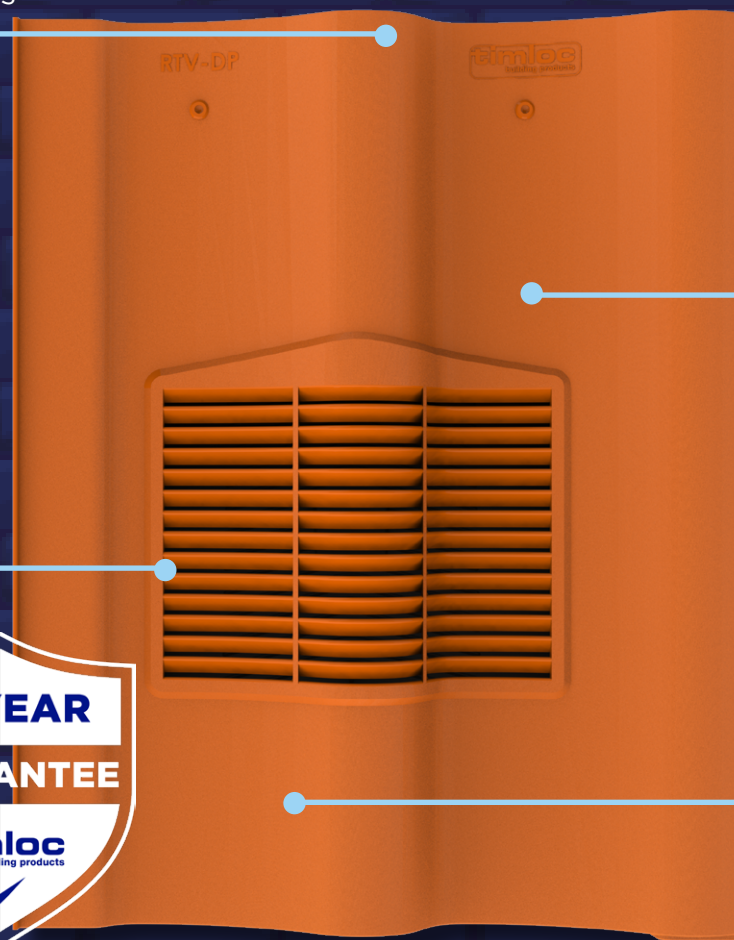
Over fascia ventilators - Products 3011 and 3011-25 only

It is strongly recommended that a plywood felt support is fitted directly above the over fascia ventilator in order to prevent sagging roofing felt from restricting airflow through the ventilator. This should project at least 10mm beyond the front of the ventilator.

INVENTIVE

Roof ventilation solutions

Available in **single**, **pack**,
and **pallet** quantities



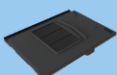

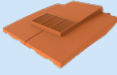
Next day delivery
on the entire
product range

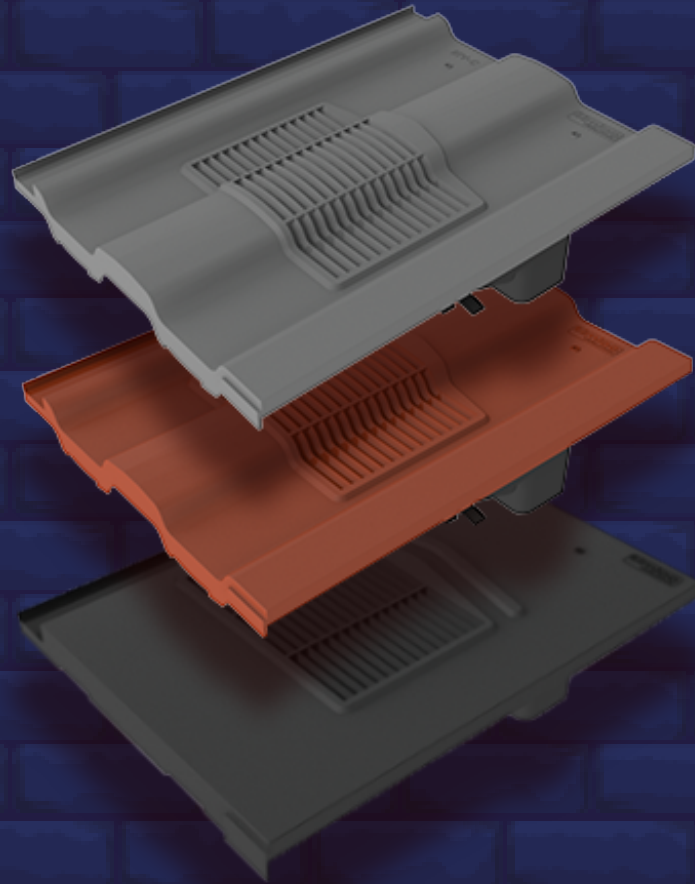
Designed to
suit **popular tile**
and **slate types**

Full range of
adapters and
accessories available

Comprehensive range of **tile and slate vents** from

timloc
building products

Vent	Image	Compatibility	Min. Pitch°	Free Vent Area	Colours	Accessories	Code
Castellated		Lagan Square Top Marley Ludlow Major Redland Renown Russell Cheviot Sandtoft Lindum	20°	10,000mm ²	● ● ● ●	RTV-ADS RTV-ADMULTI RTV-KIT1	RTV-C
Double Pantile		Marley Mendip Quinn Locherne Redland Grovebury Redland Landmark Russell Pennine	20°	10,000mm ²	● ● ● ●	RTV-ADS RTV-ADMULTI RTV-KIT1	RTV-DP
Double Roman		Lagan Double Roll Marley Double Roman Redland 50 Double Roman Russell Double Roman Sandtoft Double Roman	20°	10,000mm ²	● ● ● ●	RTV-ADS RTV-ADMULTI RTV-KIT1	RTV-DR
Flat Edge		Sandtoft Calderdale Edge	20°	10,000mm ²	● ● ● ● ●	RTV-ADS RTV-ADMULTI RTV-KIT1	RTV-FE
Non-Profile		Lagan Flat Marley Duo Modern Marley Modern Redland Mini Stonewold Russell Grampian Russell Highland Sandtoft Calderdale	20°	10,000mm ²	● ● ● ● ●	RTV-ADS RTV-ADMULTI RTV-KIT1	RTV-NP
Thin Leading Edge		Lagan Elite Marley Edgemere Redland Richmond Russell Galloway Sandtoft TLE FP McCann Thin Flat Tile FP McCann Duo Thin Flat Tile	20°	10,000mm ²	● ● ● ● ●	RTV-ADS RTV-ADMULTI RTV-KIT1	RTV-TE
Mini Castellated		Forticrete V2 Marley Ludlow Plus Redland 49 Sandtoft Standard Pattern	17.5°	5,000mm ²	● ● ● ●	RTV-ADMULTI RTV-KIT1	RTV-MC
Single Pantile		Marley Anglia Redland Fenland Pantile Sandtoft Shire	20°	5,000mm ²	● ● ● ●	RTV-ADMULTI RTV-KIT1	RTV-SP
Interlocking Plain		Forticrete Gemini Marley Ashmore Redland Duoplain	22.5°	6,000mm ²	● ● ● ●	RTV-ADP RTV-ADMULTI RTV-KIT1	RTV-IP
Plain		Redland Rosemary Marley Plain Russell Traditional Plain Sandtoft Humber Plain	35°	7,000mm ²	● ● ● ●	RTV-ADP RTV-ADMULTI RTV-KIT1	RTV-P
Low Profile Plain		Redland Rosemary Marley Plain Russell Traditional Plain Sandtoft Humber Plain	35°	6,100mm ²	● ● ● ●	RTV-ADP RTV-ADMULTI RTV-KIT1	RTV-LPP
Slip Plain		Redland Rosemary Marley Plain Russell Traditional Plain Sandtoft Humber Plain	35°	6,100mm ²	● ● ● ●	RTV-ADP RTV-ADMULTI RTV-KIT1	RTV-SLIP
Universal		Customisable fit to a wide range of profiled and plain tiles using alternative flashing sheet	12.5°	20,000mm ² (170mm Ø) 16,000mm ² (150mm Ø) 11,000mm ² (125mm Ø) 8,400mm ² (110mm Ø)	● ● ● ● ●	RTV-KIT1	RTV-UNI
Universal Inline Slate		600 x 300mm slates 500 x 250mm slates	22.5°	9,450mm ²	●	RTV-ADIS RTV-ADMULTI RTV-KIT1	RTV-IS
Small Inline Slate		Small slates 300 x 200mm to 400 x 250mm	22.5°	9,450mm ²	●	RTV-ADIS RTV-ADMULTI RTV-KIT1	RTV-SIS
Hooded Slate		600 x 300mm slates 500 x 250mm slates	22.5°	22,000mm ²	●	RTV-ADHS RTV-ADMULTI RTV-KIT1	RTV-HS
Universal Hooded Slate		600 x 300mm slates 500 x 250mm slates	22.5°	10,000mm ²	●	4101 Pipe Adapter Kit	4001



INVENTIVE

ROOF TILE & SLATE VENTS

Product	Page No.
Castellated Tile Vent	126
Double Pantile Tile Vent	127
Double Roman Tile Vent	128
Flat Edge Tile Vent	129
Non Profile Tile Vent	130
Thin Leading Edge Tile Vent	131
Interlocking Plain Tile Vent	132
Plain Tile Vent	133
Low Profile Plain Tile Vent	134
Slip Plain Tile Vent	135
Single Pantile Tile Vent	136
Mini Castellated Tile Vent	137
Universal Tile Vent	138
Universal Tile Vent 22,000mm ²	139
Inline Slate Vent	140
Small Inline Slate Vent	141
Hooded Slate Vent	142
Universal Hooded Slate Vent	143
Adapters and Accessories	144

INVENTIVE

Roof ventilation solutions

RTV-C | Castellated Tile Vent

Profiled roof tile vent to enable ventilation directly into a roof space or connect to a ducted ventilation system

Uses

- On roofs with Castellated profile roof tiles
- Enables ventilation directly into a roof space
- Can also be connected to a ducted ventilation system inside the building

Features and Benefits

- Suitable for roofs with a minimum pitch of 20°
- Free ventilation area of 10,000mm²
- Sized to replace one Castellated tile to provide a continuous visual appearance along the roof when viewed at all levels
- Shaped to manage and channel rainwater back down onto the roof tiles and away from the vent opening
- 4mm spaced external grille to prevent rainwater ingress and keep out large insects, vermin and debris
- Integrated clips to ensure a secure fit to surrounding roof tiles
- UV stabilised top for continuous exposure to sunlight
- Lightweight and easy to handle

Relevant Standards

- BS EN 490:2011 Concrete roofing tiles and fittings for roof covering and wall cladding - product specifications (+A1:2017)
- BS 5250: 2021 Management of moisture in buildings - Code of practice
- BS 5534:2014 Slating and tiling for pitched roofs and vertical cladding - code of practice (+A2:2018)
- Manufactured to BS EN ISO 9001:2015 and BS EN ISO 14001:2015
- Complies with all relevant sections of the Building Regulations 2010
- Satisfies all relevant NHBC requirements

Compatibility

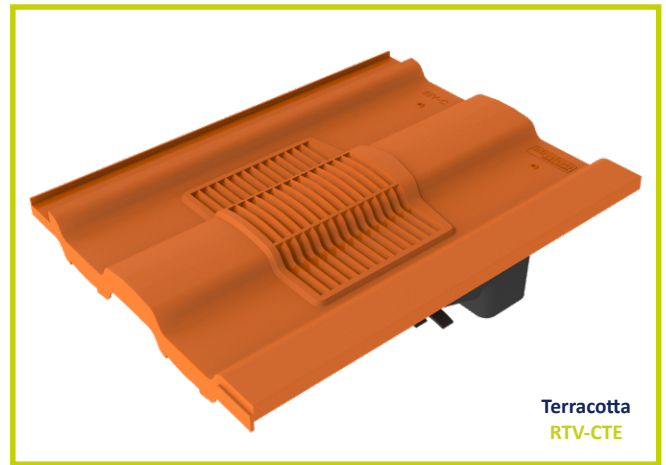
Castellated large format tiles from all major manufacturers including:

- Marley Ludlow Major
- Redland Renown
- Sandtoft Lindum
- Russel Cheviot
- Lagan Square Top

Material and Colour Choice

- Available in Terracotta, Brown, Grey and Red
- Top - UV stabilised coloured injection moulded Polypropylene with textured finish
- Base - Black injection moulded Polypropylene

Scan to view the full product page on the Timloc website



Terracotta
RTV-CTE



Terracotta
RTV-CTE



Brown
RTV-CBR

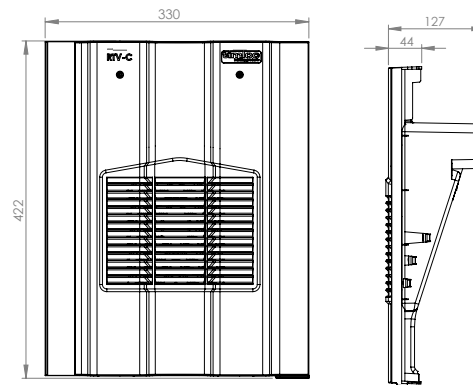


Grey
RTV-CGR



Red
RTV-CRD

Product Dimensions



Compatible Accessories

- Full datasheets available for all accessories

Description	Product Code	Product Image
110mm Flexi-Pipe to aid connection to ventilation duct or soil vent pipe	RTV-KIT1	
Standard adapter to attach the roof tile vent to 110mm ductwork	RTV-ADS	
Multi adapter (RTV-ADMULTI) to aid connection to 100/110/125/150mm duct sizes	RTV-ADMULTI	
RTV-KIT1 and RTV-ADS available as one kit	RTV-KIT2	

Airflow Test Data

RTV-C (100mm duct)	
Flow Rate l/s	Static pressure difference Pa
10	2
20	8
30	17
40	30

Product Codes

Product Description	Colour	Weight	Box Quantity	Product Code	Pack Quantity	Pack Code	Pallet Quantity
Castellated Roof Tile Vent	Terracotta	0.87kg	1	RTV-CTE	8	RTVMULTI-CTE	136
Castellated Roof Tile Vent	Brown	0.87kg	1	RTV-CBR	8	RTVMULTI-CBR	136
Castellated Roof Tile Vent	Grey	0.87kg	1	RTV-CGR	8	RTVMULTI-CGR	136
Castellated Roof Tile Vent	Red	0.87kg	1	RTV-CRD	8	RTVMULTI-CRD	136

NB. RTV-C available in single, pack or pallet quantities. For pack quantities, 8 tile vent assemblies are packaged in one large box.

Roof ventilation solutions

RTV-DP | Double Pantile Tile Vent

Profiled roof tile vent to enable ventilation directly into a roof space or connect to a ducted ventilation system

Uses

- On roofs with Double Pantile profile roof tiles
- Enables ventilation directly into a roof space
- Can also be connected to a ducted ventilation system inside the building

Features and Benefits

- Suitable for roofs with a minimum pitch of 20°
- Free ventilation area of 10,000mm²
- Sized to replace one Double Pantile tile to provide a continuous visual appearance along the roof when viewed at all levels
- Shaped to manage and channel rainwater back down onto the roof tiles and away from the vent opening
- 4mm spaced external grille to prevent rainwater ingress and keep out large insects, vermin and debris
- Integrated clips to ensure a secure fit to surrounding roof tiles
- UV stabilised top for continuous exposure to sunlight
- Lightweight and easy to handle

Relevant Standards

- BS EN 490:2011 Concrete roofing tiles and fittings for roof covering and wall cladding - product specifications (+A1:2017)
- BS 5250: 2021 Management of moisture in buildings – Code of practice
- BS 5534:2014 Slating and tiling for pitched roofs and vertical cladding – code of practice (+A2:2018)
- Manufactured to BS EN ISO 9001:2015 and BS EN ISO 14001:2015
- Complies with all relevant sections of the Building Regulations 2010
- Satisfies all relevant NHBC requirements

Compatibility

Double Pantile large format tiles from all major manufacturers including:

- Marley Mendip
- Redland Grovebury
- Redland Landmark
- Russell Pennine
- Quinn Locherne
- Sandtoft Double Pantile

Material and Colour Choice

- Available in Terracotta, Brown, Grey and Red
- Top - UV stabilised coloured injection moulded Polypropylene with textured finish
- Base – Black injection moulded Polypropylene

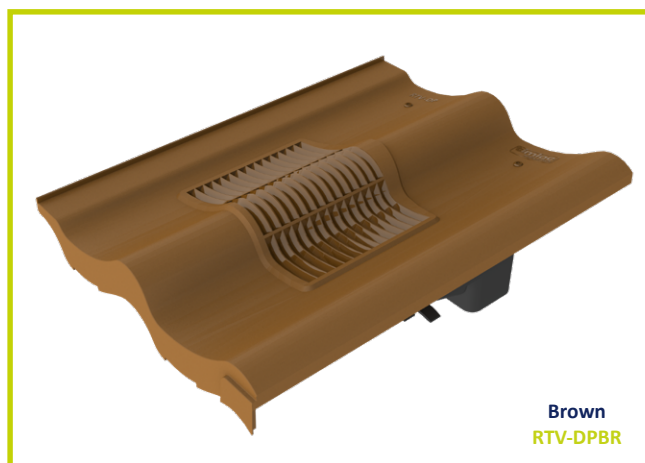
Scan to view the full product page on the Timloc website



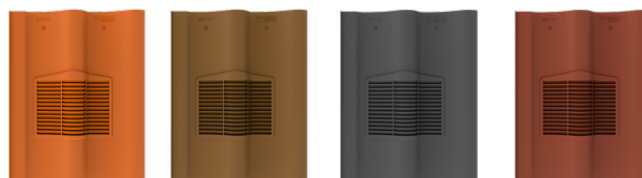
Product Codes

Product Description	Colour	Weight	Box Quantity	Product Code	Pack Quantity	Pack Code	Pallet Quantity
Double Pantile Roof Tile Vent	Terracotta	0.88kg	1	RTV-DPTE	6	RTVMULTI-DPTE	102
Double Pantile Roof Tile Vent	Brown	0.88kg	1	RTV-DPBR	6	RTVMULTI-DPBR	102
Double Pantile Roof Tile Vent	Grey	0.88kg	1	RTV-DPGR	6	RTVMULTI-DPGR	102
Double Pantile Roof Tile Vent	Red	0.88kg	1	RTV-DPRD	6	RTVMULTI-DPRD	102

NB. RTV-DP available in single, pack or pallet quantities. For pack quantities, 6 tile vent assemblies are packaged in one large box.



Brown
RTV-DPBR



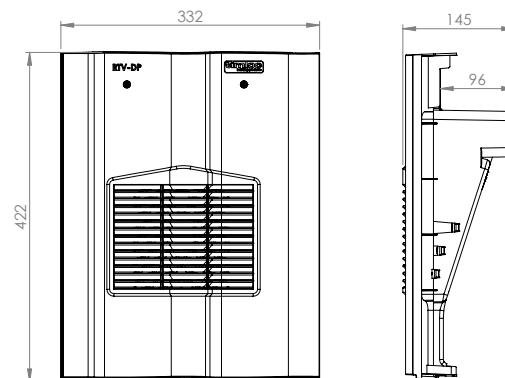
Terracotta
RTV-DPTE

Brown
RTV-DPBR

Grey
RTV-DPGR

Red
RTV-DPRD

Product Dimensions



Compatible Accessories

- Full datasheets available for all accessories

Description	Product Code	Product Image
110mm Flexi-Pipe to aid connection to ventilation duct or soil vent pipe	RTV-KIT1	
Standard adapter to attach the roof tile vent to 110mm ductwork	RTV-ADS	
Multi adapter (RTV-ADMULTI) to aid connection to 100/110/125/150mm duct sizes	RTV-ADMULTI	
RTV-KIT1 and RTV-ADS available as one kit	RTV-KIT2	

Airflow Test Data

RTV-DP (100mm duct)	
Flow Rate l/s	Static pressure difference Pa
10	2
20	8
30	17
40	30

INVENTIVE

Roof ventilation solutions

RTV-DR | Double Roman Tile Vent

Profiled roof tile vent to enable ventilation directly into a roof space or connect to a ducted ventilation system

Uses

- On roofs with Double Roman profile roof tiles
- Enables ventilation directly into a roof space
- Can also be connected to a ducted ventilation system inside the building

Features and Benefits

- Suitable for roofs with a minimum pitch of 20°
- Free ventilation area of 10,000mm²
- Sized to replace one Double Roman tile to provide a continuous visual appearance along the roof when viewed at all levels
- Shaped to manage and channel rainwater back down onto the roof tiles and away from the vent opening
- 4mm spaced external grille to prevent rainwater ingress and keep out large insects, vermin and debris
- Integrated clips to ensure a secure fit to surrounding roof tiles
- UV stabilised top for continuous exposure to sunlight
- Lightweight and easy to handle

Relevant Standards

- BS EN 490:2011 Concrete roofing tiles and fittings for roof covering and wall cladding - product specifications (+A1:2017)
- BS 5250: 2021 Management of moisture in buildings – Code of practice
- BS 5534:2014 Slating and tiling for pitched roofs and vertical cladding – code of practice (+A2:2018)
- Manufactured to BS EN ISO 9001:2015 and BS EN ISO 14001:2015
- Complies with all relevant sections of the Building Regulations 2010
- Satisfies all relevant NHBC requirements

Compatibility

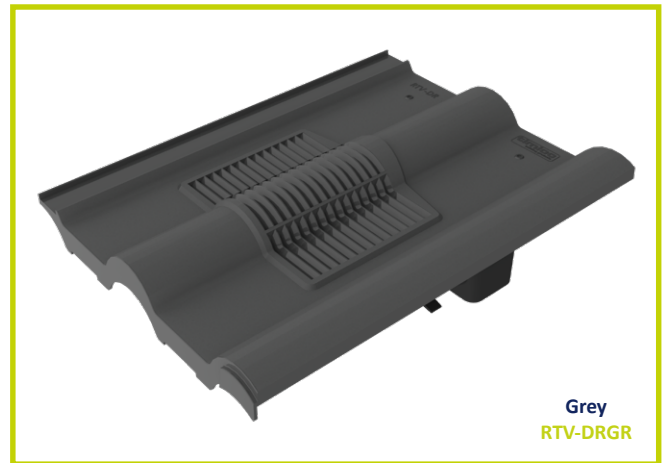
Double Roman large format tiles from all major manufacturers including:

- Marley Double Roman
- Sandtoft Double Roman
- Redland 50 Double Roman
- Lagan Double Roll
- Russell Double Roman

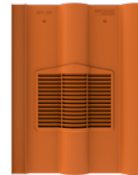
Material and Colour Choice

- Available in Terracotta, Brown, Grey and Red
- Top - UV stabilised coloured injection moulded Polypropylene with textured finish
- Base – Black injection moulded Polypropylene

Scan to view the full product page on the Timloc website



Grey
RTV-DRGR



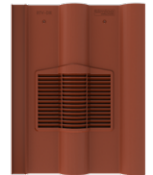
Terracotta
RTV-DRTE



Brown
RTV-DRBR

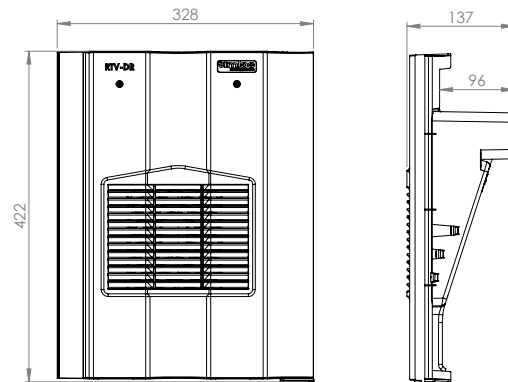


Grey
RTV-DRGR



Red
RTV-DRRD

Product Dimensions



Compatible Accessories

- Full datasheets available for all accessories

Description	Product Code	Product Image
110mm Flexi-Pipe to aid connection to ventilation duct or soil vent pipe	RTV-KIT1	
Standard adapter to attach the roof tile vent to 110mm ductwork	RTV-ADS	
Multi adapter (RTV-ADMULTI) to aid connection to 100/110/125/150mm duct sizes	RTV-ADMULTI	
RTV-KIT1 and RTV-ADS available as one kit	RTV-KIT2	

Airflow Test Data

RTV-DR (100mm duct)	
Flow Rate l/s	Static pressure difference Pa
10	2
20	8
30	17
40	30

Product Codes

Product Description	Colour	Weight	Box Quantity	Product Code	Pack Quantity	Pack Code	Pallet Quantity
Double Roman Roof Tile Vent	Terracotta	0.88kg	1	RTV-DRTE	6	RTVMULTI-DRTE	102
Double Roman Roof Tile Vent	Brown	0.88kg	1	RTV-DRBR	6	RTVMULTI-DRBR	102
Double Roman Roof Tile Vent	Grey	0.88kg	1	RTV-DRGR	6	RTVMULTI-DRGR	102
Double Roman Roof Tile Vent	Red	0.88kg	1	RTV-DRRD	6	RTVMULTI-DRRD	102

NB. RTV-DR available in single, pack or pallet quantities. For pack quantities, 6 tile vent assemblies are packaged in one large box.

Roof ventilation solutions

RTV-FE | Flat Edge Tile Vent

Profiled roof tile vent to enable ventilation directly into a roof space or connect to a ducted ventilation system

Uses

- On roofs with Flat Edge profile roof tiles
- Enables ventilation directly into a roof space
- Can also be connected to a ducted ventilation system inside the building

Features and Benefits

- Suitable for roofs with a minimum pitch of 20°
- Free ventilation area of 10,000mm²
- Sized to replace one Flat Edge tile to provide a continuous visual appearance along the roof when viewed at all levels
- Shaped to manage and channel rainwater back down onto the roof tiles and away from the vent opening
- 4mm spaced external grille to prevent rainwater ingress and keep out large insects, vermin and debris
- Integrated clips to ensure a secure fit to surrounding roof tiles
- UV stabilised top for continuous exposure to sunlight
- Lightweight and easy to handle

Relevant Standards

- BS EN 490:2011 Concrete roofing tiles and fittings for roof covering and wall cladding - product specifications (+A1:2017)
- BS 5250: 2021 Management of moisture in buildings – Code of practice
- BS 5534:2014 Slating and tiling for pitched roofs and vertical cladding – code of practice (+A2:2018)
- Manufactured to BS EN ISO 9001:2015 and BS EN ISO 14001:2015
- Complies with all relevant sections of the Building Regulations 2010
- Satisfies all relevant NHBC requirements

Compatibility

Flat Edge large format tiles from all major manufacturers including:

- Sandtoft Calderdale Edge

Material and Colour Choice

- Top - UV stabilised coloured injection moulded Polypropylene with textured finish
- Available in Terracotta, Brown, Grey, Red and Black
- Base – Black injection moulded Polypropylene

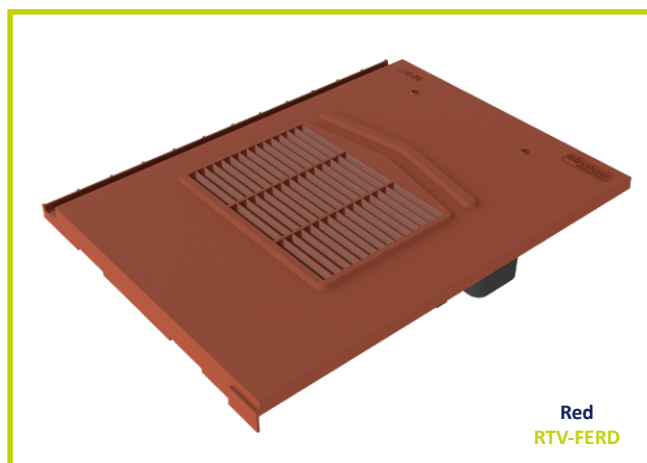
Scan to view the full product page on the Timloc website



Product Codes

Product Description	Colour	Weight	Box Quantity	Product Code	Pack Quantity	Pack Code	Pallet Quantity
Flat Edge Roof Tile Vent	Terracotta	0.83kg	1	RTV-FETE	8	RTVMULTI-FETE	136
Flat Edge Roof Tile Vent	Brown	0.83kg	1	RTV-FEBR	8	RTVMULTI-FEBR	136
Flat Edge Roof Tile Vent	Grey	0.83kg	1	RTV-FEGR	8	RTVMULTI-FEGR	136
Flat Edge Roof Tile Vent	Red	0.83kg	1	RTV-FERD	8	RTVMULTI-FERD	136
Flat Edge Roof Tile Vent	Black	0.83kg	1	RTV-FEBL	8	RTVMULTI-FEBL	136

NB. RTV-FE available in single, pack or pallet quantities. For pack quantities, 8 tile vent assemblies are packaged in one large box.



Red
RTV-FERD



Terracotta
RTV-FETE



Brown
RTV-FEBR

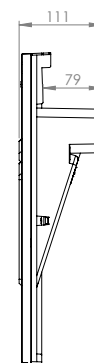
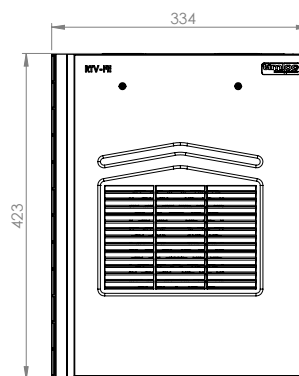


Grey
RTV-FEGR



Black
RTV-FEBL

Product Dimensions



Compatible Accessories

- Full datasheets available for all accessories

Description	Product Code	Product Image
110mm Flexi-Pipe to aid connection to ventilation duct or soil vent pipe	RTV-KIT1	
Standard adapter to attach the roof tile vent to 110mm ductwork	RTV-ADS	
Multi adapter (RTV-ADMULTI) to aid connection to 100/110/125/150mm duct sizes	RTV-ADMULTI	
RTV-KIT1 and RTV-ADS available as one kit	RTV-KIT2	

Airflow Test Data

RTV-FE (100mm duct)	
Flow Rate l/s	Static pressure difference Pa
10	2
20	10
30	21
40	38

INVENTIVE

Roof ventilation solutions

RTV-NP | Non-Profile Tile Vent

Profiled roof tile vent to enable ventilation directly into a roof space or connect to a ducted ventilation system

Uses

- On roofs with Non-Profile roof tiles
- Enables ventilation directly into a roof space
- Can also be connected to a ducted ventilation system inside the building

Features and Benefits

- Suitable for roofs with a minimum pitch of 20°
- Free ventilation area of 10,000mm²
- Sized to replace one Non-Profile tile to provide a continuous visual appearance along the roof when viewed at all levels
- Shaped to manage and channel rainwater back down onto the roof tiles and away from the vent opening
- 4mm spaced external grille to prevent rainwater ingress and keep out large insects, vermin and debris
- Integrated clips to ensure a secure fit to surrounding roof tiles
- UV stabilised top for continuous exposure to sunlight
- Lightweight and easy to handle

Relevant Standards

- BS EN 490:2011 Concrete roofing tiles and fittings for roof covering and wall cladding - product specifications (+A1:2017)
- BS 5250: 2021 Management of moisture in buildings – Code of practice
- BS 5534:2014 Slating and tiling for pitched roofs and vertical cladding – code of practice (+A2:2018)
- Manufactured to BS EN ISO 9001:2015 and BS EN ISO 14001:2015
- Complies with all relevant sections of the Building Regulations 2010
- Satisfies all relevant NHBC requirements

Compatibility

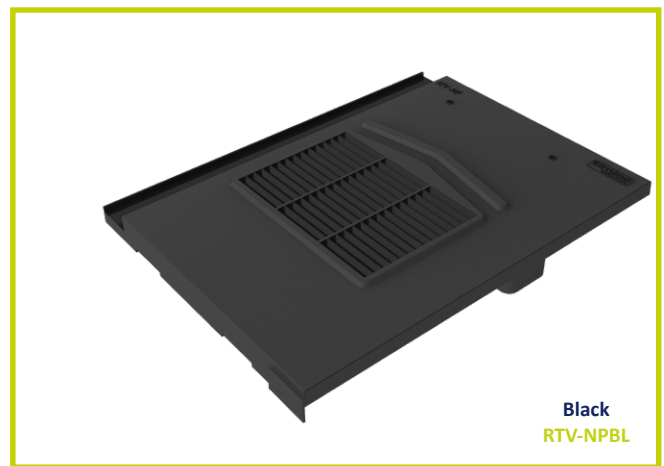
Non-Profile large format tiles from all major manufacturers including:

- Marley Modern
- Russell Grampian
- Marley Duo Modern
- Russell Highland
- Redland Mini Stonewold
- Lagan Flat
- Sandtoft Calderdale

Material and Colour Choice

- Top - UV stabilised coloured injection moulded Polypropylene with textured finish
- Available in Terracotta, Brown, Grey, Red and Black
- Base – Black injection moulded Polypropylene

Scan to view the full product page on the Timloc website



Black
RTV-NPBL



Terracotta
RTV-NPTE



Brown
RTV-NPBR

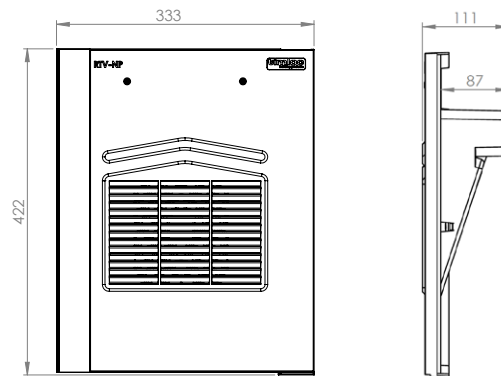


Grey
RTV-NPGR



Red
RTV-NPRD

Product Dimensions



Compatible Accessories

- Full datasheets available for all accessories

Description	Product Code	Product Image
110mm Flexi-Pipe to aid connection to ventilation duct or soil vent pipe	RTV-KIT1	
Standard adapter to attach the roof tile vent to 110mm ductwork	RTV-ADS	
Multi adapter (RTV-ADMULTI) to aid connection to 100/110/125/150mm duct sizes	RTV-ADMULTI	
RTV-KIT1 and RTV-ADS available as one kit	RTV-KIT2	

Airflow Test Data

RTV-NP (100mm duct)	
Flow Rate l/s	Static pressure difference Pa
10	2
20	10
30	21
40	38

Product Codes

Product Description	Colour	Weight	Box Quantity	Product Code	Pack Quantity	Pack Code	Pallet Quantity
Non-Profile Roof Tile Vent	Terracotta	0.86kg	1	RTV-NPTE	8	RTVMULTI-NPTE	136
Non-Profile Roof Tile Vent	Brown	0.86kg	1	RTV-NPBR	8	RTVMULTI-NPBR	136
Non-Profile Roof Tile Vent	Grey	0.86kg	1	RTV-NPGR	8	RTVMULTI-NPGR	136
Non-Profile Roof Tile Vent	Red	0.86kg	1	RTV-NPRD	8	RTVMULTI-NPRD	136
Non-Profile Roof Tile Vent	Black	0.86kg	1	RTV-NPBL	8	RTVMULTI-NPBL	136

NB. RTV-NP available in single, pack or pallet quantities. For pack quantities, 8 tile vent assemblies are packaged in one large box.

Roof ventilation solutions

RTV-TE | Thin Leading Edge Tile Vent

Profiled roof tile vent to enable ventilation directly into a roof space or connect to a ducted ventilation system

Uses

- On roofs with Thin Leading Edge profile roof tiles
- Enables ventilation directly into a roof space
- Can also be connected to a ducted ventilation system inside the building

Features and Benefits

- Suitable for roofs with a minimum pitch of 20°
- Free ventilation area of 10,000mm²
- Sized to replace one Thin Leading Edge tile to provide a continuous visual appearance along the roof when viewed at all levels
- Shaped to manage and channel rainwater back down onto the roof tiles and away from the vent opening
- 4mm spaced external grille to prevent rainwater ingress and keep out large insects, vermin and debris
- Integrated clips to ensure a secure fit to surrounding roof tiles
- UV stabilised top for continuous exposure to sunlight
- Lightweight and easy to handle

Relevant Standards

- BS EN 490:2011 Concrete roofing tiles and fittings for roof covering and wall cladding - product specifications (+A1:2017)
- BS 5250: 2021 Management of moisture in buildings – Code of practice
- BS 5534:2014 Slating and tiling for pitched roofs and vertical cladding – code of practice (+A2:2018)
- Manufactured to BS EN ISO 9001:2015 and BS EN ISO 14001:2015
- Complies with all relevant sections of the Building Regulations 2010
- Satisfies all relevant NHBC requirements

Compatibility

TLE large format tiles from all major manufacturers including:

- Marley Edgemere
- Redland Richmond
- Sandtoft TLE
- Russell Galloway
- Lagan Elite
- F P McCann Thin Flat Tile
- F P McCann Duo Thin Flat Tile

Material and Colour Choice

- Top - UV stabilised coloured injection moulded Polypropylene with textured finish
- Available in Terracotta, Brown, Grey, Red and Black
- Base – Black injection moulded Polypropylene

Scan to view the full product page on the Timloc website



Product Codes

Product Description	Colour	Weight	Box Quantity	Product Code	Pack Quantity	Pack Code	Pallet Quantity
Thin Leading Edge Roof Tile Vent	Terracotta	0.81kg	1	RTV-TETE	8	RTVMULTI-TETE	136
Thin Leading Edge Roof Tile Vent	Brown	0.81kg	1	RTV-TEBR	8	RTVMULTI-TEBR	136
Thin Leading Edge Roof Tile Vent	Grey	0.81kg	1	RTV-TEGR	8	RTVMULTI-TEGR	136
Thin Leading Edge Roof Tile Vent	Red	0.81kg	1	RTV-TERD	8	RTVMULTI-TERD	136
Thin Leading Edge Roof Tile Vent	Black	0.81kg	1	RTV-TEBL	8	RTVMULTI-TEBL	136

NB. RTV-TE available in single, pack or pallet quantities. For pack quantities, 8 tile vent assemblies are packaged in one large box.



Terracotta
RTV-TETE



Brown
RTV-TEBR



Grey
RTV-TEGR

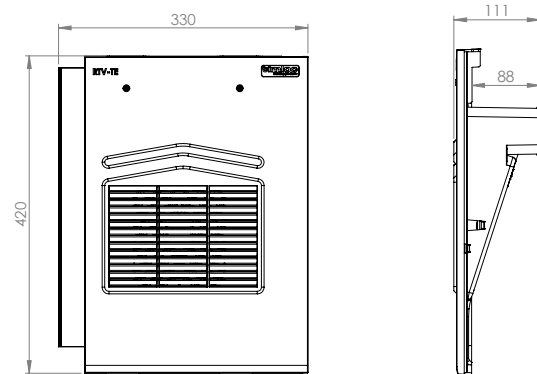


Red
RTV-TERD



Black
RTV-TEBL

Product Dimensions



Compatible Accessories

- Full datasheets available for all accessories

Description	Product Code	Product Image
110mm Flexi-Pipe to aid connection to ventilation duct or soil vent pipe	RTV-KIT1	
Standard adapter to attach the roof tile vent to 110mm ductwork	RTV-ADS	
Multi adapter (RTV-ADMULTI) to aid connection to 100/110/125/150mm duct sizes	RTV-ADMULTI	
RTV-KIT1 and RTV-ADS available as one kit	RTV-KIT2	

Airflow Test Data

RTV-TE (100mm duct)	
Flow Rate l/s	Static pressure difference Pa
10	2
20	10
30	21
40	38

Roof ventilation solutions

RTV-IP | Interlocking Plain Tile Vent

Interlocking Plain roof tile vent to enable ventilation directly into a roof space or connect to a ducted ventilation system

Uses

- On roofs with Interlocking Plain profile roof tiles
- Enables ventilation directly into a roof space
- Can also be connected to a ducted ventilation system inside the building

Features and Benefits

- Suitable for roofs with a minimum pitch of 22.5°
- Free ventilation area of 6,000mm²
- Sized to replace one Interlocking Plain tile to provide a continuous visual appearance along the roof when viewed at all levels
- Shaped to manage and channel rainwater back down onto the roof tiles and away from the vent opening
- 4mm spaced external grille to prevent rainwater ingress and keep out large insects, vermin and debris
- UV stabilised top for continuous exposure to sunlight
- Lightweight and easy to handle

Relevant Standards

- BS EN 490:2011 Concrete roofing tiles and fittings for roof covering and wall cladding - product specifications (+A1:2017)
- BS 5250: 2021 Management of moisture in buildings – Code of practice
- BS 5534:2014 Slating and tiling for pitched roofs and vertical cladding – code of practice (+A2:2018)
- Manufactured to BS EN ISO 9001:2015 and BS EN ISO 14001:2015
- Complies with all relevant sections of the Building Regulations 2010
- Satisfies all relevant NHBC requirements

Compatibility

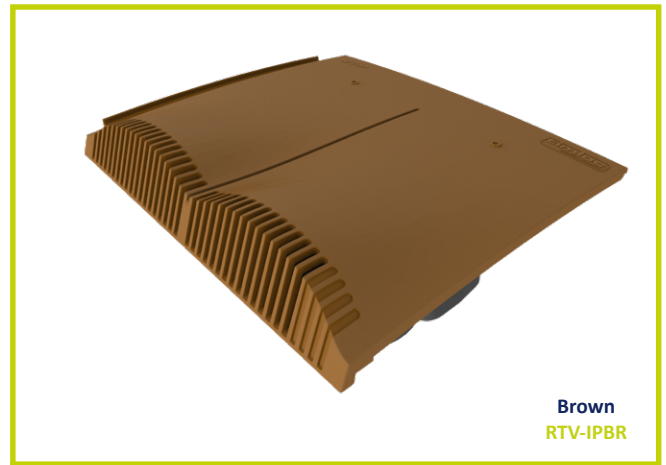
Interlocking Plain tiles from all major manufacturers including:

- Marley Ashmore
- Redland Duoplain
- Forticrete Gemini

Material and Colour Choice

- Top - UV stabilised coloured injection moulded Polypropylene with textured finish
- Available in Terracotta, Brown, Grey and Red
- Base – Black injection moulded Polypropylene

Scan to view the full product page on the Timloc website



Brown
RTV-IPBR



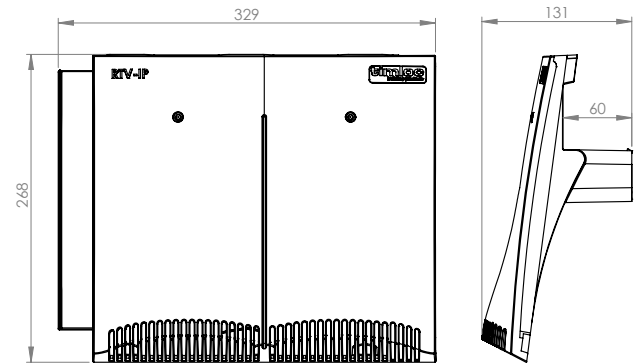
Terracotta
RTV-IPTE

Brown
RTV-IPBR

Grey
RTV-IPGR

Red
RTV-IPRD

Product Dimensions



Compatible Accessories

- Full datasheets available for all accessories

Description	Product Code	Product Image
110mm Flexi-Pipe to aid connection to ventilation duct or soil vent pipe	RTV-KIT1	
Plain adapter to attach the roof tile vent to 110mm ductwork	RTV-ADP	
Multi adapter (RTV-ADMULTI) to aid connection to 100/110/125/150mm duct sizes	RTV-ADMULTI	
RTV-KIT1 and RTV-ADP available as one kit	RTV-KIT3	

Airflow Test Data

RTV-IP (100mm duct)	
Flow Rate l/s	Static pressure difference Pa
3	2
5	6
10	20
15	45

Product Codes

Product Description	Colour	Weight	Box Quantity	Product Code	Pack Quantity	Pack Code	Pallet Quantity
Interlocking Plain Roof Tile Vent	Terracotta	0.59kg	1	RTV-IPTE	12	RTVMULTI-IPTE	204
Interlocking Plain Roof Tile Vent	Brown	0.59kg	1	RTV-IPBR	12	RTVMULTI-IPBR	204
Interlocking Plain Roof Tile Vent	Grey	0.59kg	1	RTV-IPGR	12	RTVMULTI-IPGR	204
Interlocking Plain Roof Tile Vent	Red	0.59kg	1	RTV-IPRD	12	RTVMULTI-IPRD	204

NB. RTV-IP available in single, pack or pallet quantities. For pack quantities, 12 tile vent assemblies are packaged in one large box.

Roof ventilation solutions

RTV-P | Plain Tile Vent

Plain roof tile vent to enable ventilation directly into a roof space or connect to a ducted ventilation system

Uses

- On roofs with Plain roof tiles
- Enables ventilation directly into a roof space
- Can also be connected to a ducted ventilation system inside the building

Features and Benefits

- Suitable for roofs with a minimum pitch of 35°
- Free ventilation area of 7,000mm²
- Sized to replace three plain tiles to provide a continuous visual appearance along the roof when viewed at all levels
- Shaped to manage and channel rainwater back down onto the roof tiles and away from the vent opening
- 4mm spaced external grille to prevent rainwater ingress and keep out large insects, vermin and debris
- UV stabilised top for continuous exposure to sunlight
- Lightweight and easy to handle

Relevant Standards

- BS EN 490:2011 Concrete roofing tiles and fittings for roof covering and wall cladding - product specifications (+A1:2017)
- BS 5250: 2021 Management of moisture in buildings – Code of practice
- BS 5534:2014 Slating and tiling for pitched roofs and vertical cladding – code of practice (+A2:2018)
- Manufactured to BS EN ISO 9001:2015 and BS EN ISO 14001:2015
- Complies with all relevant sections of the Building Regulations 2010
- Satisfies all relevant NHBC requirements

Compatibility

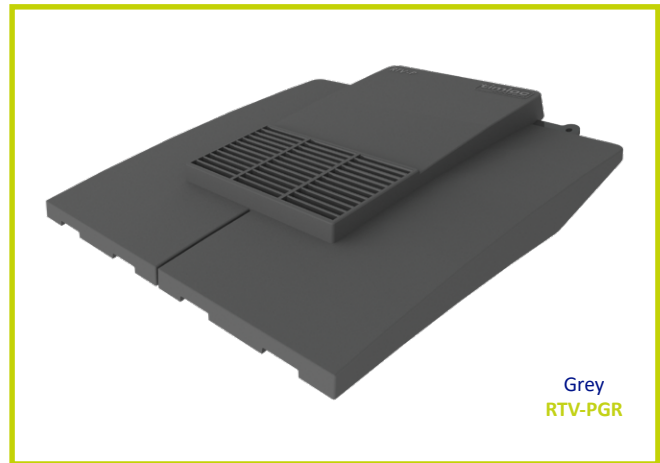
Plain tiles from all major manufacturers including:

- Redland Rosemary
- Russell Traditional Plain
- Marley Plain
- Sandtoft Humber Plain

Material and Colour Choice

- Available in Terracotta, Brown, Grey and Red
- Top - UV stabilised coloured injection moulded Polypropylene with textured finish
- Base – Black injection moulded Polypropylene

Scan to view the full product page on the Timloc website



Grey
RTV-PGR



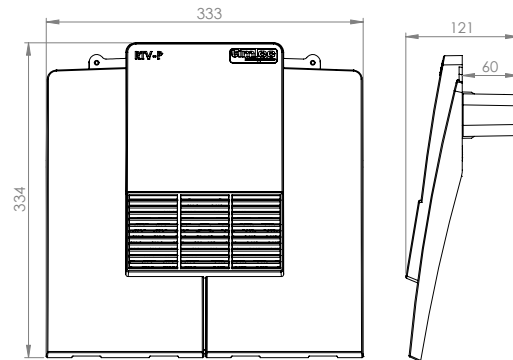
Terracotta
RTV-PTE

Brown
RTV-PBR

Grey
RTV-PGR

Red
RTV-PRD

Product Dimensions



Compatible Accessories

- Full datasheets available for all accessories

Description	Product Code	Product Image
110mm Flexi-Pipe to aid connection to ventilation duct or soil vent pipe	RTV-KIT1	
Plain adapter to attach the roof tile vent to 110mm ductwork	RTV-ADP	
Multi adapter (RTV-ADMULTI) to aid connection to 100/110/125/150mm duct sizes	RTV-ADMULTI	
RTV-KIT1 and RTV-ADP available as one kit	RTV-KIT3	

Airflow Test Data

RTV-P (100mm duct)	
Flow Rate l/s	Static pressure difference Pa
5	2
10	9
15	19
20	34

Product Codes

Product Description	Colour	Weight	Box Quantity	Product Code	Pack Quantity	Pack Code	Pallet Quantity
Plain Roof Tile Vent	Terracotta	0.7kg	1	RTV-PTE	14	RTVMULTI-PTE	238
Plain Roof Tile Vent	Brown	0.7kg	1	RTV-PBR	14	RTVMULTI-PBR	238
Plain Roof Tile Vent	Grey	0.7kg	1	RTV-PGR	14	RTVMULTI-PGR	238
Plain Roof Tile Vent	Red	0.7kg	1	RTV-PRD	14	RTVMULTI-PRD	238

NB. RTV-P available in single, pack or pallet quantities. For pack quantities, 14 tile vent assemblies are packaged in one large box.

Roof ventilation solutions

RTV-LPP | Low Profile Plain Tile Vent

Plain roof tile vent to enable ventilation directly into a roof space or connect to a ducted ventilation system

Uses

- On roofs with Plain roof tiles
- Enables ventilation directly into a roof space
- Can also be connected to a ducted ventilation system inside the building

Features and Benefits

- Suitable for roofs with a minimum pitch of 35°
- Free ventilation area of 6,100mm²
- Sized to replace 2 plain tiles to provide a continuous visual appearance along the roof when viewed at all levels
- Shaped to manage rainwater back down onto the roof and away from the vent opening via the three drainage channels
- Internal grille to keep out large insects, vermin and debris
- UV stabilised for continuous exposure to sunlight
- Lightweight and easy to handle

Relevant Standards

- BS EN 490:2011 Concrete roofing tiles and fittings for roof covering and wall cladding - product specifications (+A1:2017)
- BS 5250: 2021 Management of moisture in buildings – Code of practice
- BS 5534:2014 Slating and tiling for pitched roofs and vertical cladding – code of practice (+A2:2018)
- Manufactured to BS EN ISO 9001:2015 and BS EN ISO 14001:2015
- Complies with all relevant sections of the Building Regulations 2010
- Satisfies all relevant NHBC requirements

Compatibility

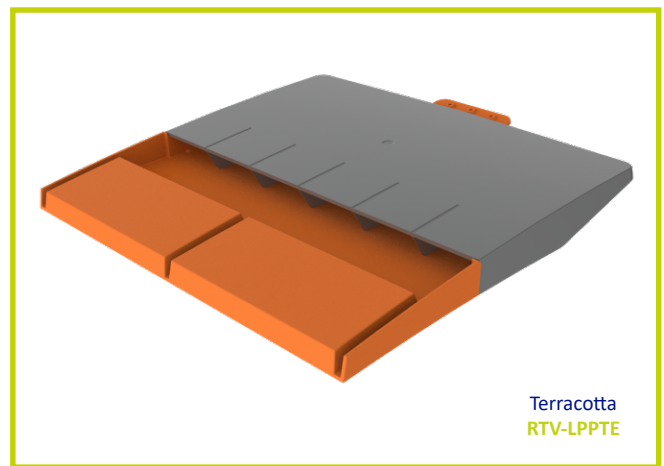
Plain tiles from all major manufacturers including:

- Redland Rosemary
- Marley Plain
- Russell Traditional Plain
- Sandtoft Humber Plain

Material and Colour Choice

- Top - UV stabilised coloured injection moulded Polypropylene with textured finish
- Available in Terracotta, Brown, Grey and Red
- Base – Black injection moulded Polypropylene

Scan to view the full product page on the Timloc website



Terracotta
RTV-LPPTE



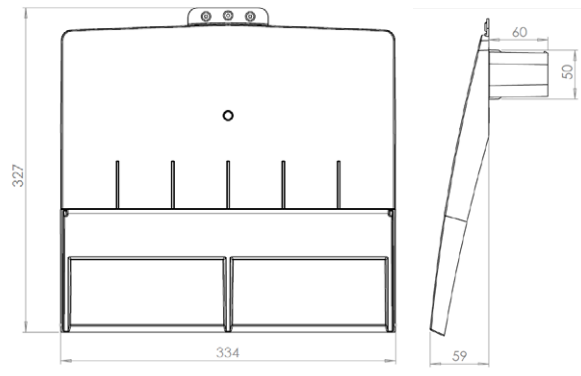
Terracotta
RTV-LPPTE

Brown
RTV-LPPBR

Grey
RTV-LPPGR

Red
RTV-LPPRD

Product Dimensions



Compatible Accessories

- Full datasheets available for all accessories

Description	Product Code	Product Image
110mm Flexi-Pipe to aid connection to ventilation duct or soil vent pipe	RTV-KIT1	
Plain adapter to attach the roof tile vent to 110mm ductwork	RTV-ADP	
Multi adapter (RTV-ADMULTI) to aid connection to 100/110/125/150mm duct sizes	RTV-ADMULTI	
RTV-KIT1 and RTV-ADP available as one kit	RTV-KIT3	

Airflow Test Data

RTV-LPP (100mm duct)	
Flow Rate l/s	Static pressure difference Pa
3	1
10	9
18	26
25	51

Product Codes

Product Description	Colour	Weight	Box Quantity	Product Code	Pack Quantity	Pack Code
Low Profile Plain Roof Tile Vent	Terracotta	0.7kg	1	RTV-LPPTE	14	RTVMULTI-LPPTE
Low Profile Plain Roof Tile Vent	Brown	0.7kg	1	RTV-LPPBR	14	RTVMULTI-LPPBR
Low Profile Plain Roof Tile Vent	Grey	0.7kg	1	RTV-LPPGR	14	RTVMULTI-LPPGR
Low Profile Plain Roof Tile Vent	Red	0.7kg	1	RTV-LPPRD	14	RTVMULTI-LPPRD

NB. RTV-LPP available in single, pack or pallet quantities. For pack quantities, 14 tile vent assemblies are packaged in one large box.

Roof ventilation solutions

RTV-SLIP | Slip Plain Tile Vent

Plain roof tile vent to enable ventilation directly into a roof space or connect to a ducted ventilation system

Uses

- On roofs with Plain roof tiles
- Enables ventilation directly into a roof space
- Can also be connected to a ducted ventilation system inside the building

Features and Benefits

- Suitable for roofs with a minimum pitch of 35°
- Free ventilation area of 6,100mm²
- Sized to replace 2 plain tiles to provide a continuous visual appearance along the roof when viewed at all levels
- Shaped to manage rainwater back down onto the roof and away from the vent opening via the three drainage channels
- Internal grille to keep out large insects, vermin and debris
- UV stabilised for continuous exposure to sunlight
- Lightweight and easy to handle

Relevant Standards

- BS EN 490:2011 Concrete roofing tiles and fittings for roof covering and wall cladding - product specifications (+A1:2017)
- BS 5250: 2021 Management of moisture in buildings – Code of practice
- BS 5534:2014 Slating and tiling for pitched roofs and vertical cladding – code of practice (+A2:2018)
- Manufactured to BS EN ISO 9001:2015 and BS EN ISO 14001:2015
- Complies with all relevant sections of the Building Regulations 2010
- Satisfies all relevant NHBC requirements

Compatibility

Plain tiles from all major manufacturers including:

- Redland Rosemary
- Marley Plain
- Russell Traditional Plain
- Sandtoft Humber Plain

Material and Colour Choice

- Top - UV stabilised coloured injection moulded Polypropylene with textured finish
- Available in Terracotta, Brown, Grey and Red
- Base – Black injection moulded Polypropylene

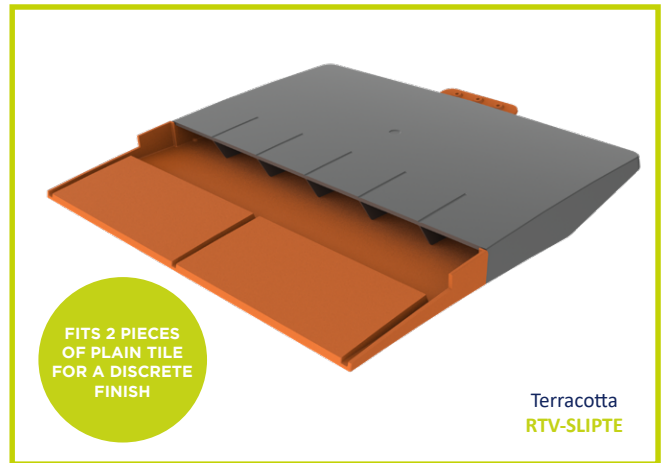
Scan to view the full product page on the Timloc website



Product Codes

Product Description	Colour	Weight	Box Quantity	Product Code	Pack Quantity	Pack Code
Slip Plain Roof Tile Vent	Terracotta	0.7kg	1	RTV-SLIPTE	14	RTVMULTI-SLIPTE
Slip Plain Roof Tile Vent	Brown	0.7kg	1	RTV-SLIPBR	14	RTVMULTI-SLIPBR
Slip Plain Roof Tile Vent	Grey	0.7kg	1	RTV-SLIPGR	14	RTVMULTI-SLIPGR
Slip Plain Roof Tile Vent	Red	0.7kg	1	RTV-SLIPRD	14	RTVMULTI-SLIPRD

NB. RTV-SLIP available in single, pack or pallet quantities. For pack quantities, 14 tile vent assemblies are packaged in one large box.



FITS 2 PIECES OF PLAIN TILE FOR A DISCRETE FINISH

Terracotta
RTV-SLIPTE



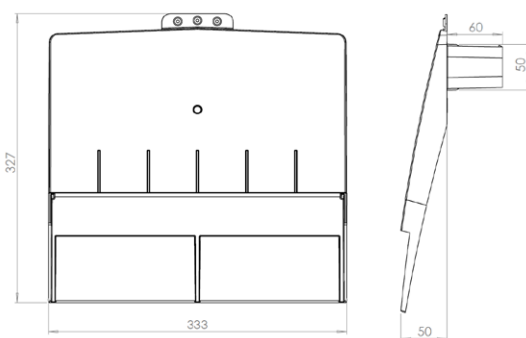
Terracotta
RTV-SLIPTE

Brown
RTV-SLIPBR

Grey
RTV-SLIPGR

Red
RTV-SLIPRD

Product Dimensions



Compatible Accessories

- Full datasheets available for all accessories

Description	Product Code	Product Image
110mm Flexi-Pipe to aid connection to ventilation duct or soil vent pipe	RTV-KIT1	
Plain adapter to attach the roof tile vent to 110mm ductwork	RTV-ADP	
Multi adapter (RTV-ADMULTI) to aid connection to 100/110/125/150mm duct sizes	RTV-ADMULTI	
RTV-KIT1 and RTV-ADP available as one kit	RTV-KIT3	

Airflow Test Data

RTV-SLIP (100mm duct)	
Flow Rate l/s	Static pressure difference Pa
3	1
10	9
18	26
25	51

INVENTIVE

Roof ventilation solutions

RTV-SP | Single Pantile Tile Vent

Profiled roof tile vent to enable ventilation directly into a roof space or connect to a ducted ventilation system

Uses

- On roofs with Single Pantile profile roof tiles
- Enables ventilation directly into a roof space
- Can also be connected to a ducted ventilation system inside the building

Features and Benefits

- Suitable for roofs with a minimum pitch of 20°
- Free ventilation area of 5,000mm²
- Sized to replace one Single Pantile tile to provide a continuous visual appearance along the roof when viewed at all levels
- Shaped to manage and channel rainwater back down onto the roof tiles and away from the vent opening
- Provides a 110mm duct connection as standard
- 4mm spaced external grille to prevent rainwater ingress and keep out large insects, vermin and debris
- Integrated clips to ensure a secure fit to surrounding roof tiles
- UV stabilised top for continuous exposure to sunlight
- Lightweight and easy to handle

Relevant Standards

- BS EN 490:2011 Concrete roofing tiles and fittings for roof covering and wall cladding - product specifications (+A1:2017)
- BS 5250: 2021 Management of moisture in buildings – Code of practice
- BS 5534:2014 Slating and tiling for pitched roofs and vertical cladding – code of practice (+A2:2018)
- Manufactured to BS EN ISO 9001:2015 and BS EN ISO 14001:2015
- Complies with all relevant sections of the Building Regulations 2010
- Satisfies all relevant NHBC requirements

Compatibility

Single Pantile small format tiles from all major manufacturers including:

- Marley Anglia
- Redland Fenland Pantile
- Sandtoft Shire

Material and Colour Choice

- Top - UV stabilised coloured injection moulded Polypropylene with textured finish
- Available in Terracotta, Brown, Grey and Red
- Base – Black injection moulded Polypropylene

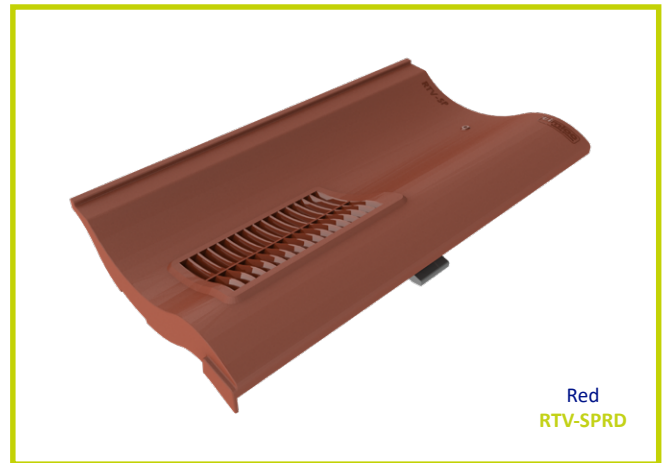


Scan to view the full product page on the Timloc website

Product Codes

Product Description	Colour	Weight	Box Quantity	Product Code	Pack Quantity	Pack Code	Pallet Quantity
Single Pantile Roof Tile Vent	Terracotta	0.62kg	1	RTV-SPTE	11	RTVMULTI-SPTE	187
Single Pantile Roof Tile Vent	Brown	0.62kg	1	RTV-SPBR	11	RTVMULTI-SPBR	187
Single Pantile Roof Tile Vent	Grey	0.62kg	1	RTV-SPGR	11	RTVMULTI-SPGR	187
Single Pantile Roof Tile Vent	Red	0.62kg	1	RTV-SPRD	11	RTVMULTI-SPRD	187

NB. RTV-SP available in single, pack or pallet quantities. For pack quantities, 11 tile vent assemblies are packaged in one large box.



Red
RTV-SPRD



Terracotta
RTV-SPTE



Brown
RTV-SPBR

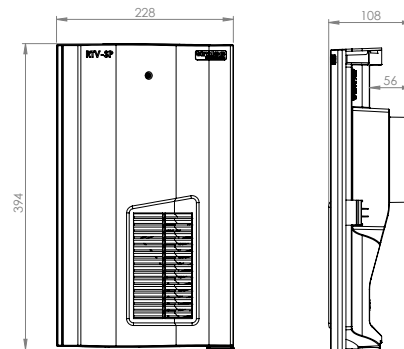


Grey
RTV-SPGR



Red
RTV-SPRD

Product Dimensions



Compatible Accessories

- Full datasheets available for all accessories

Description	Product Code	Product Image
110mm Flexi-Pipe to aid connection to ventilation duct or soil vent pipe	RTV-KIT1	
Multi adapter (RTV-ADMULTI) to aid connection to 100/110/125/150mm duct sizes	RTV-ADMULTI	

Airflow Test Data

RTV-SP (100mm duct)	
Flow Rate l/s	Static pressure difference Pa
5	3
10	12
15	26
20	45

INVENTIVE

Roof ventilation solutions

RTV-MC | Mini Castellated Tile Vent

Profiled roof tile vent to enable ventilation directly into a roof space or connect to a ducted ventilation system

Uses

- On roofs with Mini Castellated roof tiles
- Enables ventilation directly into a roof space
- Can also be connected to a ducted ventilation system inside the building

Features and Benefits

- Suitable for roofs with a minimum pitch of 17.5°
- Free ventilation area of 5,000mm².
- Sized to replace one Mini Castellated tile to provide a continuous visual appearance along the roof when viewed at all levels
- Provides a 110mm duct connection as standard
- Shaped to manage and channel rainwater back down onto the roof tiles and away from the vent opening
- 4mm spaced external grille to prevent rainwater ingress and keep out large insects, vermin and debris
- Integrated clips to ensure a secure fit to surrounding roof tiles
- UV stabilised top for continuous exposure to sunlight
- Lightweight and easy to handle

Relevant Standards

- BS EN 490:2011 Concrete roofing tiles and fittings for roof covering and wall cladding - product specifications (+A1:2017)
- BS 5250: 2021 Management of moisture in buildings – Code of practice
- BS 5534:2014 Slating and tiling for pitched roofs and vertical cladding – code of practice (+A2:2018)
- Manufactured to BS EN ISO 9001:2015 and BS EN ISO 14001:2015
- Complies with all relevant sections of the Building Regulations 2010
- Satisfies all relevant NHBC requirements

Compatibility

Mini Castellated small format tiles from all major manufacturers including:

- Marley Ludlow Plus
- Redland 49
- Sandtoft Standard Pattern
- Forticrete V2

Material and Colour Choice

- Top - UV stabilised coloured injection moulded Polypropylene with textured finish
- Available in Terracotta, Brown, Grey and Red
- Base – Black injection moulded Polypropylene

Scan to view the full product page on the Timloc website



Product Codes

Product Description	Colour	Weight	Box Quantity	Product Code	Pack Quantity	Pack Code	Pallet Quantity
Mini Castellated Roof Tile Vent	Terracotta	0.63kg	1	RTV-MCTE	14	RTVMULTI-MCTE	238
Mini Castellated Roof Tile Vent	Brown	0.63kg	1	RTV-MCBR	14	RTVMULTI-MCBR	238
Mini Castellated Roof Tile Vent	Grey	0.63kg	1	RTV-MCGR	14	RTVMULTI-MCGR	238
Mini Castellated Roof Tile Vent	Red	0.63kg	1	RTV-MCRD	14	RTVMULTI-MCRD	238

NB. RTV-MC available in single, pack or pallet quantities. For pack quantities, 14 tile vent assemblies are packaged in one large box.



Terracotta
RTV-MCTE



Brown
RTV-MCBR

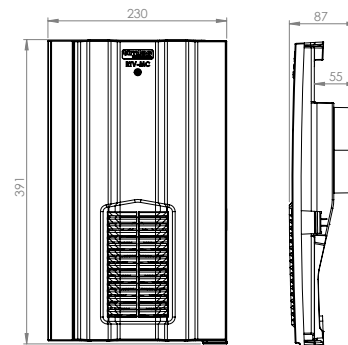


Grey
RTV-MCGR



Red
RTV-MCRD

Product Dimensions



Compatible Accessories

- Full datasheets available for all accessories

Description	Product Code	Product Image
110mm Flexi-Pipe to aid connection to ventilation duct or soil vent pipe	RTV-KIT1	
Multi adapter (RTV-ADMULTI) to aid connection to 100/110/125/150mm duct sizes	RTV-ADMULTI	

Airflow Test Data

RTV-MC (100mm duct)	
Flow Rate l/s	Static pressure difference Pa
5	4
10	14
15	30
20	51

INVENTIVE

Roof ventilation solutions

RTV-UNI | Universal Vent 20,000mm²

Universal roof vent to enable ventilation directly into a roof space or connect to a ducted ventilation system

Uses

- On roofs with any type of tile or slate roof covering
- Enables ventilation directly into a roof space
- Can also be connected to a ducted ventilation system inside the building

Features and Benefits

- Suitable for roofs with a minimum pitch of 12.5°
- Max free ventilation area of 20,000mm² when cut at 170mm diameter
- Max free ventilation area of 16,000mm² when cut at 150mm diameter
- Max free ventilation area of 11,000mm² when cut at 125mm diameter
- Max free ventilation area of 8,400mm² when cut at 110mm diameter
- Designed to provide ventilation through all types and profiles of tile or slate
- Integrated lead alternative flashing provides a customisable fit
- Shaped to manage and channel rainwater back down onto the roof tiles and away from the vent opening
- UV stabilised top for continuous exposure to sunlight
- Lightweight and easy to handle

Relevant Standards

- BS EN 490:2011 Concrete roofing tiles and fittings for roof covering and wall cladding - product specifications (+A1:2017)
- BS 5250: 2021 Management of moisture in buildings – Code of practice
- BS 5534:2014 Slating and tiling for pitched roofs and vertical cladding – code of practice (+A2:2018)
- Manufactured to BS EN ISO 9001:2015 and BS EN ISO 14001:2015
- Complies with all relevant sections of the Building Regulations 2010
- Satisfies all relevant NHBC requirements

Compatibility

The alternative lead flashing sheet allows the Universal Roof Tile Vent to be installed onto all types of tile or slate roof covering.

Material and Colour Choice

- Top-UV stabilised coloured injection moulded Polypropylene with textured finish
- Available in Terracotta, Brown, Grey, Red and Black
- DEKS Fast Flash Self Adhesive Lead Alternative in Black*

*Visit the [DEKS website](#) for further information and for [installation advice](#)



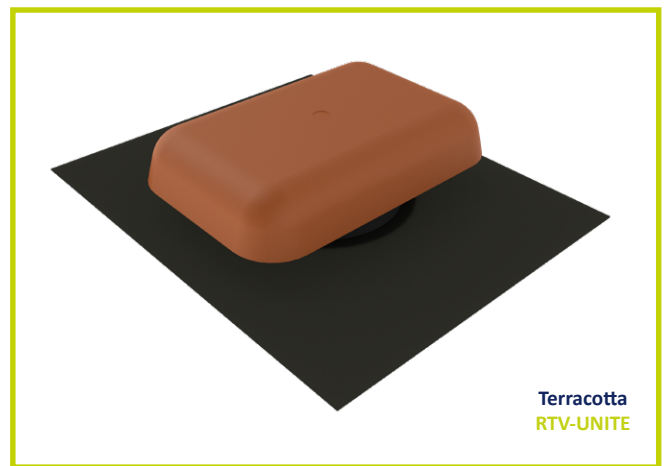
Scan to view the full product page on the Timloc website



Product Codes

Product Description	Colour	Weight	Box Quantity	Product Code	Pack Quantity	Pack Code	Pallet Quantity
Universal Roof Tile Vent	Terracotta	1.57kg	1	RTV-UNITE	4	RTVMULTI-UNITE	60
Universal Roof Tile Vent	Brown	1.57kg	1	RTV-UNIBR	4	RTVMULTI-UNIBR	60
Universal Roof Tile Vent	Grey	1.57kg	1	RTV-UNIGR	4	RTVMULTI-UNIGR	60
Universal Roof Tile Vent	Red	1.57kg	1	RTV-UNIRD	4	RTVMULTI-UNIRD	60
Universal Roof Tile Vent	Black	1.57kg	1	RTV-UNIBL	4	RTVMULTI-UNIBL	60

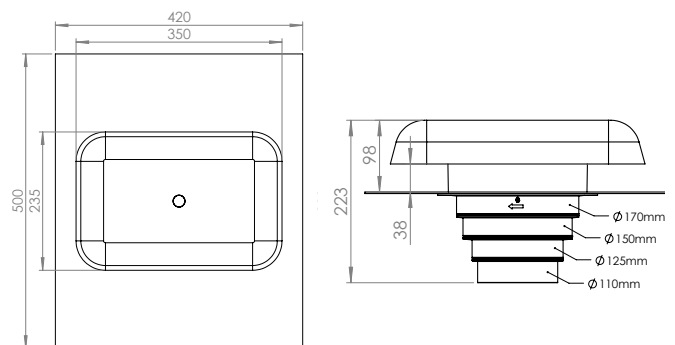
NB. RTV-UNI available in single, pack or pallet quantities. For pack quantities, 4 tile vent assemblies are packaged in one large box.



Terracotta
RTV-UNITE



Product Dimensions



Compatible Accessories

- Full datasheets available for all accessories

Description	Product Code	Product Image
110mm Flexi-Pipe to aid connection to ventilation duct or soil vent pipe	RTV-KIT1	

Airflow Test Data

Flow Rate l/s	RTV-UNI (100mm duct)	RTV-UNI (125mm duct)
	Static pressure difference Pa	
15	1	1
30	2	3
45	4	7
60	6	12
75	10	19
90	14	27

Roof ventilation solutions

RTV-UNI2 | Universal Vent 22,000mm²

Universal roof vent to enable ventilation directly into a roof space or connect to a ducted ventilation system

Uses

- On roofs with any type of tile or slate roof covering
- Enables ventilation directly into a roof space
- Can also be connected to a ducted ventilation system inside the building

Features and Benefits

- Suitable for roofs with a minimum pitch of 12.5°
- Max free ventilation area of 22,000mm² when cut at 170mm diameter
- Max free ventilation area of 16,000mm² when cut at 150mm diameter
- Max free ventilation area of 11,000mm² when cut at 125mm diameter
- Max free ventilation area of 8,400mm² when cut at 110mm diameter
- Designed to provide ventilation through all types of tile or slate
- Integrated lead alternative flashing provides a customisable fit
- Shaped to manage and channel rainwater back down onto the roof tiles and away from the vent opening
- UV stabilised top for continuous exposure to sunlight
- Lightweight and easy to handle

Relevant Standards

- BS EN 490:2011 Concrete roofing tiles and fittings for roof covering and wall cladding - product specifications (+A1:2017)
- BS 5250: 2021 Management of moisture in buildings – Code of practice
- BS 5534:2014 Slating and tiling for pitched roofs and vertical cladding – code of practice (+A2:2018)
- Manufactured to BS EN ISO 9001:2015 and BS EN ISO 14001:2015
- Complies with all relevant sections of the Building Regulations 2010
- Satisfies all relevant NHBC requirements

Compatibility

The alternative lead flashing sheet allows the Universal Roof Tile Vent to be installed onto all types of tile or slate roof covering.

Material and Colour Choice

- Top-UV stabilised coloured injection moulded Polypropylene with textured finish
- Available in Terracotta, Brown, Grey, Red and Black
- DEKS Fast Flash Self Adhesive Lead Alternative in Black*

*Visit the [DEKS website](#) for further information and for [installation advice](#)



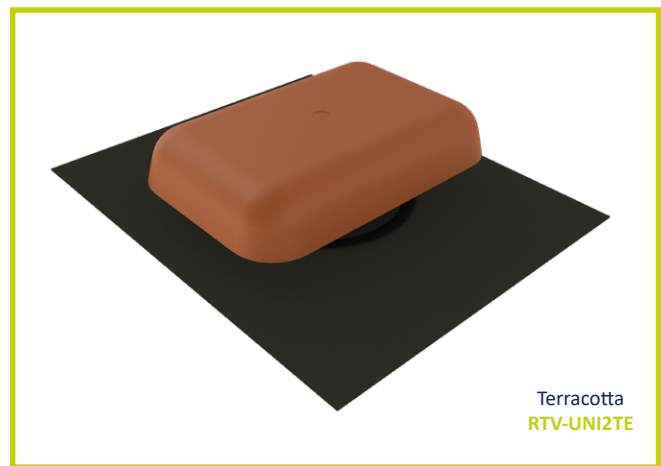
Scan to view the full product page on the Timloc website



Product Codes

Product Description	Colour	Weight	Box Quantity	Product Code	Pack Quantity	Pack Code	Pallet Quantity
Universal Roof Tile Vent	Terracotta	1.57kg	1	RTV-UNI2TE	4	RTVMULTI-UNI2TE	60
Universal Roof Tile Vent	Brown	1.57kg	1	RTV-UNI2BR	4	RTVMULTI-UNI2BR	60
Universal Roof Tile Vent	Grey	1.57kg	1	RTV-UNI2GR	4	RTVMULTI-UNI2GR	60
Universal Roof Tile Vent	Red	1.57kg	1	RTV-UNI2RD	4	RTVMULTI-UNI2RD	60
Universal Roof Tile Vent	Black	1.57kg	1	RTV-UNI2BL	4	RTVMULTI-UNI2BL	60

NB. RTV-UNI2 available in single, pack or pallet quantities. For pack quantities, 4 tile vent assemblies are packaged in one large box.



Terracotta
RTV-UNI2TE



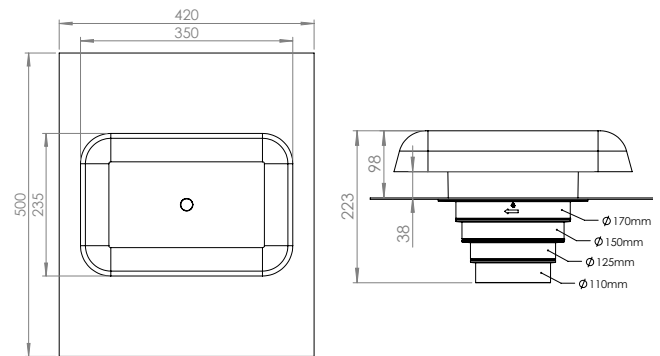
Brown
RTV-UNI2BR

Grey
RTV-UNI2GR

Red
RTV-UNI2RD

Black
RTV-UNI2BL

Product Dimensions



Compatible Accessories

- Full datasheets available for all accessories

Description	Product Code	Product Image
110mm Flexi-Pipe to aid connection to ventilation duct or soil vent pipe	RTV-KIT1	

Airflow Test Data

Flow Rate l/s	RTV-UNI (100mm duct)	RTV-UNI (125mm duct)
	Static pressure difference Pa	
15	1	1
30	2	3
45	4	8
60	7	13
75	11	20
90	15	29

INVENTIVE

Roof ventilation solutions

RTV-IS | Inline Slate Vent

Inline Slate Vent to enable ventilation directly into a roof space or connect to a ducted ventilation system

Uses

- On roofs with Natural or Synthetic Slates
- Enables ventilation directly into a roof space
- Can also be connected to a ducted ventilation system inside the building

Features and Benefits

- Suitable for roofs with a minimum pitch of 22.5°
- Free ventilation area of 9,450mm².
- Sized to replace one slate to provide a continuous visual appearance along the roof when viewed at all levels
- Shaped to manage and channel rainwater back down onto the roof tiles and away from the vent opening
- Provides a 110mm duct connection as standard with the optional RTV-ADIS duct adapter
- 4mm spaced external grille to prevent rainwater ingress and keep out large insects, vermin and debris
- Lightweight and easy to handle

Relevant Standards

- BS EN 490:2011 Concrete roofing tiles and fittings for roof covering and wall cladding - product specifications (+A1:2017)
- BS 5250: 2021 Management of moisture in buildings – Code of practice
- BS 5534:2014 Slating and tiling for pitched roofs and vertical cladding – code of practice (+A2:2018)
- Manufactured to BS EN ISO 9001:2015 and BS EN ISO 14001:2015
- Complies with all relevant sections of the Building Regulations 2010
- Satisfies all relevant NHBC requirements

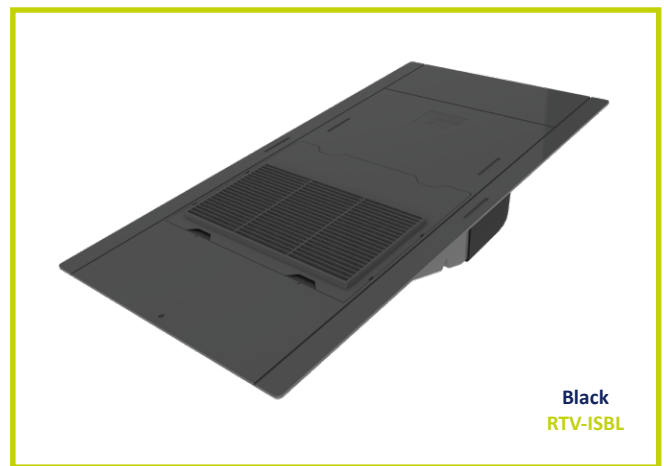
Compatibility

Natural or Synthetic slates in sizes 600mm x 300mm or 500mm x 250mm from all major manufacturers.

Material and Colour Choice

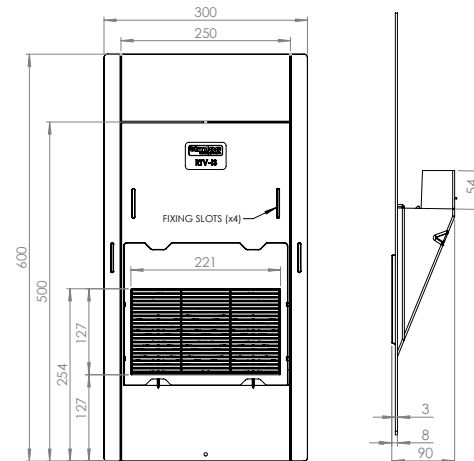
- Injection moulded Polypropylene with textured finish
- Available in Black

Scan to view the full product page on the Timloc website



Black
RTV-ISBL

Product Dimensions



Compatible Accessories

- Full datasheets available for all accessories

Description	Product Code	Product Image
110mm Flexi-Pipe to aid connection to ventilation duct or soil vent pipe	RTV-KIT1	
Inline Slate adapter to attach the roof tile vent to 110mm ductwork	RTV-ADIS	
Multi adapter (RTV-ADMULTI) to aid connection to 100/110/125/150mm duct sizes	RTV-ADMULTI	
RTV-KIT1 and RTV-ADIS available as one kit	RTV-KIT4	

Airflow Test Data

RTV-IS (100mm duct)	
Flow Rate l/s	Static pressure difference Pa
10	2
20	8
30	19
40	34

Product Codes

Product Description	Colour	Weight	Box Quantity	Product Code	Pack Quantity	Pack Code	Pallet Quantity
Inline Slate Vent	Black	0.78kg	1	RTV-ISBL	5	RTVMULTI-ISBL	120

NB. RTV-ISBL available in single, pack or pallet quantities. For pack quantities, 5 Inline Slate vent assemblies are packaged in one large box.

Roof ventilation solutions

RTV-SIS | Small Inline Slate Vent

Small Inline Slate Vent to enable ventilation directly into a roof space or connect to a ducted ventilation system

Uses

- On roofs with Natural or Synthetic Slates
- Enables ventilation directly into a roof space
- Can also be connected to a ducted ventilation system inside the building

Features and Benefits

- Suitable for roofs with a minimum pitch of 22.5°
- Free ventilation area of 9,450mm².
- Sized to replace one slate to provide a continuous visual appearance along the roof when viewed at all levels
- Shaped to manage and channel rainwater back down onto the roof tiles and away from the vent opening
- Provides a 110mm duct connection with the optional RTV-ADIS duct adapter
- 4mm spaced external grille to prevent rainwater ingress and keep out large insects, vermin and debris
- Lightweight and easy to handle

Relevant Standards

- BS EN 490:2011 Concrete roofing tiles and fittings for roof covering and wall cladding - product specifications (+A1:2017)
- BS 5250: 2021 Management of moisture in buildings – Code of practice
- BS 5534:2014 Slating and tiling for pitched roofs and vertical cladding – code of practice (+A2:2018)
- Manufactured to BS EN ISO 9001:2015 and BS EN ISO 14001:2015
- Complies with all relevant sections of the Building Regulations 2010
- Satisfies all relevant NHBC requirements

Compatibility

Natural or Synthetic slates from all major manufacturers in smaller sizes such as:

- 400 x 250mm
- 400 x 225mm
- 400 x 200mm
- 350 x 250mm
- 350 x 200mm
- 300 x 200mm

Material and Colour Choice

- Injection moulded Polypropylene with textured finish
- Available in Black

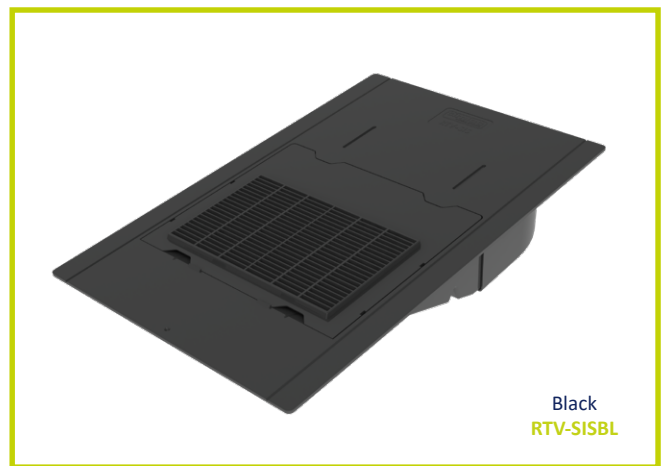
Scan to view the full product page on the Timloc website



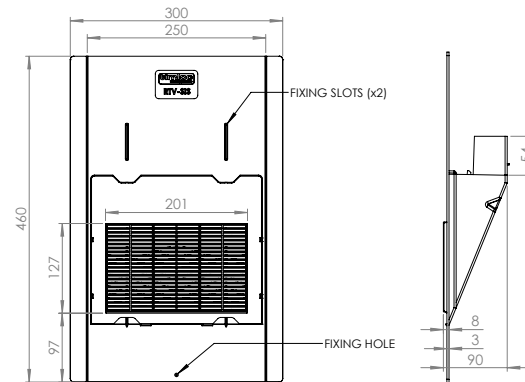
Product Codes

Product Description	Colour	Weight	Box Quantity	Product Code	Pack Quantity	Pack Code	Pallet Quantity
Small Inline Slate Vent	Black	0.64kg	1	RTV-SISBL	5	RTVMULTI-SISBL	120

NB. RTV-SISBL available in single, pack or pallet quantities. For pack quantities, 5 Small Inline Slate vent assemblies are packaged in one large box.



Product Dimensions



Compatible Accessories

- Full datasheets available for all accessories

Description	Product Code	Product Image
110mm Flexi-Pipe to aid connection to ventilation duct or soil vent pipe	RTV-KIT1	
Inline Slate adapter to attach the roof tile vent to 110mm ductwork	RTV-ADIS	
Multi adapter (RTV-ADMULTI) to aid connection to 100/110/125/150mm duct sizes	RTV-ADMULTI	
RTV-KIT1 and RTV-ADIS available as one kit	RTV-KIT4	

Airflow Test Data

RTV-SIS (100mm duct)	
Flow Rate l/s	Static pressure difference Pa
10	2
20	8
30	19
40	34

INVENTIVE

Roof ventilation solutions

RTV-HS | Hooded Slate Vent

Universal Hooded Slate Vent to enable ventilation directly into a roof space or connect to a ducted ventilation system

Uses

- On roofs with Natural or Synthetic Slates
- Enables ventilation directly into a roof space
- Can also be connected to a ducted ventilation system inside the building

Features and Benefits

- Suitable for roofs with a minimum pitch of 22.5°
- Max free ventilation area of 22,000mm²
- Sized to replace one slate to provide a continuous visual appearance along the roof when viewed at all levels
- The flat base of the vent means there is no need to cut roofing battens unless using the vent with a ducted system
- Shaped to manage and channel rainwater back down onto the roof tiles and away from the vent opening
- Can be connected to ventilation duct or soil vent pipe of various sizes with the optional RTV-ADHS duct adapter
- 4mm spaced external grille to prevent rainwater ingress and keep out large insects, vermin and debris
- Lightweight and easy to handle

Relevant Standards

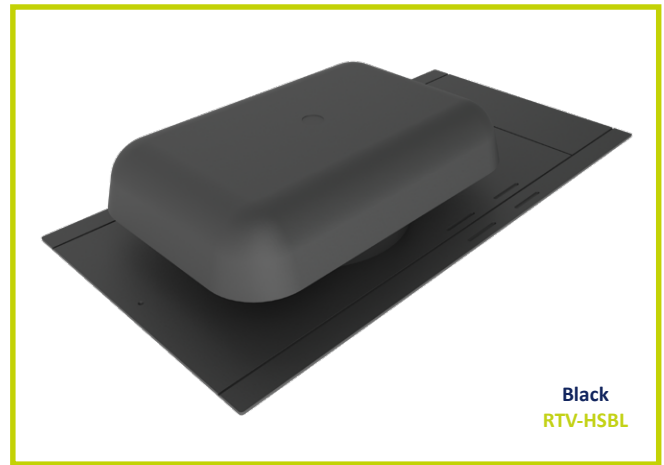
- BS EN 490:2011 Concrete roofing tiles and fittings for roof covering and wall cladding - product specifications (+A1:2017)
- BS 5250: 2021 Management of moisture in buildings – Code of practice
- BS 5534:2014 Slating and tiling for pitched roofs and vertical cladding – code of practice (+A2:2018)
- Manufactured to BS EN ISO 9001:2015 and BS EN ISO 14001:2015
- Complies with all relevant sections of the Building Regulations 2010
- Satisfies all relevant NHBC requirements

Compatibility

Natural or Synthetic slates in sizes 600mm x 300mm or 500mm x 250mm from all major manufacturers.

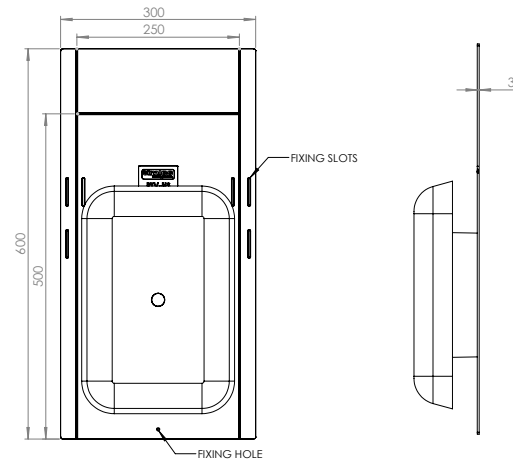
Material and Colour Choice

- Top - UV stabilised coloured injection moulded Polypropylene
- Available in Black
- Base – Black injection moulded Polypropylene



Black
RTV-HSBL

Product Dimensions



Compatible Accessories

- Full datasheets available for all accessories

Description	Product Code	Product Image
110mm Flexi-Pipe to aid connection to ventilation duct or soil vent pipe	RTV-KIT1	
Hooded Slate Adapter to aid connection to 110/125/150/170mm duct sizes	RTV-ADHS	
Multi adapter (RTV-ADMULTI) to aid connection to 100/110/125/150mm duct sizes	RTV-ADMULTI	
RTV-KIT1 and RTV-ADIS available as one kit	RTV-KIT4	

Airflow Test Data

Flow Rate l/s	RTV-HS (100mm duct)	RTV-HS (125mm duct)
	Static pressure difference Pa	
15	1	1
30	2	3
45	4	8
60	7	13
75	11	20
90	15	29

Product Codes

Product Description	Colour	Weight	Box Quantity	Product Code	Pack Quantity	Pack Code	Pallet Quantity
Hooded Slate Vent	Black	1.1kg	1	RTV-HSBL	4	RTVMULTI-HSBL	68

NB. RTV-HSBL available in single, pack or pallet quantities. For pack quantities, 4 Hooded Slate vent assemblies are packaged in one large box.

Scan to view the full product page on the Timloc website



Roof ventilation solutions

4001 | Universal Hooded Slate Vent

Universal Hooded Slate Vent to enable ventilation directly into a roof space or connect to a ducted ventilation system

Uses

- For replacement of one normal roof slate to provide a ventilator
- Ventilating a roof space at low level or high level
- Connection to mechanical extraction from kitchen/bathrooms
- Ventilation outlet for soil vent pipe

Features and Benefits

- Suitable for roofs with a minimum pitch of 22.5°
- Free ventilation area of 10,000mm²
- Suits slate sizes 600mm x 300mm or 500mm x 250mm
- Provides a 110mm duct connection with the optional 4101 pipe adapter kit
- Lightweight and easy to handle
- Inconspicuous low hood protects the internal grille from rainwater

Relevant Standards

- BS EN 490:2011 Concrete roofing tiles and fittings for roof covering and wall cladding - product specifications (+A1:2017)
- BS 5250: 2021 Management of moisture in buildings – Code of practice
- BS 5534:2014 Slating and tiling for pitched roofs and vertical cladding – code of practice (+A2:2018)
- Manufactured to BS EN ISO 9001:2015 and BS EN ISO 14001:2015
- Complies with all relevant sections of the Building Regulations 2010
- Satisfies all relevant NHBC requirements

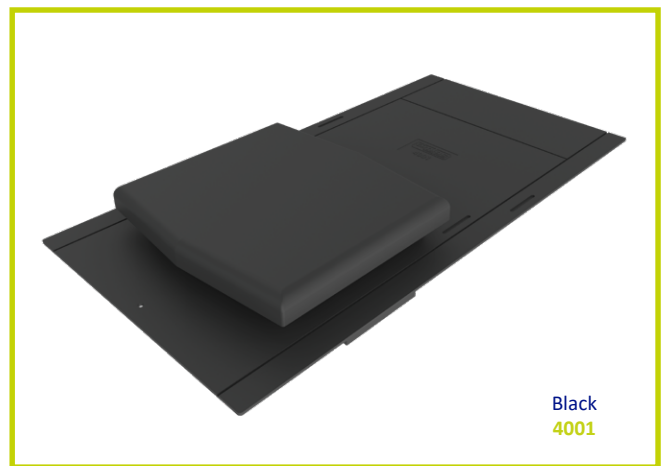
Compatibility

Natural or Synthetic slates in sizes 600mm x 300mm or 500mm x 250mm from all major manufacturers.

Material and Colour Choice

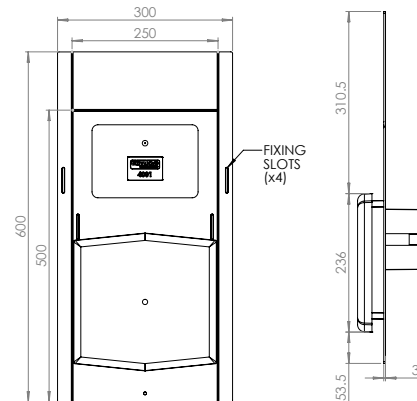
- Injection moulded Polypropylene
- Available in Black

Scan to view the full product page on the Timloc website



Black
4001

Product Dimensions



Compatible Accessories

- Full datasheets available for all accessories

Description	Product Code	Product Image
110mm Flexi-Pipe to aid connection to ventilation duct or soil vent pipe	RTV-KIT1	
Pipe Adapter Kit to aid connection to 110mm soil vent pipe or mechanical extractor	4101	
Multi adapter (RTV-ADMULTI) to aid connection to 100/110/125/150mm duct sizes	RTV-ADMULTI	

Airflow Test Data

4001 (100mm duct)	
Flow Rate l/s	Static pressure difference Pa
10	3
20	10
30	21
40	37

Product Codes

Product Description	Colour	Weight	Box Quantity	Product Code	Pallet Quantity
Universal Hooded Slate Vent	Black	0.8kg	5	4001	120
Pipe Adapter Kit	Black	0.5kg	1	4101	N/A
Pipe Adapter Only	Black	0.15kg	1	4102	N/A
Flexible PVC Pipe Only	White	0.3kg	1	4103	N/A

Roof ventilation solutions

110mm Flexi-Pipe Kits

110mm Flexi-Pipe kits for connection to ventilation duct or soil vent pipe

Uses

- To connect Timloc Roof Vents to 110mm ventilation duct or soil vent pipe

Features and Benefits

- Provides a precise fit to internal 110mm duct or soil vent pipe
- Flexible to bend into position during installation
- Tough to avoid tearing or damage and maintain its cross-sectional shape
- 112mm outside diameter fits directly to Timloc Tile Vent spigots
- Compatible with flexible, semi-rigid and rigid duct for further connection to a ventilation system
- Can be secured with supplied adjustable screw clamp, zip ties or glued/screwed

Components Supplied in Each Kit

- RTV-KIT1 contains 1x Flexi-Pipe and 1x Screw Clamp (compatible with: RTV-MC / RTV-SP)
- RTV-KIT2 contains 1x Flexi-Pipe, 1x RTV-ADS Standard Adapter and 1x Screw Clamp (compatible with: RTV-C / RTV-DP / RTV-DR / RTV-TE / RTV-FE / RTV-NP)
- RTV-KIT3 contains 1x Flexi-Pipe, 1x RTV-ADP Plain Adapter and 1x Screw Clamp (compatible with: RTV-P / RTV-IP / RTV-SLIP / RTV-LPP)
- RTV-KIT4 contains 1x Flexi-pipe, 1x RTV-ADIS Inline Slate Vent Adapter and 1x Screw Clamp (compatible with: RTV-IS)

Relevant Standards

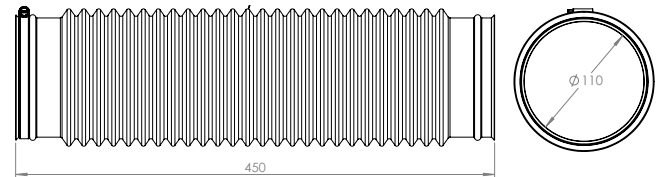
- BS 5250: 2021 Management of moisture in buildings – Code of practice
- Manufactured to BS EN ISO 9001:2015 and BS EN ISO 14001:2015
- Complies with all relevant Building Regulations 2010
- Satisfies all NHBC requirements

Material and Colour

- Blow moulded Polypropylene
- Available in Black only



Product Dimensions



Compatible Accessories

- Full datasheets available for all accessories

Description	Product Code	Product Image
Multi adapter (RTV-ADMULTI) to aid connection to 100/110/125/150mm duct sizes	RTV-ADMULTI	

Product Codes

Description	Colour	Weight	Qty	Product Code
Flexi-Pipe + Clamp	Black	0.22kg	1	RTV-KIT1
Flexi-Pipe + RTV-ADS + Clamp	Black	0.35kg	1	RTV-KIT2
Flexi-Pipe + RTV-ADP + Clamp	Black	0.35kg	1	RTV-KIT3
Flexi-Pipe + RTV-ADIS + Clamp	Black	0.46kg	1	RTV-KIT4

Scan to view the full product page on the Timloc website



Multi Stepped Duct Adapter

Duct adapter for converting to different size ductwork during installation

Uses

- To connect Timloc Roof Tile Vents to different sizes of ventilation duct

Features and Benefits

- Provides a precise fit to 110mm duct or soil vent pipe
- Trim along the indented edges to configure the duct size
- Provides a precise fit to 100/110/125/150mm duct
- 110mm outside diameter fits directly to Timloc Tile Vent spigots
- Compatible with flexible, semi-rigid and rigid duct
- Can be secured with adjustable screw clamps, zip ties or glued/screwed

Relevant Standards

- BS 5250: 2021 Management of moisture in buildings – Code of practice
- Manufactured to BS EN ISO 9001:2015 and BS EN ISO 14001:2015
- Complies with all relevant Building Regulations 2010
- Satisfies all NHBC requirements

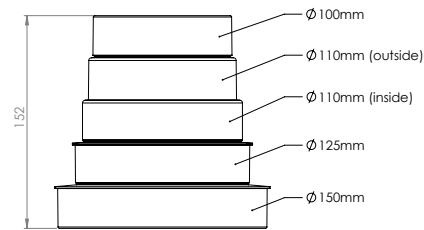
Material and Colour

- Injection moulded Polypropylene
- Available in Black only

Scan to view the full product page on the Timloc website






Product Dimensions



Compatible Accessories

- Full datasheets available for all accessories

Description	Product Code	Product Image
110mm Flexi-Pipe to aid connection to ventilation duct or soil vent pipe	RTV-KIT1	
Plain adapter to attach the roof tile vent to 110mm ductwork	RTV-ADP	
Standard adapter to attach the roof tile vent to 110mm ductwork	RTV-ADS	

Product Codes

Description	Colour	Weight	Qty	Product Code
Multi Stepped Duct Adapter	Black	0.22kg	10	RTV-ADMULTI

RTV-ADHS | Hooded Slate Vent Adapter

Stepped duct adapter for the Timloc Hooded Slate Vent

Uses

- To provide Timloc Hooded Slate Vents with a 110/125/150/170mm ventilation duct or soil vent pipe connection

Features and Benefits

- Compatible with the Timloc Hooded Slate Vent RTV-HS
- Simply click into position to secure the adapter to the tile vent
- The joint between the adapter and the slate vent must be fully sealed with silicon sealant or a similar watertight adhesive.
- Provides a precise fit to 110/125/150/170mm ventilation duct or soil vent pipe
- Simply cut along the indented line at your chosen duct size. No cutting is required for 110mm size.
- Where required the roof battens may need to be trimmed to allow the adapter to pass through the roof surface into the property

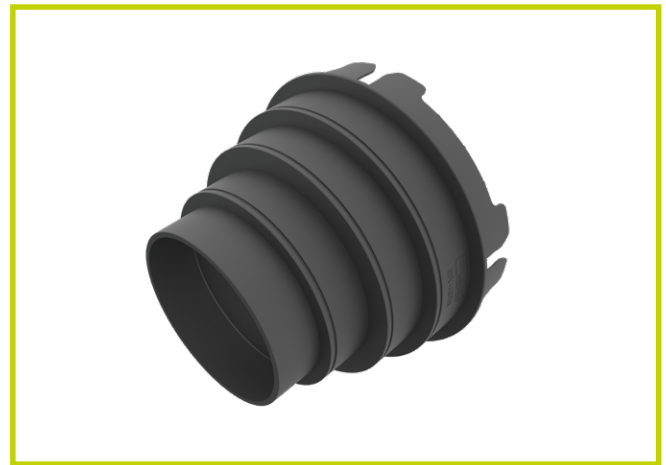
Relevant Standards

- BS 5250: 2021 Management of moisture in buildings – Code of practice
- Manufactured to BS EN ISO 9001:2015 and BS EN ISO 14001:2015
- Complies with all relevant Building Regulations 2010
- Satisfies all NHBC requirements

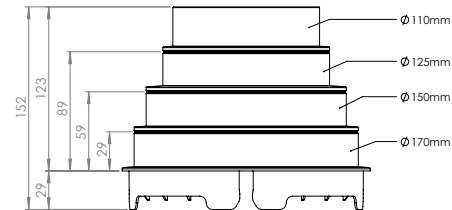
Material and Colour

- Injection moulded Polypropylene
- Available in Black only

Scan to view the full product page on the Timloc website



Product Dimensions



Compatible Accessories

- Full datasheets available for all accessories

Description	Product Code	Product Image
Multi adapter (RTV-ADMULTI) to aid connection to 100/110/125/150mm duct sizes	RTV-ADMULTI	
110mm Flexi-Pipe to aid connection to ventilation duct or soil vent pipe	RTV-KIT1	

Product Codes

Description	Colour	Weight	Qty	Product Code
Hooded Slate Vent Adapter	Black	0.22kg	10	RTV-ADHS

RTV-ADS | Standard Tile Vent Adapter

Duct adapter for Timloc Large Format Inline Roof Tile Vents



Uses

- To provide Timloc Roof Tile Vents with a 110mm duct or soil vent pipe connection

Features and Benefits

- Compatible with all Timloc Large Format Inline Roof Tile Vents RTV-C / RTV-DP / RTV-DR / RTV-TE / RTV-FE / RTV-NP
- The adapter reduces the maximum free vent are of the system from 10,000mm² to 8,600mm²
- Simply click into position to secure the adapter to the base of the tile vent
- Provides a precise fit to 110mm duct or Soil Vent Pipe
- Duct can be secured to the adapter with adjustable screw clamps, zip ties or glued/screwed

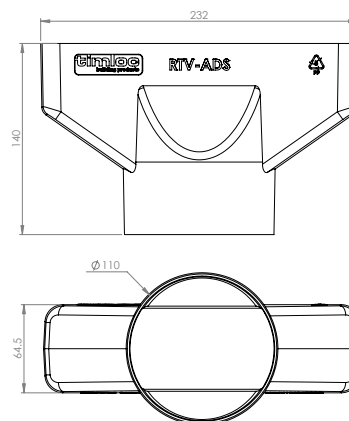
Relevant Standards

- BS 5250: 2021 Management of moisture in buildings – Code of practice
- Manufactured to BS EN ISO 9001:2015 and BS EN ISO 14001:2015
- Complies with all relevant Building Regulations 2010
- Satisfies all NHBC requirements

Material and Colour

- Injection moulded Polypropylene
- Available in Black only

Product Dimensions



Compatible Accessories

- Full datasheets available for all accessories

Description	Product Code	Product Image
Multi adapter (RTV-ADMULTI) to aid connection to 100/110/125/150mm duct sizes	RTV-ADMULTI	
110mm Flexi-Pipe to aid connection to ventilation duct or soil vent pipe	RTV-KIT1	

Product Codes

Description	Colour	Weight	Qty	Product Code
Standard Tile Vent Adapter	Black	0.13kg	12	RTV-ADS

Scan to view the full product page on the Timloc website



RTV-ADP | Plain Tile Vent Adapter

Duct adapter for Timloc Plain and Interlocking Plain Roof Tile Vents

Uses

- To provide Timloc Roof Tile Vents with a 110mm duct or soil vent pipe connection

Features and Benefits

- Compatible with Timloc Plain Roof Tile Vents RTV-P / RTV-IP / RTV-LPP / RTV-SLIP without reducing the free vent area of the system.
- Simply click into position to secure the adapter to base of the tile vent
- Provides a precise fit to 110mm duct or Soil Vent Pipe
- Duct can be secured to the adapter with adjustable screw clamps, zip ties or glued/screwed.

Relevant Standards

- BS 5250: 2021 Management of moisture in buildings – Code of practice
- Manufactured to BS EN ISO 9001:2015 and BS EN ISO 14001:2015
- Complies with all relevant Building Regulations 2010
- Satisfies all NHBC requirements

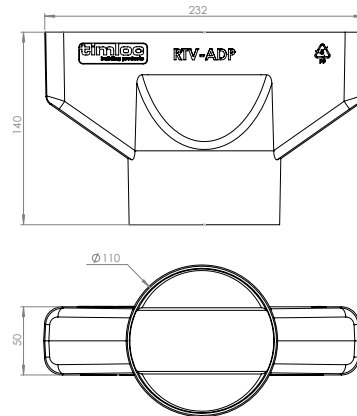
Material and Colour

- Injection moulded Polypropylene
- Available in Black only

Scan to view the full product page on the Timloc website



Product Dimensions



Compatible Accessories

- Full datasheets available for all accessories

Description	Product Code	Product Image
Multi adapter (RTV-ADMULTI) to aid connection to 100/110/125/150mm duct sizes	RTV-ADMULTI	
110mm Flexi-Pipe to aid connection to ventilation duct or soil vent pipe	RTV-KIT1	

Product Codes

Description	Colour	Weight	Qty	Product Code
Plain Tile Vent Adapter	Black	0.13kg	12	RTV-ADP

RTV-ADIS | Inline Slate Vent Adapter

110mm duct adapter for the Timloc Inline Slate Vent

Uses

- To provide Timloc Inline Slate Vents with a 110mm duct or soil vent pipe connection

Features and Benefits

- Compatible with the Timloc Inline Slate Vent RTV-IS
- Simply click into position to secure the adapter to the spigot of the tile vent
- Provides a precise fit to 110mm duct or Soil Vent Pipe
- Adapter sits below the roof batten to provide a simple, neat installation

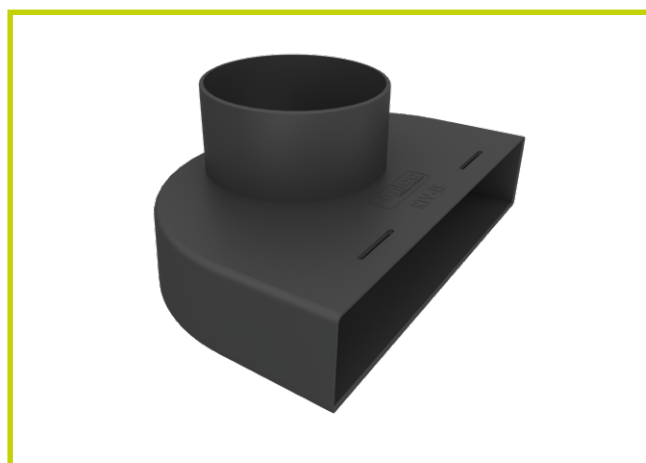
Relevant Standards

- BS 5250: 2021 Management of moisture in buildings – Code of practice
- Manufactured to BS EN ISO 9001:2015 and BS EN ISO 14001:2015
- Complies with all relevant Building Regulations 2010
- Satisfies all NHBC requirements

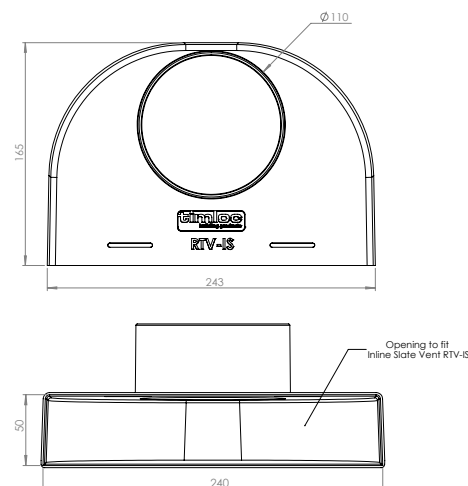
Material and Colour

- Injection moulded Polypropylene
- Available in Black only

Scan to view the full product page on the Timloc website



Product Dimensions



Compatible Accessories

- Full datasheets available for all accessories

Description	Product Code	Product Image
Multi adapter (RTV-ADMULTI) to aid connection to 100/110/125/150mm duct sizes	RTV-ADMULTI	
110mm Flexi-Pipe to aid connection to ventilation duct or soil vent pipe	RTV-KIT1	

Product Codes

Description	Colour	Weight	Qty	Product Code
Inline Slate Vent Adapter	Black	0.24kg	10	RTV-ADIS

THROUGH-WALL VENTILATION

Product	Page No.
Cavity Sleeves	151
Internal Grilles and Airbrick Cowls	152
Aero Core Anti-Draught Ventilators	154
Technical Information & Installation Advice	155

SCAN
TO VIEW



PRODUCT
DATASHEETS

AVAILABLE



Cavity Sleeves

Tough, flexible ventilators for external walls

Use

- To provide ventilation through external walls to the building interior

Features and Benefits

- Unrestricted free airflow
- Lightweight and easy to handle
- Durable and totally resistant to decay

Quality

- Satisfies all NHBC requirements
- Manufactured to BS EN ISO 9001 and BS EN ISO 14001
- Complies with all relevant Building Regulations
- Meets all relevant British Standards

Material and Colour Choice

- Injection moulded in polypropylene
- All accessories are available in black only

Products in the System

1202-1

- Suits a single 9" x 3" Timloc airbrick and provides a maximum equivalent area of 6170mm².

1202-2

- Suits a stack of two interlocked Timloc airbricks 9" x 6" and provides a maximum equivalent area of 12300mm².

1237

- Fitted to rear of 1202/1 to give maximum extension of 365mm.

1236

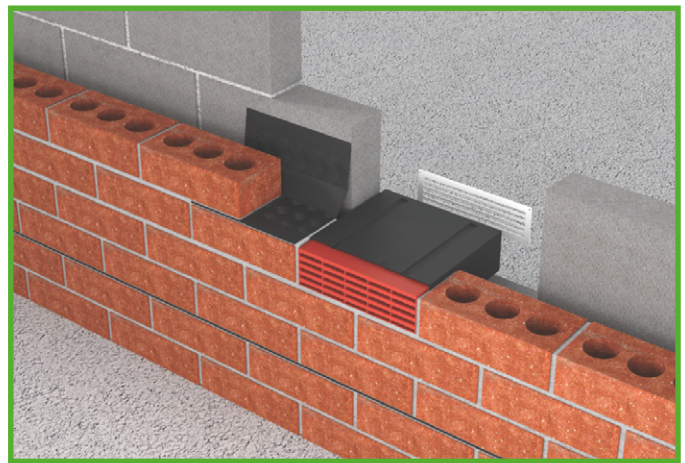
- Fitted to rear of 1202/2 to give maximum extension of 365mm.

1238

- Baffle to offer draught reduction inline with fitment to 1202/1 & /2.

Installation Advice

- Always use in conjunction with a Timloc airbrick
- When ventilating through an external wall to a building interior, ensure the cavity sleeve and airbrick are positioned above the ground floor dpc level. The exact position will depend on what conveniently suits the interior room. Installation of the cavity sleeve and airbrick at high level in the room will help reduce the effect of draughts
- When fitted with a Timloc airbrick, the cavity sleeve suits walls up to 275mm overall thickness. If thicker walls are present, two cavity sleeves may be joined, end to end, and then trimmed to the required length and telescopic extension available
- It is strongly recommended that a section of horizontal cavity tray (Timloc Inter-loc 4 and 2 wall weeps) is positioned above the airbrick and cavity sleeve to prevent rainwater tracking across the top of the cavity sleeve
- The number of cavity sleeves and airbricks required depends on the volume of free airflow demanded by the situation
- For background ventilation into a habitable room 8000mm² of free area is required. i.e. two 9" x 3" cavity sleeves and airbricks, or a single 9" x 6" cavity sleeve and two airbricks stacked one above the other
- If ventilating a room containing a heat producing appliance the volume of free airflow will depend on the type and size of the appliance. Consult the appliance manufacturers technical information, and then provide the appropriate number and size of cavity sleeves and airbricks. Remember that each 9" x 3" airbrick provides max. 6170mm² equivalent area



How to Order

- Assess background ventilation required for the application and determine which sleeve is appropriate
- Remember to order the correct number of airbricks for each cavity sleeve and possible telescopic extension sleeves. Optional draft reducing baffle is available (2 x per 9" x 6")

Bill of Quantity

F30 Accessories/sundry items for brick/block/stone walling

Clause

160 AIR BRICK

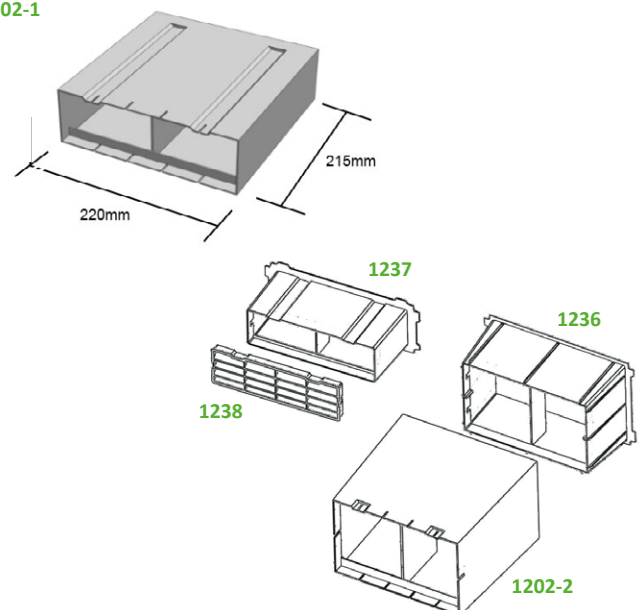
- To BS493, Class 1, built in as the work proceeds.
- Manufacturer: Timloc Building Products, Timloc House, Ozone Park, Howden, East Yorkshire, DN14 7SD. T: 01405 765567 W: www.timloc.co.uk
- Reference:
 - 1202/1 Cavity Sleeve, single brick.
 - 1202/2 Cavity Sleeve, double brick.
- Design: Rectangular
- Material: Thermoplastic
- Colour: Black

Product Codes

Description	To Suit	Box Qty	Product Code
9 x 3 cavity sleeve	1 airbrick	20	1202/1
9 x 6 cavity sleeve	2 airbricks stacked	1	1202/2
9 x 3 telescopic extension	+ 90mm	1	1237
9 x 6 telescopic extension	+ 90mm	1	1236
9 x 3 baffle	1 airbrick	1	1238

Product Codes

1202-1



Scan to view the full product page on the Timloc website



Internal Grilles & Airbrick Cows

For sustaining airflow and reducing draughts

Use

- To cover the inner opening on the cavity sleeve and provide a neater appearance while still maintaining a free flow of air
- To provide an external cowl over the airbrick to help reduce draughts caused by wind blasts

Features and Benefits

- Aesthetically pleasing
- Simple screw fixing
- Excellent airflow properties
- Durable and totally resistant to decay

Quality

- Satisfies all NHBC requirements
- Manufactured to BS EN ISO 9001 and BS EN ISO 14001
- Complies with all relevant Building Regulations
- Meets all relevant British Standards

Material and Colour Choice

Plastic grilles

- Manufactured by injection moulding in ABS/HIPS
- Available in white only

Metal grilles

- Manufactured in high quality pressed aluminium
- Grilles are available in three types of finish, plain aluminium, brass anodised and polished brass

External cowls

- Manufactured by injection moulding in polypropylene
- Cowls are available in white, brown and terracotta

Products in the System

Timloc offer a complete range of high quality plastic grilles which cover the internal opening of the cavity sleeve and provide a neat appearance

Louvre grilles

A permanently open vent with no flyscreen or closing method but with visible airflow marking to comply with the requirements of BS5440 Part 2 2009 : BS EN 13141-1 : 2004.

Louvre grilles with flyscreen

A permanently open vent with a fixed flyscreen but no airflow indication.

Adjustable (hit and miss) grilles

Can be open or closed with an integral flyscreen but no airflow indication.



Installation Advice

- Internal grilles should be positioned over the internal opening of the cavity sleeve and fixed to the wall using screws and wall plugs
- External cowls are positioned over the face of the airbrick and fixed to the wall using screws and wall plugs. The opening of the cowl should face down towards the ground
- Never block or restrict the flow of air through these ventilators. The louvre grilles have no insect screen fitted - in order to comply with British Gas requirements
- Use open louvre grilles when ventilating a gas or heat producing appliance - never use hit & miss grilles in such situations

How to Order

- State the grille or cowl size, and whether louvre, flyscreen or hit & miss grilles are required

Bill of Quantity

Cowl range

F30 Accessories/sundry items for brick/block/stone walling

Clause

171 VENTILATION DUCTS

- To BS493, Class 1, built in as the work proceeds.
- Manufacturer: Timloc Building Products, Timloc House, Ozone Park, Howden, East Yorkshire, DN14 7SD. T: 01405 765567 W: www.timloc.co.uk
- Reference: ABC Cowl Range
- Use: To provide an external cowl over the airbrick to help reduce draughts caused by wind blasts.

Plastic & metal wall grilles 1200 range

U90 General Ventilation - Domestic

INTERNAL WALL VENTILATION

- Manufacturer: Timloc Building Products, Timloc House, Ozone Park, Howden, East Yorkshire, DN14 7SD. T: 01405 765567, W: www.timloc.co.uk
- Reference: Reference: Plastic & Metal wall grilles 1200 range
- Use: To cover the inner opening on the cavity sleeve and provide an aesthetically acceptable appearance, while still maintaining a free flow of air. Available in a range of airflow sizes with both c

Product Codes

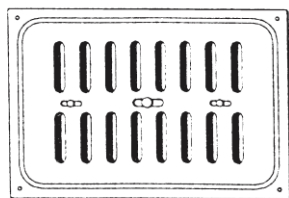
Equivalent Area	Equivalent Area (Flyscreen)	Product Code
4100mm ²	2350mm ²	1218 (6 x 3 louvred)
7600mm ²	3750mm ²	1207 (9 x 3 louvred)
11300mm ²	7150mm ²	1211 (9 x 6 louvred)
16500mm ²	8190mm ²	1212 (9 x 9 louvred)

Scan to view the full product page on the Timloc website

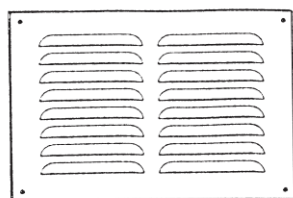


Internal Grilles & Airbrick Cowl

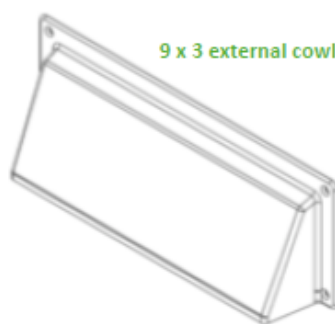
For sustaining airflow and reducing draughts



Metal hit and miss vent



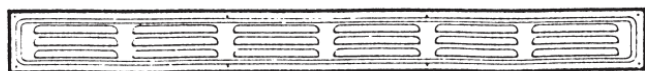
Metal louvre vent



9 x 3 external cowl



9 x 6 external cowl



Metal return air grille

Product Codes

Internal Plastic Grilles

Description	Colour	Fixing Hole Dimensions	Overall Dimensions	Equivalent Area	Product Code
6 x 3 louvre 'mini vent'	White	148mm x 67mm	166mm x 85mm	4100mm ²	1218W
9 x 3 louvre vent	White	242mm x 86mm	260mm x 194mm	7600mm ²	1207W
9 x 6 louvre vent	White	242mm x 152mm	260mm x 170mm	11300mm ²	1211W
9 x 9 louvre vent	White	242mm x 217mm	260mm x 235mm	16500mm ²	1212W
6 x 3 louvre vent with flyscreen	White	148mm x 67mm	166mm x 85mm	2350mm ²	1218WF
9 x 3 louvre vent with flyscreen	White	242mm x 86mm	260mm x 104mm	3750mm ²	1207WF
9 x 6 louvre vent with flyscreen	White	242mm x 152mm	260mm x 170mm	7150mm ²	1211WF
9 x 9 louvre vent with flyscreen	White	242mm x 217mm	260mm x 235mm	8190mm ²	1212WF
6 x 3 hit & miss 'mini vent'	White	148mm x 67mm	166mm x 85mm	2350mm ²	1219W
9 x 3 hit & miss louvre vent	White	242mm x 86mm	260mm x 104mm	3750mm ²	1208W
9 x 6 hit & miss louvre vent	White	242mm x 152mm	260mm x 170mm	7150mm ²	1209W
9 x 9 hit & miss louvre vent	White	242mm x 217mm	260mm x 235mm	8190mm ²	1210W

Internal Metal Grilles

Description	Colour	Fixing Hole Dimensions	Overall Dimensions	Equivalent Area	Product Code
9 x 3 hit & miss vent	Plain aluminium	230mm x 77mm	242mm x 89mm	3741mm ²	1220A
9 x 3 hit & miss vent	Brass anodised	230mm x 77mm	242mm x 89mm	3741mm ²	1220BA
9 x 3 hit & miss vent	Polished brass	230mm x 77mm	242mm x 89mm	3741mm ²	1220PB
9 x 6 hit & miss vent	Plain aluminium	230mm x 153mm	242mm x 165mm	6452mm ²	1221A
9 x 6 hit & miss vent	Brass anodised	230mm x 153mm	242mm x 165mm	6452mm ²	1221BA
9 x 6 hit & miss vent	Polished brass	230mm x 153mm	242mm x 165mm	6452mm ²	1221PB
9 x 9 hit & miss vent	Plain aluminium	230mm x 230mm	242mm x 242mm	11250mm ²	1222A
9 x 9 hit & miss vent	Brass anodised	230mm x 230mm	242mm x 242mm	11250mm ²	1222BA
9 x 9 hit & miss vent	Polished brass	230mm x 230mm	242mm x 242mm	11250mm ²	1222PB
9 x 3 louvre vent	Plain aluminium	230mm x 77mm	242mm x 89mm	3973mm ²	1223A
9 x 3 louvre vent	Brass anodised	230mm x 77mm	242mm x 89mm	3973mm ²	1223BA
9 x 3 louvre vent	Polished brass	230mm x 77mm	242mm x 89mm	3973mm ²	1223PB
9 x 6 louvre vent	Plain aluminium	230mm x 153mm	242mm x 165mm	7946mm ²	1224A
9 x 6 louvre vent	Brass anodised	230mm x 153mm	242mm x 165mm	7946mm ²	1224BA
9 x 6 louvre vent	Polished brass	230mm x 153mm	242mm x 165mm	7946mm ²	1224PB
9 x 9 louvre vent	Plain aluminium	230mm x 230mm	242mm x 242mm	12770mm ²	1225A
9 x 9 louvre vent	Brass anodised	230mm x 230mm	242mm x 242mm	12770mm ²	1225BA
9 x 9 louvre vent	Polished brass	230mm x 230mm	242mm x 242mm	12770mm ²	1225PB
25.2 x 2 return air grille	Plain aluminium	636mm x 48mm	648mm x 60mm	9774mm ²	1226A
25.2 x 2 return air grille	Brass anodised	636mm x 48mm	648mm x 60mm	9774mm ²	1226BA

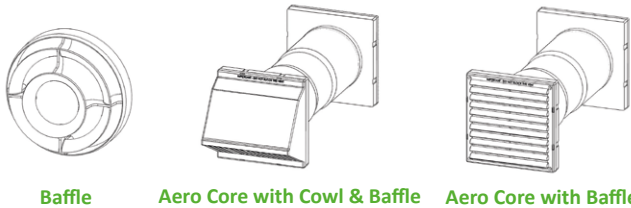
External Cowls

Description	Colour	Fixing Hole Dimensions	Overall Dimensions	Equivalent Area	Product Code
9 x 3 external cowl	Terracotta	237mm x 78mm	255mm x 96mm	8700mm ²	ABC93TE
9 x 3 external cowl	Brown	237mm x 78mm	255mm x 96mm	8700mm ²	ABC93BR
9 x 6 external cowl	Terracotta	237mm x 136mm	255mm x 154mm	16000mm ²	ABC96TE
9 x 6 external cowl	Brown	237mm x 136mm	255mm x 154mm	16000mm ²	ABC96BR
9 x 9 external cowl	Terracotta	256mm x 217mm	274mm x 235mm	23900mm ²	ABC99TE
9 x 9 external cowl	Brown	256mm x 217mm	274mm x 235mm	23900mm ²	ABC99BR

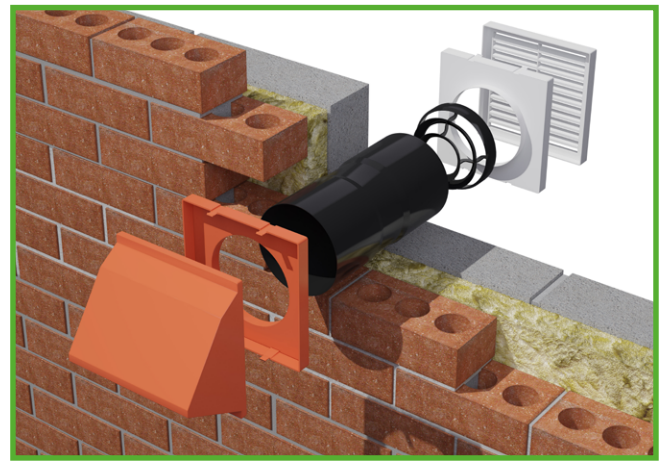
NB. Guidance in BS EN 13141-1 : 2004 indicates the "free area" of a background ventilator is typically 25% larger than its "equivalent area"

Aero Core Anti-Draught Ventilators

Combination ventilator sets for background venting and heat producing appliances



Baffle Aero Core with Cowl & Baffle Aero Core with Baffle



Use

- To provide ventilation for heat producing appliances
- To provide background room ventilation
- Individual ventilation sets can supply up to maximum appliance rated input of 24.8kW (84,600 Btu/h)
- Ideal solution for refurbishment, remedial work and new build

Features and Benefits

- Aesthetically pleasing and a simple to install modular system
- Excellent airflow properties
- Independently tested
- Reduction of draughts and light compared to basic through wall ventilation
- Cowl or grille version available with baffle
- Internal finish with open louvre grille

Quality

- Equivalent area tested to BS5440-2:2009
- Compliant with BS 5871-3:2005 & BS 493:1995
- Complies with Building Regulation Approved Documents F & J (2010 editions)
- Complies with 'The Scottish Building Standards' Technical handbooks
- Manufactured to BS EN ISO 9001 and BS EN ISO 14001
- Meets the requirements of British Gas
- Satisfies NHBC Standards

Material and Colour Choice

- UV stabilised cowls & grilles
- External grille/cowls in terracotta & brown
- Internal grilles are white as standard

Products in the System

5" Aero core vent - ACV7 (with baffle)

Provides an equivalent area of 8000mm² and suitable for venting appliances up to 23kW rated input.

5" Aero core vent with cowl - ACV7C (with baffle)

Provides an equivalent area of 8900mm² and suitable for venting appliances up to 24.8kW rated input.

5" Aero core vent high rise - ACV7HR

Provides an equivalent area of 5000mm² and suitable for venting appliances up to 17kW rated input.

Product Codes

Description	Colour	Equivalent Area	Size	Appliance Rated Input	Product Code
5" (127mm) aero core with baffle	Terracotta	8000mm ²	127mm (D) x 350mm	23kW (78,500Btu)	ACV7TE
5" (127mm) aero core with baffle	Brown	8000mm ²	127mm (D) x 350mm	23kW (78,500Btu)	ACV7BR
5" (127mm) aero core with cowl & baffle	Terracotta	8900mm ²	127mm (D) x 350mm	24.8kW (84,600Btu)	ACV7CTE
5" (127mm) aero core with cowl & baffle	Brown	8900mm ²	127mm (D) x 350mm	24.8kW (84,600Btu)	ACV7CBR
5" (127mm) aero core high rise	Terracotta	5000mm ²	127mm (D) x 350mm	17kW (58,000Btu)	ACV7HRTE

Installation Advice

- Core anti draught ventilators can be installed in new build, but benefit the installer most for use in existing walls
- To fit in existing cavity wall make hole through full cavity wall by using 127-130mm core drill ensuring a small incline towards the outer wall and remove brickwork debris to fit vent
- Large flanges around the external cowl and internal grille allow minor irregularities to be covered easily and adequate fixing. External cowl will push onto sleeve and can be silicone sealed to face or screw fixed

How to Order

- State the correct anti-draught ventilator for the heating appliance to be vented or background ventilation required
- State the required colour of external cowl and/or grille

Bill of Quantity

F30 Accessories/sundry items for brick/block/stone walling

Clause

171 VENTILATION DUCTS

- To BS493, Class 1, built in as the work proceeds.
- Manufacturer: Timloc Building Products, Timloc House, Ozone Park, Howden, East Yorkshire, DN14 7SD. T: 01405 765567, W: www.timloc.co.uk
- Reference: e.g. ACV7bu Timloc Aero 5" Core Vent in Brown 10,000mm² (suit appliance rated output max 27kW)
- Install across cavity, sloping away from inner leaf, bedding fully in mortar to seal cavity.



Scan to view the full product page on the Timloc website

Technical Information and Installation Advice

Through-Wall Ventilation

Through the wall ventilators provide passive ventilation through external walls into habitable rooms. It is important to differentiate between a ventilator which is required to provide general background ventilation and one which provides air into a room which contains a heat producing appliance such as a central heating boiler or gas fire.

- If the room contains a heat producing appliance the provision of constant and reliable ventilation is vitally important, extra and above to background ventilators. The anti draught ventilator products are strongly recommended for this application as they comply fully with legislation governing gas and heating appliances. The size and number of anti draught ventilator products required will be dictated by the requirements of the particular heating appliance and it is strongly recommended that advice is sought from the manufacturer
- General recommendations for the specification and use of through the wall ventilators are detailed below:
- Always check that the appropriate size and number of through the wall ventilators are used to suit the application
- Never fit just an airbrick. A cavity sleeve must always be fitted to the back of the airbrick to ensure that the air is transmitted effectively through the wall and into the room
- Hit and miss grilles may only be used for general background ventilation, they must **never** be used to ventilate any kind of gas or heating appliance
- Ventilators used to provide air for gas or heating appliances must be permanently open, there must be no facility to block or close the ventilator. Also, they must **not** contain any kind of fine mesh or insect screen
- Through the wall ventilators should always be fitted well above external ground level so as to ensure that rain and snow water cannot enter the ventilator
- It is recommended that a section of horizontal cavity tray is installed directly above the through the wall ventilator so as to prevent water from tracking across the cavity sleeve from the outer leaf to the inside of the building
- In order to help reduce the effect of draughts it is worth considering positioning the through the wall ventilator close to any heating appliance rather than at the opposite side of the room. Positioning the ventilator at high level

TOP HATS, GAS BARRIERS & DPC

Product	Page No.
Top Hats & Flexible Top Hats	157
1201 Top Hat	158
Radon Sump	159
Damp Proof Coursing Accessories	160
Gas Barrier & Damp Proof Systems & Accessories	161

SCAN
TO VIEW



**CATEGORY
GUIDE**

AVAILABLE



Top Hats & Flexible Top Hats

For sealing to a gas barrier and at the intersection of pipe projections

Use

- In areas outlined in BRE document 'Radon' guidance on protective measures in new dwellings
- When gas protection is required across the footprint of the building
- Crossing cavity wall constructions to maintain gas barrier integrity
- Forming internal perimeter trays to allow membranes continuity
- Collars for service pipe protrusions
- Following a risk assessment where the requirement is for a good gas protection measure against Radon, Co2, Methane and Hydrocarbon
- To be designed and installed in a continuous system around the whole building perimeter

Features and Benefits

- Preformed mouldings eliminate the need for site fabrication to prevent errors through poor workmanship
- Easy to handle, flexible, tough, durable and puncture resistant
- Can be used for multi-storey or high-loading applications – will not extrude under high loads up to the point of compression failure of wall
- Wide range of standard components with special tailor made accessories also available
- Fully itemised scheduling service

Quality

- Manufactured to BS EN ISO 9001 and BS EN ISO 14001
- Satisfies all NHBC requirements
- Meets BRE requirements
- Complies with Building Regulation Approved Documents C1 and C2
- Meets all relevant British Standards

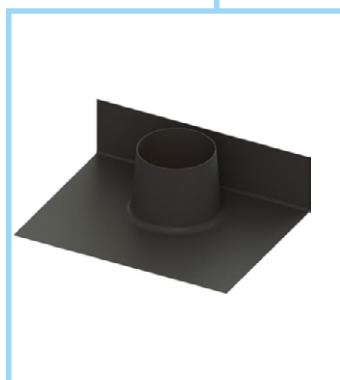
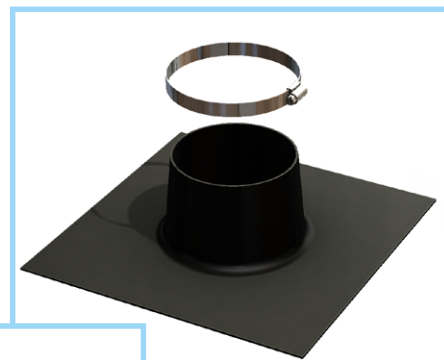
Material and Colour Choice

- Formed in 2mm medium density polyethylene and/or polypropylene
- Available in black only

Installation Advice

Units will require tape and seal - tape sold separately. Use GTAPE01 to make the seal between joint surfaces. Use GTAPE02 to seal upper surface to minimise lap lifting if used in concrete floors

Scan to view the full product page on the Timloc website



Products in the Range

Top hat pipe collars (TH055, TH082, TH110, TH135, TH160)

Top hat pipe collars are available in sizes from 55mm to 160mm. A standard range of preformed pipe sleeves that are designed to have sealing tape applied to the unit base to offer a unit for sealing to a gas barrier and at the intersection of pipe projections. Common applications are for soil / service pipes passing vertically via a gas barrier or membrane to maintain a continuous seal. Top hats are suitable for installation at ceiling level for pipe protrusions to assist in reducing air leakage. All jubilee clips are supplied separate to top hat units.

Jubilee clips size 5 for TH055

Jubilee clips size 6 for TH110

Jubilee clips size 7 for TH160

Flexible top hat (77110,77135)

The flexible top hat has been designed to be flexible enough to fit around difficult applications and is perfect for use in tight situations where a pipe is located close to a wall

Product Codes

Description	Product Code
Top hat pipe collar 55mm	TH055
Top hat pipe collar 82mm	TH082
Top hat pipe collar 110mm	TH110
Top hat pipe collar 135mm	TH135
Top hat pipe collar 160mm	TH160
Jubilee clips size 5, 6 or 7	JCLIP 5, 6 or 7
Flexible top hat pipe collar 110mm diameter	77110
Flexible top hat pipe collar 135mm diameter	77135
Gastite sealing tape 15m x 100mm	GTAPE01
Girth tape 75m x 50mm	GTAPE02

1201 Top Hat

Top hat collar for sealing telescopic underfloor vent

Use

- Top hat collar for sealing telescopic underfloor vent
- When gas protection is required
- Suitable for Radon, Hydrocarbon, Methane and CO2

Features and Benefits

- Preformed mouldings eliminate the need for site fabrication to prevent errors through poor workmanship
- Easy to handle, flexible, tough, durable and puncture resistant
- Manufactured to fit Timloc 1201, 1201XL & 1201XLPLUS

Quality

- Satisfies all NHBC requirements
- Manufactured to BS EN ISO 9001-2015
- Complies with all relevant Building Regulations
- Meets all relevant British Standard

Material and Colour Choice

- Manufactured from medium-density polyethylene (MDPE)
- Available in black only

Installation Advice

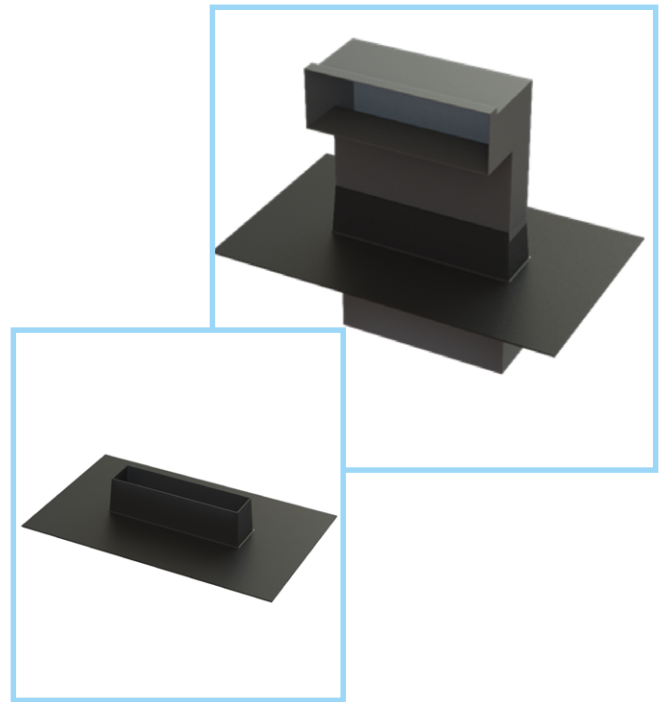
- Cut DPC / cavity trays to work around telescopic underfloor vent
- Separate top and bottom sections of 1201 telescopic vent and slot 1201 top hat over either half
- Position 1201 top hat to required position to sit over DPC / cavity tray
- Unit will require tape seal for gas barrier - Tape sold separately
- Use gastite G-Tape01 to make seal around full flat base surface
- Use girth tape G-tape02 to seal upstand to 1201 telescopic vent

Dimensions

- 425mm x 257mm x 60mm (H x W x D)

How To Order

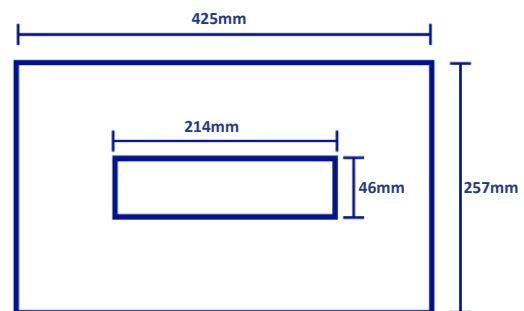
- Order as each
- State product code



Product Code

Description	Product Code
1201 top hat	77120
Gastite sealing tape 15m x 100mm	GTAPE01
Girth tape 75m x 50mm	GTAPE02

Product Dimensions



Scan to view the full product page on the Timloc website

Radon Sump

Prefabricated plastic sump for use where sub floor depressurisation is required

Use

- Where sub floor depressurisation is required under full radon protection.
- The sump is installed beneath the floor slab in non suspended floor applications and vented to atmosphere via a connecting 110mm drainage pipe to an external source and capped off with proprietary products i.e. air bricks & telescopic under floor vents or roof vents.

Features and Benefits

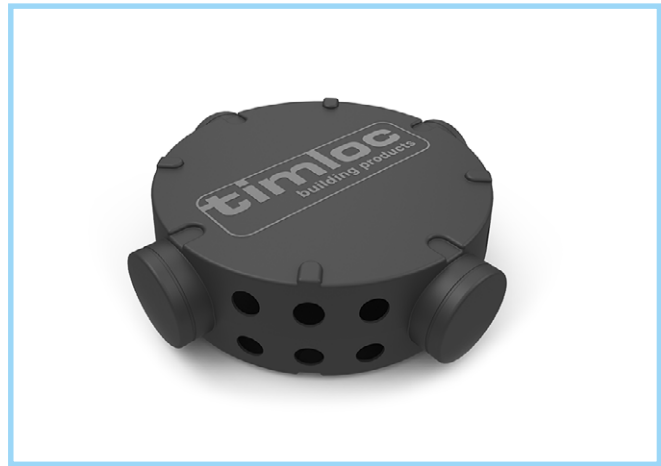
- Compatible with 110mm drainage pipes.
- Single piece moulding eliminates the need for on-site fabrication preventing errors through poor workmanship.
- Easy to handle and position.
- Tough, durable and puncture resistant.
- Spigot ends can be cut along the indented lines as required to provide extra pipe connections.
- Two or more sumps can be connected with pipework to provide more capacity for larger or more complex groundwork sites with multiple compartments.

Quality

- Satisfies all NHBC requirements
- Manufactured to BS EN ISO 9001 and BS EN ISO 14001
- Complies with all relevant Building Regulations
- Meets all relevant British Standards
- UK Design Registration Number 6185786

Material and Colour Choice

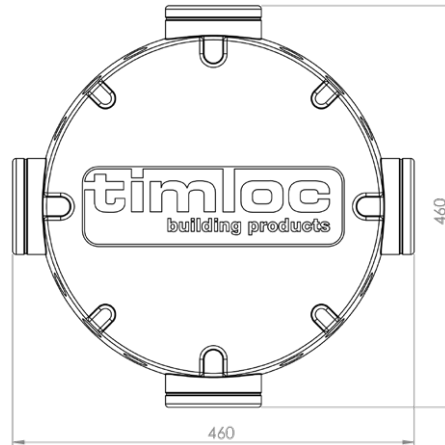
- Moulded in 3mm thick medium density polyethylene
- Available in black only



Product Codes

Description	Pack Quantity	Lead Time	Product Code
Radon sump	1	Next Working Day	RSUMP01

Product Dimensions

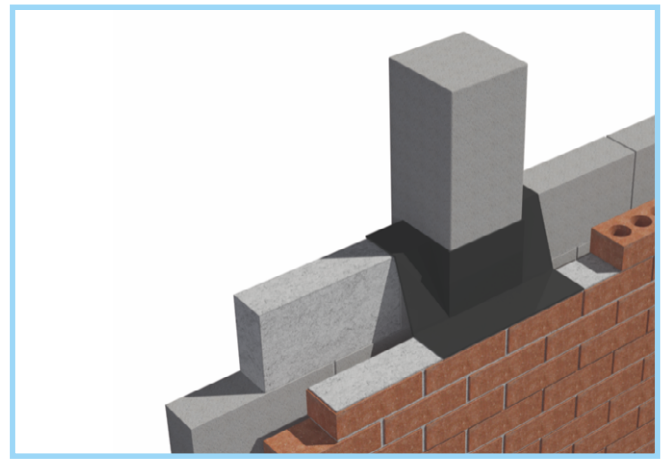
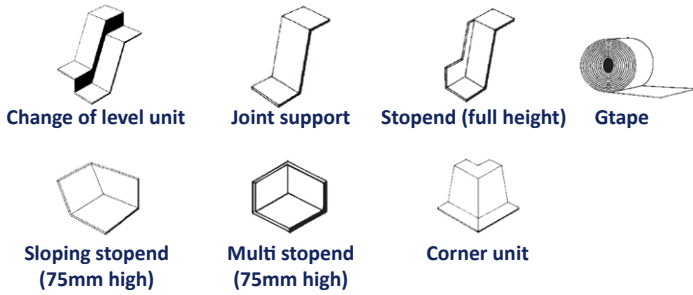


Scan to view the full product page on the Timloc website



Damp Proof Coursing Accessories

Products allowing a complete horizontal cavity tray system to be formed



Use

- Wherever DPC is used to form a horizontal cavity tray

Features and Benefits

- One piece seamless mouldings eliminate the need for site fabrication to prevent errors through poor workmanship
- Easy to handle, flexible, tough, durable and puncture resistant
- Can be used for multi-storey or high loading applications - will not extrude under loads up to the point of compressive failure of wall
- Wide range of standard components with special, tailor-made accessories also readily available

Quality

- Satisfies all NHBC requirements
- Manufactured to BS EN ISO 9001 and BS EN ISO 14001
- Complies with all relevant Building Regulations
- Meets all relevant British Standards

Material and Colour Choice

- Moulded in 2.0mm thick medium density polyethylene. They do not contain any pitch, tar or bitumen. Available in black only

Products in the System

Corner units

- For use where a cavity tray must turn the corner of a building

Change of level units

- For use where the cavity tray steps up or down along its run

Stopend units

- For sealing off the ends of the cavity tray at its start and finish

Jointing tape

- For sealing lapped joints in the DPC or for sealing the DPC on to the accessories

Joint supports

- For fitting below lapped joints in the DPC to provide support and allow the jointing tape to be sealed correctly

Installation Advice

- As with the DPC, accessories should always be bedded on to fresh mortar, never dry bedded. The masonry laid over the DPC should also be bedded on to fresh mortar so that the DPC is approximately half way through the thickness of the mortar joint
- DPC must be lapped on to the accessory by a minimum of 100mm
- All lapped joints must be fully sealed with jointing tape. It is essential that the jointing surfaces are clean and dry or the jointing tape will not seal correctly

How to Order

- State the wall construction, cavity width and the rise which is required across the cavity
- If you need a special, tailor-made accessory - please supply a dimensioned sketch detailing your requirements

Bill of Quantity

F30 Accessories/sundry items for brick/block/stone walling

Clause

380 | PREFORMED DPC/CAVITY TRAY JUNCTION CLOAKS/STOPENDS

- Manufacturer: Timloc Building Products, Timloc House, Ozone Park, Howden, East Yorkshire, DN14 7SD. T: 01405 765567 W: www.timloc.co.uk
- Type(s) and location(s): Preformed stopend units to be positioned at the start and finish of a run of cavity trays.
- Seal all laps with dpcs and/or cavity trays using adhesive/mastic in accordance with manufacturer's recommendations to ensure a fully watertight installation.
- Reference: 9000 Stopend Unit (RH/LH)
- Cavity Rise: (150mm or 225mm)
- Cavity Width: (50mm, 75mm and 100mm)

Product Codes

Built in at 150mm rise

Description	Handing	Product Code To suit clear cavity widths of:		
		50mm	75mm	100mm
Stop end units - full height	RH	9010	9012	9014
Stop end units - full height	LH	9011	9013	9015
Stop end units - 75mm high (sloping)	RH	9045 †	9047 †	9049 †
Stop end units - 75mm high (sloping)	LH	9046 †	9048 †	9050 †
Stop end units - 75mm high	Multi	9024	9024	9024 †
Corner units	-	9001	9002	9003
Joint supports	-	9026 †	9027	9028
Change level unit - 75mm step	Multi	9060 †	9063 †	9066
Change level unit - 150mm step	Multi	9061 †	9064 †	9067
Change level unit - 225mm step	Multi	9062 †	9065 †	9068
Gastite sealing tape 15m x 100mm	-	GTAPE01	GTAPE01	GTAPE01

Built in at 225mm rise

Description	Handing	Product Code To suit clear cavity widths of:		
		50mm	75mm	100mm
Stop end units - full height	RH	9018 †	9020 †	9022
Stop end units - full height	LH	9019 †	9021 †	9023
Stop end units - 75mm high (sloping)	RH	9051	9053 †	9055 †
Stop end units - 75mm high (sloping)	LH	9052	9054 †	9056 †
Stop end units - 75mm high	Multi	9024	9024	9024
Corner units	-	9004	9005	9006
Joint supports	-	9030 †	9031 †	9032
Change level unit - 75mm step	Multi	9070	9073	9076
Change level unit - 150mm step	Multi	9071	9074	9067
Change level unit - 225mm step	Multi	9072	9075	9078
Gastite sealing tape 15m x 100mm	-	GTAPE01	GTAPE01	GTAPE01



Scan to view the full product page on the Timloc website

Gas Barrier & Damp Proof Membrane Cavity Tray Systems and Accessories

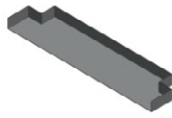
Working in conjunction with radon, methane, CO2 and hydrocarbon gas barrier systems to contain rising gases across the footprint of the building



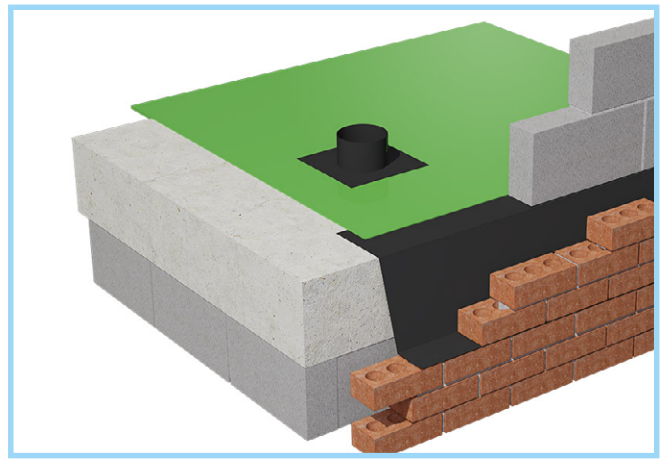
Change of level units



Radon sumps



Threshold internal protection tray TPT01



Use

- In areas outlined in BRE document 'Radon' guidance on protective measures in new dwellings
- When gas protection is required across the footprint of the building
- Crossing cavity wall constructions to maintain gas barrier integrity
- Forming internal perimeter trays to allow membranes continuity
- Following a risk assessment where the requirement is for a good gas protection measure against Radon, Co2, Methane and Hydrocarbon
- To be designed and installed in a continuous system around the whole building perimeter

Features and Benefits

- Preformed mouldings eliminate the need for site fabrication to prevent errors through poor workmanship
- Easy to handle, flexible, tough, durable and puncture resistant
- Can be used for multi-storey or high-loading applications – will not extrude under high loads up to the point of compression failure of wall
- Range of standard components with special tailor made accessories available
- Fully itemised scheduling service

Quality

- Manufactured to BS EN ISO 9001 and BS EN ISO 14001
- Satisfies all NHBC requirements
- Meets BRE requirements
- Complies with Building Regulation Approved Documents C1 and C2
- Meets all relevant British Standards

Material and Colour Choice

- Formed in 2mm medium density polyethylene and/or polypropylene
- Available in black only

Installation Advice

- Units will require tape and seal - tape sold separately.
- Gtape01 to make the seal between joint surfaces
- Gtape02 to seal upper surface to minimise lap lifting if used in concrete floors

Products in the Range

Preformed cavity tray system

Works by reducing on site exposure to the membrane through the use of independent preformed and rigid cavity trays installed to the perimeter of the building, in both the cavity wall with our PCT range and installed at the slab edging with our SPT range.

PCT Range - Horizontal cavity wall perimeter trays

Supplied in 2.5 metre lengths and manufactured from heavy duty 2mm polypropylene. They should be installed continuously around the external perimeter of a building to allow the membrane to be laid at a later stage and so prevent damage as building works proceeds. **Corners - PCT and SPT ranges** Available in both SPT and PCT ranges and manufactured from heavy duty 2mm polyethylene. The standard corners are 90° but a wide range of options are available and selection is by cavity size, wall construction and damp proof course or slab rise required.

Stopends & change of level units

Available in the PCT range and manufactured from heavy duty 2mm PP. Suitable if breaks appear in the natural run of the cavity tray system, and available in cavity size and rise options with 75, 150 and 225mm steps.

Radon sumps (RSUMP01)

Prefabricated sumps are required when a sub floor depressurisation is required under full radon protection. The sump is installed beneath the floor slab in non suspended floor applications and vented to atmosphere via a connecting 110mm drainage pipe to an external source and capped off with proprietary products i.e. air bricks & telescopic under floor vents or roof vents.

Threshold internal protection tray (TPT01)

Designed for detailing rebated areas inside door threshold to maintain water and gas tight integrity without having to trim membrane to fit. Due to possible variations in size, threshold dimensions will be required.

Column cloaks (made to order)

Non standard applications can require gas and water integrity around columns and stanchions. Timloc will design and produce rigid preformed units that are user friendly: simply contact our technical department.



Scan to view the full product page on the Timloc website

Gas Barrier & Damp Proof Membrane Cavity Tray Systems and Accessories

Working in conjunction with radon, methane, CO2 and hydrocarbon gas barrier systems to contain rising gases across the footprint of the building

How to Order

- Timloc can prepare a comprehensive schedule and quotation service. Forward full working drawings and specifications to our technical department
- Orders can be established from written quotations by stipulating number issued

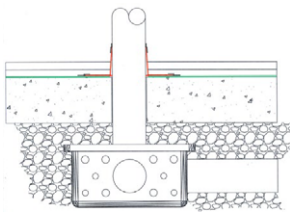
Bill of Quantity

F30 Accessories/sundry items for brick/block/stone walling

Clause

360 GAS RESISTANT CAVITY TRAY ACCESSORIES

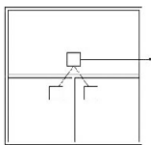
- Manufacturer: Timloc Building Products, Timloc House, Ozone Park, Howden, East Yorkshire, DN14 7SD. T: 01405 765567 W: www.timloc.co.uk
- Reference: e.g. Top hat pipe collar
- Size: e.g. 110mm
- Product code: e.g. TH110
- Use: For use in all types of floor construction to protect buildings against gas penetration from the ground. To cover the full footprint of the building and to incorporate proprietary accessories for pipe, vent protrusions.



Radon sump illustrating horizontal and vertical 110mm soil pipe for venting with **top hat collar**

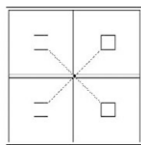
The minimum number of sumps required is 1 per dwelling, but this will be dependent on the foundation construction of the building.

3x sumps req.



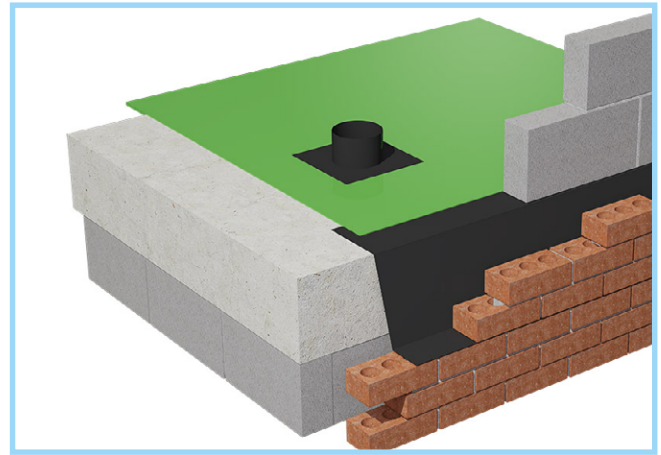
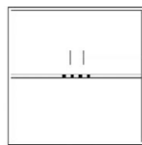
Vented load-bearing masonry

4x sumps req.



Non-vented load-bearing masonry

single sump req.



Product Codes

Description	Product Code
Threshold internal protection tray 930mm	TPT01
Gastite sealing tape 15m x 100mm	GTAPE01
Girth tape 75m x 50mm	GTAPE02

Product codes to suit cavity widths of:	50mm	75mm	100mm
PCT150 Perimeter cavity tray 150mm rise	5101	5102	5103
PCT150 External 90° corner cavity tray	5110	5112	5114
PCT150 Internal 90° corner cavity tray	5111	5113	5115
PCT150 Cavity tray stopend RH	5130	5132	5134
PCT150 Cavity tray stopend LH	5131	5133	5135
PCT150 Change of level 75mm step	9060	9063	9066
PCT150 Change of level 150mm step	9061	9064	9067
PCT150 Change of level 225mm step	9062	9065	9068
PCT225 Perimeter cavity tray 225mm rise	5104	5105	5106
PCT225 External 90° corner cavity tray	5116	5118	5120
PCT225 Internal 90° corner cavity tray	5117	5119	5121
PCT225 Cavity tray stopend RH	5136	5138	5140
PCT225 Cavity tray stopend LH	5137	5139	5141
PCT225 Change of level 75mm step	9070	9073	9076
PCT225 Change of level 150mm step	9071	9074	9077
PCT225 Change of level 225mm step	9072	9075	9078

METER BOXES by timloc

Product	Page No.
Electric Meter Box – Recessed	164
Electric Meter Box – Surface Mounted	165
Gas Meter Box – Recessed	166
Gas Meter Box – Surface Mounted	167
Gas Meter Box – Universal Smart	168
Meter Box Hockey Sticks	169
Electric 3 Phase Meter Box – Surface Mounted	170
Electric 3 Phase Meter Box – Recessed	171

SCAN
TO VIEW



**CATEGORY
GUIDE**

AVAILABLE



Electric Meter Box | Recessed

Designed to house UK standard domestic electric meters

Use

- Designed to house UK standard domestic single phase electric meters

Features and Benefits

- Supplied fully assembled with door fitted
- Compliant to British Standard BS 8567:2012
- Fire retardant to BS 476, Part. 7, 1997, Class 2
- Suitable for all standard domestic meters including prepay and smart
- Will not corrode, weather resistant
- Easily cleaned and can be painted
- Cable entry and meter tail positions are predrilled and supplied with in-fill cap, cable entry position via hockey stick (not supplied)
- Complete with timber backboard, lock and key
- Pin hinges on left

Quality

- Satisfies all NHBC requirements
- Manufactured to BS EN ISO 9001:2015
- Complies with all relevant Building Regulations
- Meets all relevant British Standards

Material and Colour Choice

- Manufactured from hot pressed glass reinforced plastic (GRP)
- Available in white only

Installation Advice

- This meter box should only be fitted by a suitably qualified person
- Minimum wall cut out of 535mm x 365mm required
- Build the box into the wall in the position specified, ensuring it does not bridge the damp proof course
- The base and sides of the box should be fully bedded into the mortar to hold it into the wall with the sides of the architrave touching the outer leaf of the brickwork
- A suitable Timloc cavity tray should be fitted as a damp proof course above and behind the box.
- Where a spigot is fitted, build the inner wall around it, filling any space between the spigot and the wall with mortar

Dimensions

- Overall: 595mm x 409mm x 210mm (H x W x D)
- Recessed: 530mm x 363mm 150mm (H x W x D)

How To Order

- Order as each
- State product codes
- Supplied boxed and assembled with door

Disclaimer

- Due to the composition of GRP, surface blemishes including light scratches and pin holes should be anticipated on the meter box. These are inherent in the manufacturing process and will not affect the overall product functionality.

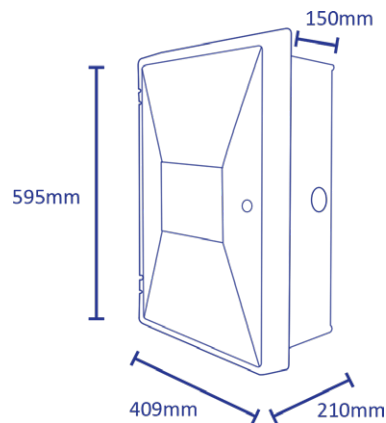


Product Codes

Description	Colour	Product Code
Electric meter box - Recessed	White	30011
Replacement door - 549 x 383mm*	White	30008

*Pin hinge fitting only - Not suitable for butt hinge type.

Product Dimensions



Scan to view the full product page on the Timloc website

Electric Meter Box | Surface Mounted

Designed to house UK standard domestic electric meters

Use

- Designed to house UK standard domestic single phase electric meters

Features and Benefits

- Supplied fully assembled with door fitted
- Compliant to British Standard BS 8567:2012
- Fire retardant to BS 476, Part. 7, 1997, Class 2
- Suitable for all standard domestic meters including prepay and smart
- Will not corrode, weather resistant
- Easily cleaned and can be painted
- Cable entry position via hockey stick (not supplied)
- Complete with timber backboard, lock and key
- Pin hinges on left

Quality

- Satisfies all NHBC requirements
- Manufactured to BS EN ISO 9001-2015
- Complies with all relevant Building Regulations
- Meets all relevant British Standards

Material and Colour Choice

- Manufactured from hot pressed glass reinforced plastic (GRP)
- Available in white only

Installation Advice

- This meter box should only be fitted by a suitably qualified person
- Back plate must be removed prior to installation and fixed to the wall
- Box should be fitted so that it is level with its base, ideally 500mm and 1500mm from the finished level
- Using the back plate for reference, mark the fixing holes on the wall, box must be level. Drill and plug the wall
- Secure box to the wall

Dimensions

- Overall: 595mm x 410mm x 220mm (H x W x D)

How To Order

- Order as each
- State product codes
- Supplied boxed and assembled with door

Disclaimer

- Due to the composition of GRP, surface blemishes including light scratches and pin holes should be anticipated on the meter box. These are inherent in the manufacturing process and will not affect the overall product functionality.



Replacement doors available



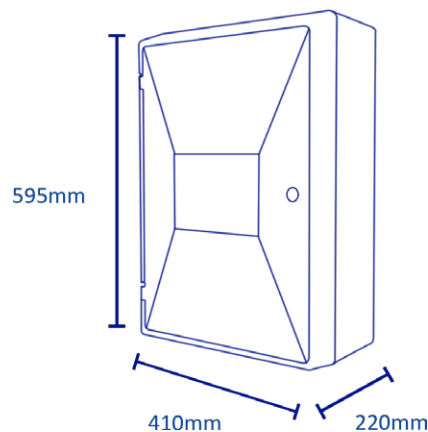
Sold in single quantities and individually boxed

Product Codes

Description	Colour	Product Code
Electric meter box - Surface mounted	White	30012
Replacement door - 549 x 383mm*	White	30008

*Pin hinge fitting only - Not suitable for butt hinge type.

Product Dimensions



Scan to view the full product page on the Timloc website

Gas Meter Box | Recessed

Designed to house UK standard domestic gas meters

Use

- Designed to house UK standard domestic single phase gas meters

Features and Benefits

- Supplied fully assembled with door fitted
- Compliant to British Standard BS 8567:2012
- Fire retardant to BS 476, Part. 7, 1997, Class 2
- Suitable for all standard domestic meters including prepay and smart
- Will not corrode, weather resistant
- Easily cleaned and can be painted
- Complete with spigot, lock and key
- Pin hinges on right

Quality

- Satisfies all NHBC requirements
- Manufactured to BS EN ISO 9001:2015
- Complies with all relevant Building Regulations
- Meets all relevant British Standards

Material and Colour Choice

- Manufactured from hot pressed glass reinforced plastic (GRP)
- Available in white only

Installation Advice

- This meter box should only be fitted by a suitably qualified person
- Minimum wall cut out of 535mm x 365mm required
- Build the box into the wall in the position specified, ensuring it does not bridge the damp proof course
- The base and sides of the box should be fully bedded into the mortar to hold it into the wall with the sides of the architrave touching the outer leaf of the brickwork
- A suitable Timloc cavity tray should be fitted as a damp proof course above and behind the box.
- Where a spigot is fitted, build the inner wall around it, filling any space between the spigot and the wall with mortar

Dimensions

- Overall: 595mm x 409mm x 214mm (H x W x D)
- Recessed: 530mm x 363 x 150mm (H x W x D)

How To Order

- Order as each
- State product codes
- Supplied boxed and assembled with door

Product Codes

Description	Colour	Product Code
Gas meter box - Recessed	White	30013
Replacement door - 549 x 383mm	White	30014

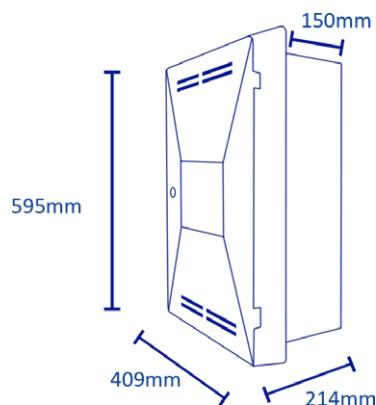
*Pin hinge fitting only - Not suitable for butt hinge type.



Disclaimer

- Due to the composition of GRP, surface blemishes including light scratches and pin holes should be anticipated on the meter box. These are inherent in the manufacturing process and will not affect the overall product functionality.

Product Dimensions



Scan to view the full product page on the Timloc website

Gas Meter Box | Surface Mounted

Designed to house UK standard domestic gas meters

Use

- Designed to house UK standard domestic single phase gas meters

Features and Benefits

- Supplied fully assembled with door fitted
- Compliant to British Standard BS 8567:2012
- Fire retardant to BS 476, Part. 7, 1997, Class 2
- Suitable for all standard domestic meters including prepay and smart
- Will not corrode, weather resistant
- Easily cleaned and can be painted
- Complete with MK2 back plates, lock and key
- Three part box - Door, box and back
- Pin hinges on right

Quality

- Satisfies all NHBC requirements
- Manufactured to BS EN ISO 9001:2015
- Complies with all relevant Building Regulations
- Meets all relevant British Standards

Material and Colour Choice

- Manufactured from hot pressed glass reinforced plastic (GRP)
- Available in white only

Installation Advice

- This meter box should only be fitted by a suitably qualified person
- Back plate must be removed prior to installation and fixed to the wall
- Box should be fitted so that it is level with its base, ideally 500mm and 1500mm from the finished level
- Using the back plate for reference, mark the fixing holes on the wall, box must be level. Drill and plug the wall

Dimensions

- Overall: 510mm x 408mm x 242mm (H x W x D)

How To Order

- Order as each
- State product codes
- Supplied boxed and assembled with door

Product Codes

Description	Colour	Product Code
Gas meter box - Surface mounted	White	30015
Replacement door - 340 x 380mm	White	30016

*Pin hinge fitting only - Not suitable for butt hinge type.

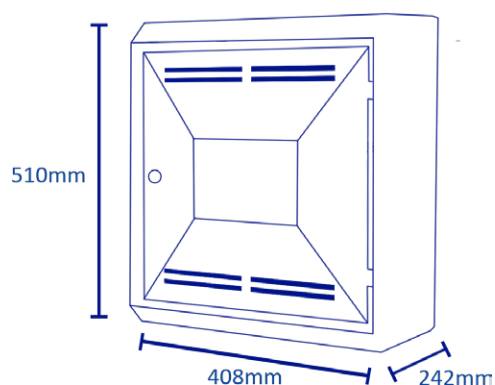
Scan to view the full product page on the Timloc website



Disclaimer

- Due to the composition of GRP, surface blemishes including light scratches and pin holes should be anticipated on the meter box. These are inherent in the manufacturing process and will not affect the overall product functionality.

Product Dimensions



Gas Meter Box | Universal Smart

Designed to house UK standard domestic smart gas meters

Use

- Designed to house UK standard domestic smart gas meters

Features and Benefits

- Designed for the standard smart gas meter installation kits
- Fire retardant to BS476, Part 7, Class 2
- Fitted meter bracket and safety door stay
- Will not corrode, weather resistant
- Easily cleaned
- Complete with hinges, lock and key
- Door opening front to back

Quality

- Satisfies all NHBC requirements
- Manufactured to BS EN ISO 9001-2015
- Complies with all relevant Building Regulations
- Meets all relevant British Standards

Material and Colour Choice

- Manufactured from hot pressed glass reinforced plastic (GRP)
- Available in off-white only

Installation Advice

- This meter box should only be fitted by a suitably qualified person

Dimensions

- Overall: 500mm x 474mm x 303mm (H x W x D)

How To Order

- Order as each
- State product codes
- Supplied boxed and assembled with door

Disclaimer

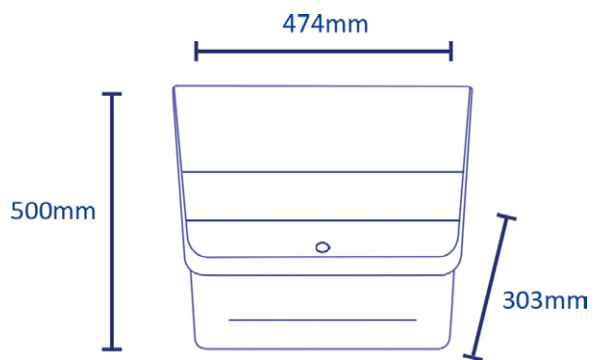
- Due to the composition of GRP, surface blemishes including light scratches and pin holes should be anticipated on the meter box. These are inherent in the manufacturing process and will not affect the overall product functionality.



Product Codes

Description	Colour	Product Code
Gas meter box - Universal Smart	White	30017
Replacement door - 549 x 383mm	White	30018

Product Dimensions



Scan to view the full product page on the Timloc website

Meter Box Hockey Stick

Designed to suit cable entry into meter box

Use

- Designed to suit cable entry into meter box

Quality

- Satisfies all NHBC requirements
- Manufactured to BS EN ISO 9001-2015
- Complies with all relevant Building Regulations
- Meets all relevant British Standards

Material and Colour Choice

- Manufactured from UPVC
- 31001 - Black | 31002 - Off-white

Installation Advice

- Hockey sticks should only be fitted by a suitably qualified person

Dimensions

- 31001: 1200mm x 480mm x 38mm (H x W x D)
- 31002: 1450mm x 310mm x 38mm (H x W x D)

How To Order

- Order as each
- State product codes

Product Codes

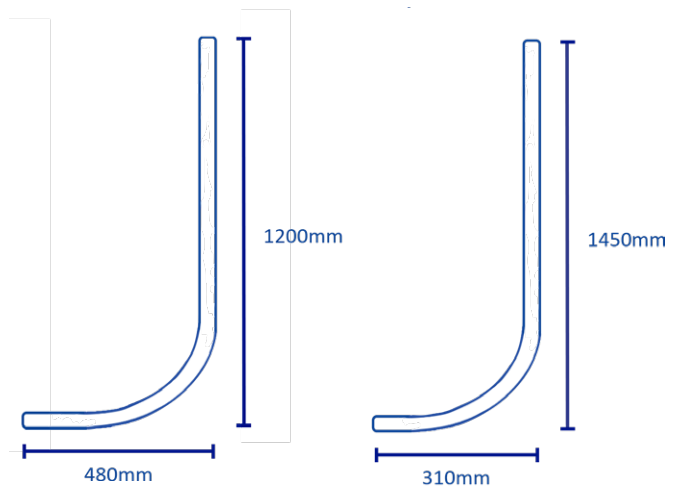
Description	Colour	Product Code
Internal Cavity Hockey Stick	Black	31001
Surface Mounted Hockey Stick	White	31002



Sold in single units and packaged in a sleeve

Product Dimensions

31001 - Internal Cavity Hockey Stick 31002 - Surface Mounted Hockey Stick



Scan to view the full product page on the Timloc website

Electric Meter Box | 3 Phase Surface Mounted

Designed to house 3 phase electric meters

Use

- Designed to house 3 phase electric meters

Features and Benefits

- Supplied fully assembled with door fitted
- Compliant to British Standard BS 8567:2012
- Fire retardant to BS 476, Part. 7, 1997, Class 2
- Complies to ESI standard 12-3 April, 1986
- Suitable for all meters including prepay and smart
- Will not corrode, weather resistant
- Easily cleaned and can be painted
- Multiple cable knock out positions
- Complete with timber backboard, lock and key
- Hinges on right

Quality

- Manufactured to BS EN ISO 9001-2015
- Complies with all relevant Building Regulations
- Meets all relevant British Standards

Material and Colour Choice

- Manufactured from hot pressed glass reinforced polymer (GRP)
- Available in white only

Installation Advice

- This meter box should only be fitted by a suitably qualified person
- Back plate must be removed prior to installation and fixed to the wall
- Box should be fitted so that it is level with its base, ideally 500mm and 1500mm from the finished level
- Using the back plate for reference, mark the fixing holes on the wall, box must be level. Drill and plug the wall
- Secure box to the wall

Dimensions

- Overall: 794mm x 565mm x 190mm (H x W x D)

How To Order

- Order as each
- 30003 available in pack quantities only
- State product codes
- Individually boxed and assembled with door

Disclaimer

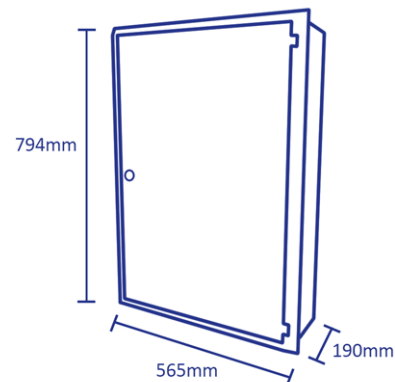
- Due to the composition of GRP, surface blemishes including light scratches and pin holes should be anticipated on the meter box. These are inherent in the manufacturing process and will not affect the overall product functionality.

Product Codes

Description	Colour	Box Quantity	Pack Quantity	Lead Time	Product Code
Electric meter box - Large 3 phase surface mounted	White	1	2	Next Working Day	30003



Product Dimensions



Scan to view the full product page on the Timloc website

Electric Meter Box | 3 Phase Recessed

Designed to house 3 phase electric meters

Use

- Designed to house 3 phase electric meters

Features and Benefits

- Supplied fully assembled with door fitted
- Compliant to British Standard BS 8567:2012
- Fire retardant to BS 476, Part. 7, 1997, Class 2
- Complies to ESI standard 12-3 April, 1986
- Suitable for all meters including prepay and smart
- Will not corrode, weather resistant
- Easily cleaned and can be painted
- Multiple cable knock out positions
- Complete with timber backboard, lock and key
- Hinges on right

Quality

- Manufactured to BS EN ISO 9001-2015
- Complies with all relevant Building Regulations
- Meets all relevant British Standards

Material and Colour Choice

- Manufactured from hot pressed glass reinforced plastic (GRP)
- Available in white only

Installation Advice

- This meter box should only be fitted by a suitably qualified person
- Minimum wall cut out of 715mm x 485mm required
- Build the box into the wall in the position specified, ensuring it does not bridge the damp proof course
- The base and sides of the box should be fully bedded into the mortar to hold it into the wall with the sides of the architrave touching the outer leaf of the brickwork
- A suitable Timloc cavity tray should be fitted as a damp proof course above and behind the box.
- Where a spigot is fitted, build the inner wall around it, filling any space between the spigot and the wall with mortar

Dimensions

- Overall: 794mm x 565mm x 180mm (H x W x D)

How To Order

- Order as each
- 30002 available in pack quantities only
- State product codes
- Individually boxed and assembled with door

Disclaimer

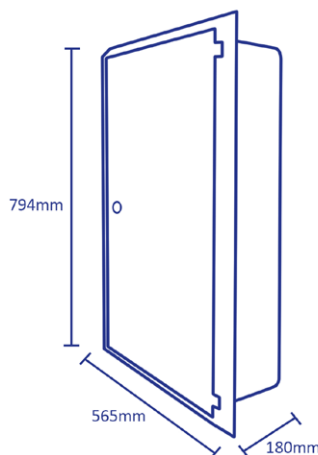
- Due to the composition of GRP, surface blemishes including light scratches and pin holes should be anticipated on the meter box. These are inherent in the manufacturing process and will not affect the overall product functionality.

Product Codes

Description	Colour	Box Quantity	Pack Quantity	Lead Time	Product Code
Electric meter box 3 phase recessed	White	1	4	Next Working Day	30002



Product Dimensions



Scan to view the full product page on the Timloc website

LIFETIME, NOT SINGLE-USE

At Timloc Building Products, we take our responsibility for the environment seriously and are committed to making positive steps to help reduce plastic waste within the building industry.

We are proud to manufacture products that are made to last and are predominantly from recycled plastics.

Our products are designed for use throughout the lifespan of a home and are recyclable at the end of the building life.

As part of our ongoing sustainability initiative, we have produced the 'Hedgehog Highway by Timloc' to help tackle the declining number of our prickly friends across the UK.

Multiple-use
products
designed for
the **lifespan** of
the building.



For more information on Timloc's sustainability commitment please visit:
timloc.co.uk/sustainability

HEDGEHOG HIGHWAY

by **timloc**

Helping hedgehogs roam from garden to garden

Use

- To frame fence holes designed to connect gardens, enabling hedgehogs to roam freely and forage for food and shelter without restriction

Features and Benefits

- Effective, quick and easy to fit
- Makes a feature of the purpose-made hole and clarifies its objective, in turn helping to avoid accidental obstruction
- Durable and totally resistant to decay
- Manufactured from 100% recycled plastic

Quality

- Manufactured to BS EN ISO 9001 and BS EN ISO 14001

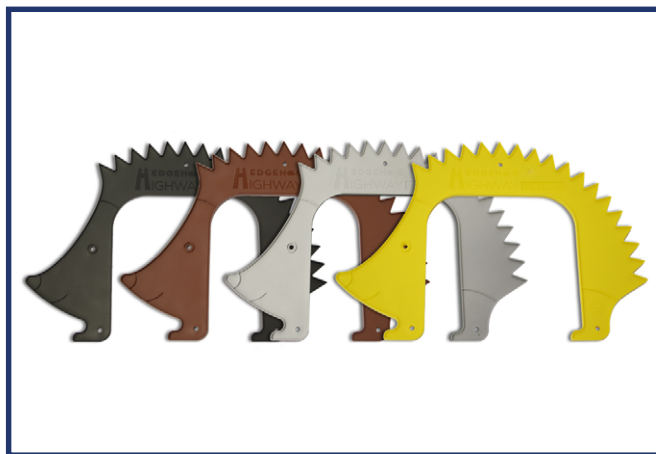
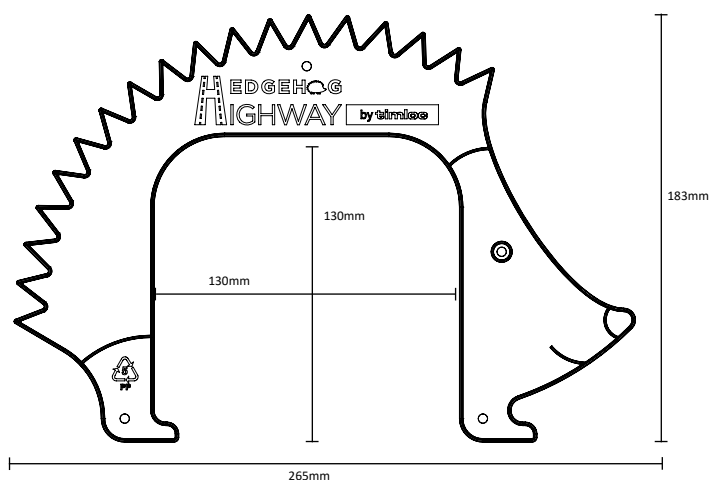
Material and Colour Choice

- Manufactured from recycled Polypropylene
- Available in Black, Brown, Grey or Yellow

Installation Advice

- Cut a 130mm x 130mm square hole in the bottom of the garden fence or wall - use the Hedgehog Highway by Timloc as a guide
- Line up the Hedgehog Highway by Timloc with the hole and secure into place with screws (not provided)

Product Dimensions



How to Order

- Contact our sales team or visit the dedicated Hedgehog Highway by Timloc web page for details of how to order:

www.timloc.co.uk/sustainability/hedgehog-highway-by-timloc

Product Codes

Pack Quantity	Colour	Product Code
1	Black	5551
2	Black	5552
1	Brown	7771
2	Brown	7772
1	Yellow	8881
2	Yellow	8882
1	Grey	9991
2	Grey	9992

A donation from the sale of each Hedgehog Highway by Timloc will be made to hedgehog rescue centres and support organisations across the UK.



Scan to view the full product page on the Timloc website

PRODUCT CODES

Product Codes

Individual codes for the entire Timloc product range

Construction Accessories

Description	Colour	Quantity	Lead Time	Product Code	Page No.
Invisiweep Cavity Wall Weep	Blue Black	50	Next Working Day	IW50BB	9
Invisiweep Cavity Wall Weep	Black	50	Next Working Day	IW50BL	9
Invisiweep Cavity Wall Weep	Brown	50	Next Working Day	IW50BR	9
Invisiweep Cavity Wall Weep	Buff	50	Next Working Day	IW50BU	9
Invisiweep Cavity Wall Weep	Clear	50	Next Working Day	IW50CL	9
Invisiweep Cavity Wall Weep	Grey	50	Next Working Day	IW50GR	9
Invisiweep Cavity Wall Weep	Terracotta	50	Next Working Day	IW50TE	9
Invisiweep Cavity Wall Weep	White	50	Next Working Day	IW50WH	9
Invisiweep Cavity Wall Weep	Blue Black	200	Next Working Day	IW200BB	9
Invisiweep Cavity Wall Weep	Black	200	Next Working Day	IW200BL	9
Invisiweep Cavity Wall Weep	Brown	200	Next Working Day	IW200BR	9
Invisiweep Cavity Wall Weep	Buff	200	Next Working Day	IW200BU	9
Invisiweep Cavity Wall Weep	Clear	200	Next Working Day	IW200CL	9
Invisiweep Cavity Wall Weep	Grey	200	Next Working Day	IW200GR	9
Invisiweep Cavity Wall Weep	Terracotta	200	Next Working Day	IW200TE	9
Invisiweep Cavity Wall Weep	White	200	Next Working Day	IW200WH	9
Invisiweep Extension Tube 500mm	Clear	10	Next Working Day	IW500EX	9
Invisiweep NC Non-Combustible Cavity Wall Weep	Silver	50	Next Working Day	ZIN50	10
Cavity Wall Weep Vent	Blue Black	50	Next Working Day	1143BB	11
Cavity Wall Weep Vent	Black	50	Next Working Day	1143BL	11
Cavity Wall Weep Vent	Brown	50	Next Working Day	1143BR	11
Cavity Wall Weep Vent	Buff	50	Next Working Day	1143BU	11
Cavity Wall Weep Vent	Clear	50	Next Working Day	1143CL	11
Cavity Wall Weep Vent	Grey	50	Next Working Day	1143GR	11
Cavity Wall Weep Vent	Terracotta	50	Next Working Day	1143TE	11
Cavity Wall Weep Vent	White	50	Next Working Day	1143WH	11
Cavity Wall Weep Vent Extension 50mm	Natural	50	Next Working Day	1144	11
Drill Vent by Timloc	Clear	50	Next Working Day	DV1	12
Drill Vent by Timloc	Buff	50	Next Working Day	DV2	12
Drill Vent by Timloc	Terracotta	50	Next Working Day	DV3	12
Insulation Retaining Discs 65mm	Black	1500	Next Working Day	IRD65BL	13
Insulation Retaining Discs 80mm	Red	1000	Next Working Day	IRD80R	13
1201 Airbrick	Blue Black	20	Next Working Day	1201ABBB	14
1201 Airbrick	Black	20	Next Working Day	1201ABBL	14
1201 Airbrick	Brown	20	Next Working Day	1201ABBR	14
1201 Airbrick	Buff	20	Next Working Day	1201ABBU	14
1201 Airbrick	Grey	20	Next Working Day	1201ABGR	14
1201 Airbrick	Terracotta	20	Next Working Day	1201ABTE	14
1201 Airbrick	White	20	Next Working Day	1201ABWH	14
1201 Telescopic Underfloor Ventilator	Black	20	Next Working Day	1201	15
1201XL Telescopic Underfloor Ventilator	Black	10	Next Working Day	1201XL	16
1201XL+ Telescopic Underfloor Ventilator	Black	10	Next Working Day	1201XL+	17
1201 Underfloor Vent Horizontal Front Extension +115mm	Black	20	Next Working Day	1203	18
1201 Underfloor Vent Vertical Extension +150mm	Black	20	Next Working Day	1204	18
1201 Underfloor Vent Duct Adapter to suit 110mm diameter	Black	1	Next Working Day	1205	18
1201 Underfloor Vent Horizontal Rear Extension +100mm	Black	1	Next Working Day	1206	18

Cavity Trays

Description	Colour	Quantity	Lead Time	Product Code	Page No.
Everdry 225mm Intermediate Cavity Tray Brickwork - RH	Black	1	Next Working Day	10001	22
Everdry 225mm Intermediate Cavity Tray Brickwork - LH	Black	1	Next Working Day	10002	22
Everdry 420mm Intermediate Cavity Tray Brickwork - RH	Black	1	Next Working Day	10011	22
Everdry 420mm Intermediate Cavity Tray Brickwork - LH	Black	1	Next Working Day	10012	22
Everdry 225mm Stop End Starter Cavity Tray Brickwork - RH & LH	Black	1	Next Working Day	10031	22
Everdry 225mm Corner Starter Cavity Tray Brickwork - RH & LH	Black	1	Next Working Day	10041	22
Everdry 225mm Ridge Cavity Tray Brickwork	Black	1	Next Working Day	10061	22
Everdry 420mm Ridge Cavity Tray Brickwork	Black	1	Next Working Day	10062	22
Everdry 225mm Intermediate Cavity Tray Brickwork - RH - With Polystrip	Black	1	Next Working Day	10001P	22
Everdry 225mm Intermediate Cavity Tray Brickwork - LH - With Polystrip	Black	1	Next Working Day	10002P	22
Everdry 420mm Intermediate Cavity Tray Brickwork - RH - With Polystrip	Black	1	Next Working Day	10011P	22
Everdry 420mm Intermediate Cavity Tray Brickwork - LH - With Polystrip	Black	1	Next Working Day	10012P	22

CONSTRUCTION ACCESSORIES

CAVITY TRAYS

CAVITY CLOSERS

ACCESS PRODUCTS

ADAPT-AIR

RAD-SEAL

ROOFLINE

THROUGH-WALL VENTILATION

TOP HATS, GAS BARRIERS & DPC

METER BOXES

	Description	Colour	Quantity	Lead Time	Product Code	Page No.
CONSTRUCTION ACCESSORIES	Everdry 225mm Stop End Starter Cavity Tray Brickwork - RH & LH - With Polystrip	Black	1	Next Working Day	10031P	22
	Everdry 225mm Corner Starter Cavity Tray Brickwork - RH & LH - With Polystrip	Black	1	Next Working Day	10041P	22
	Everdry 225mm Ridge Cavity Tray Brickwork - With Polystrip	Black	1	Next Working Day	10061P	22
CAVITY TRAYS	Everdry 420mm Ridge Cavity Tray Brickwork - With Polystrip	Black	1	3 - 5 Working Days	10062P	22
	Everdry 450mm Intermediate Cavity Tray Stonework	Black	1	Next Working Day	7101-7102	24
	Everdry 450mm Intermediate Cavity Tray Stonework	Black	1	3 - 5 Working Days	7103-7104	24
	Everdry 450mm Intermediate Cavity Tray Stonework	Black	1	Next Working Day	7105-7106	24
	Everdry 450mm Intermediate Cavity Tray Stonework	Black	1	3 - 5 Working Days	7107-7110	24
	Everdry 625mm Intermediate Cavity Tray Stonework	Black	1	3 - 5 Working Days	7111-7120	24
	Everdry 1250mm Intermediate Cavity Tray Stonework	Black	1	3 - 5 Working Days	7121-7130	24
CAVITY CLOSERS	Everdry 450mm Stop End Starter Cavity Tray Stonework - RH & LH	Black	1	Next Working Day	7131	24
	Everdry 450mm Stop End Starter Cavity Tray Stonework - RH & LH	Black	1	3 - 5 Working Days	7132-7134	24
	Everdry 450mm Stop End Starter Cavity Tray Stonework - RH & LH	Black	1	Next Working Day	7135	24
	Everdry 450mm Stop End Starter Cavity Tray Stonework - RH & LH	Black	1	3 - 5 Working Days	7136-7139	24
	Everdry 550mm Corner Starter Cavity Tray Stonework - RH & LH	Black	1	Next Working Day	7141	24
	Everdry 550mm Corner Starter Cavity Tray Stonework - RH & LH	Black	1	3 - 5 Working Days	7142-7150	24
	Everdry 450mm Ridge Stonework Cavity Tray	Black	1	Next Working Day	7161	24
	Everdry 450mm Ridge Stonework Cavity Tray	Black	1	3 - 5 Working Days	7162-7165	24
	Everdry 450mm Intermediate Cavity Tray Stonework - With Polystrip	Black	1	Next Working Day	7101P-7102P	24
	Everdry 450mm Intermediate Cavity Tray Stonework - With Polystrip	Black	1	3 - 5 Working Days	7103P-7110P	24
ACCESS PRODUCTS	Everdry 625mm Intermediate Cavity Tray Stonework - With Polystrip	Black	1	3 - 5 Working Days	7111P-7120P	24
	Everdry 1250mm Intermediate Cavity Tray Stonework - With Polystrip	Black	1	3 - 5 Working Days	7121P-7130P	24
	Everdry 450mm Stop End Starter Cavity Tray Stonework - RH & LH - With Polystrip	Black	1	Next Working Day	7131P	24
	Everdry 450mm Stop End Starter Cavity Tray Stonework - RH & LH - With Polystrip	Black	1	3 - 5 Working Days	7132P-7139P	24
	Everdry 550mm Corner Starter Cavity Tray Stonework - RH & LH - With Polystrip	Black	1	3 - 5 Working Days	7141P-7150P	24
	Everdry 450mm Ridge Cavity Tray Stonework - With Polystrip	Black	1	Next Working Day	7161P	24
	Everdry 450mm Ridge Cavity Tray Stonework - With Polystrip	Black	1	3 - 5 Working Days	7162P-7165P	24
	Everdry 625mm Intermediate Cavity Tray Blockwork	Black	1	Next Working Day	7201-7202	26
	Everdry 625mm Intermediate Cavity Tray Blockwork	Black	1	3 - 5 Working Days	7203-7210	26
	Everdry 1250mm Intermediate Cavity Tray Blockwork	Black	1	3 - 5 Working Days	7211-7220	26
ADAPT-AIR	Everdry 450mm Stop End Starter Cavity Tray Blockwork - RH & LH	Black	1	Next Working Day	7231	26
	Everdry 450mm Stop End Starter Cavity Tray Blockwork - RH & LH	Black	1	3 - 5 Working Days	7232-7239	26
	Everdry 550mm Corner Starter Cavity Tray Blockwork - RH & LH	Black	1	3 - 5 Working Days	7241-7250	26
	Everdry 625mm Ridge Blockwork Cavity Tray	Black	1	Next Working Day	7261	26
	Everdry 625mm Ridge Blockwork Cavity Tray	Black	1	3 - 5 Working Days	7262-7265	26
	Everdry 625mm Intermediate Cavity Tray Blockwork - With Polystrip	Black	1	3 - 5 Working Days	7201P-7210P	26
	Everdry 1250mm Intermediate Cavity Tray Blockwork - With Polystrip	Black	1	3 - 5 Working Days	7211P-7220P	26
	Everdry 450mm Stop End Starter Cavity Tray Blockwork - RH & LH - With Polystrip	Black	1	3 - 5 Working Days	7231P-7239P	26
	Everdry 550mm Stop End Starter Cavity Tray Blockwork - RH & LH - With Polystrip	Black	1	3 - 5 Working Days	7241P-7250P	26
	Everdry 625mm Ridge Cavity Tray Blockwork - With Polystrip	Black	1	3 - 5 Working Days	7261P-7265P	26
RAD-SEAL	Inter-loc Horizontal Cavity Tray 2 Brick - New Build	Black	1	Next Working Day	IL2	34
	Inter-loc Horizontal Cavity Tray 4 Brick - New Build	Black	1	Next Working Day	IL4	34
	Inter-loc Horizontal 90° External Corner Cavity Tray - New Build	Black	1	Next Working Day	EXT90	34
	Inter-loc Horizontal 90° Internal Corner Cavity Tray - New Build	Black	1	Next Working Day	INT90	34
	Inter-loc Horizontal 135° External Corner Cavity Tray - New Build	Black	1	3 - 5 Working Days	EXT135	34
	Inter-loc Horizontal 135° Internal Corner Cavity Tray - New Build	Black	1	3 - 5 Working Days	INT135	34
	Inter-loc Horizontal Stop End Cavity Tray - RH - New Build & Refurb	Black	1	Next Working Day	SERH	34
	Inter-loc Horizontal Stop End Cavity Tray - LH - New Build & Refurb	Black	1	Next Working Day	SELH	34
	Inter-loc Horizontal Cavity Tray 2 Brick - Refurb	Black	1	Next Working Day	IL2/E	34
	Inter-loc Horizontal 90° External Corner Cavity Tray - Refurb	Black	1	Next Working Day	EXT90/E	34
ROOFLINE	Inter-loc Horizontal 90° Int Corner Cavity Tray - Refurb	Black	1	Next Working Day	INT90/E	34
	Inter-loc Horizontal Cavity Tray 2 Brick - New Build - With Polystrip	Black	1	Next Working Day	IL2P	34
	Inter-loc Horizontal Cavity Tray 4 Brick - New Build - With Polystrip	Black	1	Next Working Day	IL4P	34
	Inter-loc Horizontal 90° External Corner Cavity Tray - New Build - With Polystrip	Black	1	Next Working Day	EXT90P	34
	Inter-loc Horizontal 90° Internal Corner Cavity Tray - New Build - With Polystrip	Black	1	Next Working Day	INT90P	34
	System 2000 460mm Horizontal Cavity Tray New Build - 50-74mm	Black	1	Next Working Day	2075/460/50	36
	System 2000 460mm Horizontal Cavity Tray New Build - 75-99mm	Black	1	Next Working Day	2075/460/75	36
	System 2000 460mm Horizontal Cavity Tray New Build - 100-124mm	Black	1	Next Working Day	2075/460/100	36
	System 2000 460mm Horizontal Cavity Tray New Build - 125-150mm	Black	1	3 - 5 Working Days	2075/460/150	36
	System 2000 880mm Horizontal Cavity Tray New Build - 50-74mm	Black	1	Next Working Day	2075/880/50	36
THROUGH-WALL VENTILATION	System 2000 880mm Horizontal Cavity Tray New Build - 75-99mm	Black	1	Next Working Day	2075/880/75	36
	System 2000 880mm Horizontal Cavity Tray New Build - 100-124mm	Black	1	Next Working Day	2075/880/100	36
	System 2000 880mm Horizontal Cavity Tray New Build - 125-150mm	Black	1	3 - 5 Working Days	2075/880/150	36
	System 2000 Horizontal External 90° Corner Cavity Tray - 50-74mm	Black	1	Next Working Day	2010/50	36
	System 2000 Horizontal External 90° Corner Cavity Tray - 75-99mm	Black	1	Next Working Day	2010/75	36
	System 2000 Horizontal External 90° Corner Cavity Tray - 100-124mm	Black	1	Next Working Day	2010/100	36
	System 2000 460mm Horizontal Cavity Tray New Build - 50-74mm	Black	1	Next Working Day	2075/460/50	36
	System 2000 460mm Horizontal Cavity Tray New Build - 75-99mm	Black	1	Next Working Day	2075/460/75	36
	System 2000 460mm Horizontal Cavity Tray New Build - 100-124mm	Black	1	Next Working Day	2075/460/100	36
	System 2000 460mm Horizontal Cavity Tray New Build - 125-150mm	Black	1	3 - 5 Working Days	2075/460/150	36
TOP HATS, GAS BARRIERS & DPC	System 2000 880mm Horizontal Cavity Tray New Build - 50-74mm	Black	1	Next Working Day	2075/880/50	36
	System 2000 880mm Horizontal Cavity Tray New Build - 75-99mm	Black	1	Next Working Day	2075/880/75	36
	System 2000 880mm Horizontal Cavity Tray New Build - 100-124mm	Black	1	Next Working Day	2075/880/100	36
	System 2000 880mm Horizontal Cavity Tray New Build - 125-150mm	Black	1	3 - 5 Working Days	2075/880/150	36
METER BOXES	System 2000 Horizontal External 90° Corner Cavity Tray - 50-74mm	Black	1	Next Working Day	2010/50	36
	System 2000 Horizontal External 90° Corner Cavity Tray - 75-99mm	Black	1	Next Working Day	2010/75	36
	System 2000 Horizontal External 90° Corner Cavity Tray - 100-124mm	Black	1	Next Working Day	2010/100	36
	System 2000 Horizontal External 90° Corner Cavity Tray - 100-124mm	Black	1	Next Working Day	2010/100	36

Description	Colour	Quantity	Lead Time	Product Code	Page No.
System 2000 Horizontal External 90° Corner Cavity Tray 125-150mm	Black	1	Next Working Day	2010/150	36
System 2000 Horizontal Internal 90° Corner Cavity Tray 50-74mm	Black	1	Next Working Day	2011/50	36
System 2000 Horizontal Internal 90° Corner Cavity Tray 75-99mm	Black	1	Next Working Day	2011/75	36
System 2000 Horizontal Internal 90° Corner Cavity Tray 100-124mm	Black	1	Next Working Day	2011/100	36
System 2000 Horizontal Internal 90° Corner Cavity Tray 125-150mm	Black	1	Next Working Day	2011/150	36
System 2000 Horizontal External 135° Corner Cavity Tray 50-74mm	Black	1	3 -5 Working Days	2012/50	36
System 2000 Horizontal External 135° Corner Cavity Tray 75-99mm	Black	1	3 -5 Working Days	2012/75	36
System 2000 Horizontal External 135° Corner Cavity Tray 100-125mm	Black	1	3 -5 Working Days	2012/100	36
System 2000 Horizontal Internal 135° Corner Cavity Tray 50-74mm	Black	1	3 -5 Working Days	2013/50	36
System 2000 Horizontal Internal 135° Corner Cavity Tray 75-99mm	Black	1	3 -5 Working Days	2013/75	36
System 2000 Horizontal Internal 135° Corner Cavity Tray 100-125mm	Black	1	3 -5 Working Days	2013/100	36
System 2000 Horizontal Cavity Tray Stop End 50-74mm - RH	Black	1	Next Working Day	2003/50	36
System 2000 Horizontal Cavity Tray Stop End 75-99mm - RH	Black	1	Next Working Day	2003/75	36
System 2000 Horizontal Cavity Tray Stop End 100-124mm - RH	Black	1	Next Working Day	2003/100	36
System 2000 Horizontal Cavity Tray Stop End 125-150mm - RH	Black	1	Next Working Day	2003/150	36
System 2000 Horizontal Cavity Tray Stop End 50-74mm - LH	Black	1	Next Working Day	2004/50	36
System 2000 Horizontal Cavity Tray Stop End 75-99mm - LH	Black	1	Next Working Day	2004/75	36
System 2000 Horizontal Cavity Tray Stop End 100-124mm - LH	Black	1	Next Working Day	2004/100	36
System 2000 Horizontal Cavity Tray Stop End 125-150mm - LH	Black	1	Next Working Day	2004/150	36
System 2000 Horizontal Cavity Tray Refurb 460mm 50-74mm	Black	1	Next Working Day	2005/50	37
System 2000 Horizontal Cavity Tray Refurb 460mm 75-99mm	Black	1	Next Working Day	2005/75	37
System 2000 Horizontal Cavity Tray Refurb 460mm 100-125mm	Black	1	Next Working Day	2005/100	37
System 2000 Horizontal External 90° Corner Cavity Tray Refurb 50-74mm	Black	1	3 -5 Working Days	2006E/50	37
System 2000 Horizontal External 90° Corner Cavity Tray Refurb 75-99mm	Black	1	3 -5 Working Days	2006E/75	37
System 2000 Horizontal External 90° Corner Cavity Tray Refurb 100-125mm	Black	1	3 -5 Working Days	2006E/100	37
System 2000 Horizontal Internal 90° Corner Cavity Tray Refurb 50-74mm	Black	1	3 -5 Working Days	2007E/50	37
System 2000 Horizontal Internal 90° Corner Cavity Tray Refurb 75-99mm	Black	1	3 -5 Working Days	2007E/75	37
System 2000 Horizontal Internal 90° Corner Cavity Tray Refurb 100-125mm	Black	1	3 -5 Working Days	2007E/100	37
System 2000 Horizontal PolyStrip Cavity Tray New Build 460mm 50-74mm Cav	Black	1	Next Working Day	2075/460P50	36
System 2000 Horizontal Cavity Tray New Build 460mm 75-99mm - With Polystrip	Black	1	Next Working Day	2075/460P75	36
System 2000 Horizontal Cavity Tray New Build 460mm 100-125mm - With Polystrip	Black	1	Next Working Day	2075/460P100	36
System 2000 Horizontal Cavity Tray New Build 460mm 125-150mm - With Polystrip	Black	1	3 -5 Working Days	2075/460P150	36
System 2000 Horizontal Cavity Tray New Build 880mm 50-74mm - With Polystrip	Black	1	Next Working Day	2075/880P50	36
System 2000 Horizontal Cavity Tray New Build 880mm 75-99mm - With Polystrip	Black	1	Next Working Day	2075/880P75	36
System 2000 Horizontal Cavity Tray New Build 880mm 100-125mm - With Polystrip	Black	1	Next Working Day	2075/880P100	36
System 2000 Horizontal Ext 90° Corner Tray New Build 50-74mm - With Polystrip	Black	1	Next Working Day	2010P/50	36
System 2000 Horizontal Ext 90° Corner Tray New Build 75-99mm - With Polystrip	Black	1	Next Working Day	2010P/75	36
System 2000 Horizontal Ext 90° Corner Tray New Build 100-125mm - With Polystrip	Black	1	Next Working Day	2010P/100	36
System 2000 Horizontal Int 90° Corner Tray New Build 50-74mm - With Polystrip	Black	1	Next Working Day	2011P/50	36
System 2000 Horizontal Int 90° Corner Tray New Build 75-99mm - With Polystrip	Black	1	Next Working Day	2011P/75	36
System 2000 Horizontal Int 90° Corner Tray New Build 100-125mm - With Polystrip	Black	1	Next Working Day	2011P/100	36
System 2000 Horizontal Ext 135° Corner Tray New Build 50-74mm - With Polystrip	Black	1	3 -5 Working Days	2012P/50	36
System 2000 Horizontal Ext 135° Corner Tray New Build 75-99mm - With Polystrip	Black	1	3 -5 Working Days	2012P/75	36
System 2000 Horizontal Ext 135° Corner Tray New Build 100-125mm - With Polystrip	Black	1	3 -5 Working Days	2012P/100	36
System 2000 Horizontal Int 135° Corner Tray New Build 50-74mm - With Polystrip	Black	1	3 -5 Working Days	2013P/50	36
System 2000 Horizontal Int 135° Corner Tray New Build 75-99mm - With Polystrip	Black	1	3 -5 Working Days	2013P/75	36
System 2000 Horizontal Int 135° Corner Tray New Build 100-125mm - With Polystrip	Black	1	3 -5 Working Days	2013P/100	36
Lintel Stop End Splay Angle 90° Black	Black	10	Next Working Day	LS01	43

For Ambi-Soakers please see Roofline section

Cavity Closers, Barriers & Stop Socks

Description	Colour	Quantity	Lead Time	Product Code	Page No.
Thermo-Loc Platinum Multi Cavity Closer 50-100mm Cav 2.4m	Grey	10	Next Working Day	CC2.4PPS/MULTI100	49
Thermo-Loc Platinum Multi Cavity Closer 100-150mm Cav 2.4m	Grey	10	Next Working Day	CC2.4PPS/MULTI150	49
Thermo-Loc Platinum+ Cavity Closer 50mm Cav 2.4m	Grey	10	Next Working Day	PP2.4/50	50
Thermo-Loc Platinum+ Cavity Closer 75mm Cav 2.4m	Grey	10	Next Working Day	PP2.4/75	50
Thermo-Loc Platinum+ Cavity Closer 90mm Cav 2.4m	Grey	10	Next Working Day	PP2.4/90	50
Thermo-Loc Platinum+ Cavity Closer 100mm Cav 2.4m	Grey	10	Next Working Day	PP2.4/100	50
Thermo-Loc Platinum+ Multi Cavity Closer 50-100mm Cav 2.4m	Grey	10	Next Working Day	PP2.4/100MULTI	50
Thermo-Loc Platinum+ Cavity Closer 120mm Cav 2.4m	Grey	10	3 Working Day	PP2.4/120	50
Thermo-Loc Platinum+ Cavity Closer 125mm Cav 2.4m	Grey	10	Next Working Day	PP2.4/125	50
Thermo-Loc Platinum+ Cavity Closer 130mm Cav 2.4m	Grey	10	3 Working Day	PP2.4/130	50
Thermo-Loc Platinum+ Cavity Closer 150mm Cav 2.4m	Grey	10	Next Working Day	PP2.4/150	50
Thermo-Loc Platinum+ CR Multi Cavity Closer 50-100mm Cav 2.4m	Grey	10	3 Working Days	PP2.4/CR100MULTI	50
Thermo-Loc Platinum+ FX Cavity Closer 50mm Cav 2.4m	Grey	10	Next Working Day	FX2.4/50	52
Thermo-Loc Platinum+ FX Cavity Closer 75mm Cav 2.4m	Grey	10	Next Working Day	FX2.4/75	52

CONSTRUCTION ACCESSORIES

CAVITY TRAYS

CAVITY CLOSERS

ACCESS PRODUCTS

ADAPT-AIR

RAD-SEAL

ROOFLINE

THROUGH-WALL VENTILATION

TOP HATS, GAS BARRIERS & DPC

METER BOXES

Description	Colour	Quantity	Lead Time	Product Code	Page No.
Thermo-Loc Platinum+ FX Cavity Closer 90mm Cav 2.4m	Grey	10	Next Working Day	FX2.4/90	52
Thermo-Loc Platinum+ FX Cavity Closer 100mm Cav 2.4m	Grey	10	Next Working Day	FX2.4/100	52
Thermo-Loc Platinum+ FX Multi Cavity Closer 50-100mm Cav 2.4m	Grey	10	Next Working Day	FX2.4/100MULTI	52
Thermo-Loc Platinum+ FX Cavity Closer 120mm Cav 2.4m	Grey	10	3 Working Days	FX2.4/120	52
Thermo-Loc Platinum+ FX Cavity Closer 125mm Cav 2.4m	Grey	10	Next Working Day	FX2.4/125	52
Thermo-Loc Platinum+ FX Cavity Closer 130mm Cav 2.4m	Grey	10	3 Working Days	FX2.4/130	52
Thermo-Loc Platinum+ FX Cavity Closer 150mm Cav 2.4m	Grey	10	Next Working Day	FX2.4/150	52
Thermo-Loc Platinum+ FX Cavity Closer CR 50mm Cav 2.4m	Grey	10	3 Working Days	FX2.4/CR50	52
Thermo-Loc Platinum+ FX Cavity Closer CR 100mm Cav 2.4m	Grey	10	3 Working Days	FX2.4/CR100	52
Thermo-Loc Platinum+ FX Multi Cavity Closer CR 50-100mm Cav 2.4m	Grey	10	3 Working Days	FX2.4/CR100MULTI	52
Thermo-Loc Platinum+ FX Cavity Closer CR 125mm Cav 2.4m	Grey	10	3 Working Days	FX2.4/CR125	52
Thermo-Loc Platinum+ FX Cavity Closer CR 150mm Cav 2.4m	Grey	10	3 Working Days	FX2.4/CR150	52

Description	Colour	Quantity	Lead Time	Product Code	Page No.
Thermo-Loc FR30 Cavity Closer 50mm Cav 2.4m	Blue	10	Next Working Day	CC2.4FR/50	54
Thermo-Loc FR30 Cavity Closer 65mm Cav 2.4m	Blue	10	Next Working Day	CC2.4FR/65	54
Thermo-Loc FR30 Cavity Closer 75mm Cav 2.4m	Blue	10	Next Working Day	CC2.4FR/75	54
Thermo-Loc FR30 Cavity Closer 90mm Cav 2.4m	Blue	10	Next Working Day	CC2.4FR/90	54
Thermo-Loc FR30 Cavity Closer 100mm Cav 2.4m	Blue	5	Next Working Day	CC2.4FR/100	54
Thermo-Loc FR30 Cavity Closer 125mm Cav 2.4m	Blue	5	Next Working Day	CC2.4FR/125	54
Thermo-Loc FR30 Cavity Closer 150mm Cav 2.4m	Blue	3	Next Working Day	CC2.4FR/150	54
Thermo-Loc Cavity Closer Fixing Ties Pack of 100	White	100	Next Working Day	CCFIX	54

FR30 - NB. Non standard cavity sizes upto 300mm available to special order

NON STANDARD & SPECIAL LEAD TIMES

- Orders for non standard and special sizes upto 50 pieces received before 12pm - Next working day.
- Orders received after 12pm will be despatched the following working day.
- Orders for non standard and specials sizes over 50 pieces - 3 working days.

Description	Colour	Quantity	Lead Time	Product Code	Page No.
Thermo-Loc FR60 Cavity Closer 50mm Cav x 2.4m	Red	5	Next Working Day	FR60/50	56
Thermo-Loc FR60 Cavity Closer 100mm Cav x 2.4m	Red	5	Next Working Day	FR60/100	56
Thermo-Loc FR60 Cavity Closer 125mm Cav x 2.4m	Red	5	Next Working Day	FR60/125	56
Thermo-Loc FR60 Cavity Closer 150mm Cav x 2.4m	Red	5	Next Working Day	FR60/150	56
Thermo-Loc FR60 Cavity Closer CR 50mm Cav x 2.4m	Red	5	3 Working Days	FR60/CR50	56
Thermo-Loc FR60 Cavity Closer CR 65mm Cav x 2.4m	Red	5	3 Working Days	FR60/CR65	56
Thermo-Loc FR60 Cavity Closer CR 75mm Cav x 2.4m	Red	5	3 Working Days	FR60/CR75	56
Thermo-Loc FR60 Cavity Closer CR 90mm Cav x 2.4m	Red	5	3 Working Days	FR60/CR90	56
Thermo-Loc FR60 Cavity Closer CR 100mm Cav x 2.4m	Red	5	3 Working Days	FR60/CR100	56
Thermo-Loc FR60 Cavity Closer CR 125mm Cav x 2.4m	Red	5	3 Working Days	FR60/CR125	56
Thermo-Loc FR60 Cavity Closer CR 150mm Cav x 2.4m	Red	5	3 Working Days	FR60/CR150	56
Thermo-Loc Cavity Closer Fixing Ties Pack of 100	White	100	Next Working Day	CCFIX	56

FR60 - NB. Non standard cavity sizes upto 300mm available to special order

NON STANDARD & SPECIAL LEAD TIMES

- Orders for non standard and special sizes upto 50 pieces received before 12pm - Next working day.
- Orders received after 12pm will be despatched the following working day.
- Orders for non standard and specials sizes over 50 pieces - 3 working days.

Description	Colour	Quantity	Lead Time	Product Code	Page No.
Thermo-Loc FR60 + Cavity Closer 175mm Cav x 2.4m	Red	2	Variable (see below)	FR60/175	58
Thermo-Loc FR60 + Cavity Closer 200mm Cav x 2.4m	Red	2	Variable (see below)	FR60/200	58
Thermo-Loc FR60 + Cavity Closer 225mm Cav x 2.4m	Red	2	Variable (see below)	FR60/225	58
Thermo-Loc FR60 + Cavity Closer 250mm Cav x 2.4m	Red	2	Variable (see below)	FR60/250	58
Thermo-Loc FR60 + Cavity Closer 275mm Cav x 2.4m	Red	2	Variable (see below)	FR60/275	58
Thermo-Loc FR60 + Cavity Closer 300mm Cav x 2.4m	Red	2	Variable (see below)	FR60/300	58
Thermo-Loc FR60 + Fixing Flange - 4 Pack	Silver	4	Next Working Day	3322	58

FR60+ - NB. Non standard cavity sizes upto 300mm available to special order

NON STANDARD & SPECIAL LEAD TIMES

- Orders for FR60+ sizes upto 50 pieces received before 12pm - Next working day.
- Orders received after 12pm will be despatched the following working day.
- Orders for FR60+ sizes over 50 pieces - 3 working days.

Description	Colour	Quantity	Lead Time	Product Code	Page No.
FRstop Fire-Rated Cavity Stop Sock Masonry 50mm Cav x 1.2m	Yellow	20	Next Working Day	FRSTOP50	60
FRstop Fire-Rated Cavity Stop Sock Masonry 75mm Cav x 1.2m	Blue	18	Next Working Day	FRSTOP75	60
FRstop Fire-Rated Cavity Stop Sock Masonry 85mm Cav x 1.2m	Blue	1	Next Working Day	FRSTOP85	60
FRstop Fire-Rated Cavity Stop Sock Masonry 90mm Cav x 1.2m	Blue	1	Next Working Day	FRSTOP90	60
FRstop Fire-Rated Cavity Stop Sock Masonry 100mm Cav x 1.2m	Blue	1	Next Working Day	FRSTOP100	60
FRstop Fire-Rated Cavity Stop Sock Masonry 115mm Cav x 1.2m	Green	1	Next Working Day	FRSTOP115	60
FRstop Fire-Rated Cavity Stop Sock Masonry 125mm Cav x 1.2m	Green	1	Next Working Day	FRSTOP125	60
FRstop Fire-Rated Cavity Stop Sock Masonry 150mm Cav x 1.2m	Red	1	Next Working Day	FRSTOP150	60

Access Products

Description	Colour	Quantity	Lead Time	Product Code	Page No.
Plastic Push Up Loft Access Door 562x665mm	White	1	Next Working Day	1168	62
0.25UV Plastic Drop-in Loft Access Door 562x665mm	White	1	Next Working Day	1168/25	62
0.35UV Plastic Drop-in Loft Access Door 562x665mm	White	1	Next Working Day	1168/35	62
Plastic Hinged Drop Down Loft Access Door 562x662mm	White	1	Next Working Day	1169	63
Plastic Hinged Drop Down Loft Access Door 562x662mm Keylock	White	1	Next Working Day	1169KL	63
0.25UV Plastic Hinged Drop Down Loft Access Door 562x662mm	White	1	Next Working Day	1169/25	63
0.25UV Plastic Hinged Drop Down Loft Access Door 562x662mm Keylock	White	1	Next Working Day	1169/25KL	63
0.35 UV Plastic Hinged Loft Access Door 562x665mm	White	1	Next Working Day	1169/35	63
0.35UV Plastic Hinged Drop Down Loft Access Door 562x662mm Keylock	White	1	Next Working Day	1169/35KL	63
Z-Series Loft Door Fire Rated 550x550mm	White	1	Next Working Day	Z8001	64
Z-Series Loft Door Fire Rated 555x800mm	White	1	Next Working Day	Z8002	64
Z-Series Loft Door Fire Rated 542x630mm - 1161	White	1	Next Working Day	Z8003	64
Z-Series Loft Door Fire Rated 542x745mm - 1160	White	1	Next Working Day	Z8004	64
Z-Series Loft Door Fire Rated 600x600mm	White	1	Next Working Day	Z8005	64
Z-Series Loft Door Fire Rated 600x900mm	White	1	Next Working Day	Z8006	64
Z-Series Loft Door Fire Rated 900x600mm	White	1	Next Working Day	Z8007	64
Z-Series Loft Door Fire Rated 1200x600mm	White	1	Next Working Day	Z8008	64
Z-Series Loft Door Fire Rated 0.35 U Value 550x550mm	White	1	Next Working Day	Z9001	64
Z-Series Loft Door Fire Rated 0.35 U Value 555x800mm	White	1	Next Working Day	Z9002	64
Z-Series Loft Door Fire Rated 0.35 U V 542x630mm -1161/35	White	1	Next Working Day	Z9003	64
Z-Series Loft Door Fire Rated 0.35 U Val 542x745mm -1160/35	White	1	Next Working Day	Z9004	64
Z-Series Loft Door Fire Rated 0.35 U Value 600x600mm	White	1	Next Working Day	Z9005	64
Z-Series Loft Door Fire Rated 0.35 U Value 600x900mm	White	1	Next Working Day	Z9006	64
Z-Series Loft Door Fire Rated 0.35 U Value 900x600mm	White	1	Next Working Day	Z9007	64
Z-Series Loft Door Fire Rated 0.35 U Value 1200x600mm	White	1	Next Working Day	Z9008	64
Z-Series Loft Door Fire Rated Key Lock 550x550mm	White	1	Next Working Day	ZKL8001	64
Z-Series Loft Door Fire Rated Key Lock 555x800mm	White	1	Next Working Day	ZKL8002	64
Z-Series Loft Door Fire Rated Key Lock 542x630mm - 1161/KL	White	1	Next Working Day	ZKL8003	64
Z-Series Loft Door Fire Rated Key Lock 542x745mm - 1160/KL	White	1	Next Working Day	ZKL8004	64
Z-Series Loft Door Fire Rated Key Lock 600x600mm	White	1	Next Working Day	ZKL8005	64
Z-Series Loft Door Fire Rated Key Lock 600x900mm	White	1	Next Working Day	ZKL8006	64
Z-Series Loft Door Fire Rated Key Lock 900x600mm	White	1	Next Working Day	ZKL8007	64
Z-Series Loft Door Fire Rated Key Lock 1200x600mm	White	1	Next Working Day	ZKL8008	64
Z-Series Loft Door FR Keylock 0.35 U Value 550x550mm	White	1	Next Working Day	ZKL9001	64
Z-Series Loft Door FR Keylock 0.35 U Value 555x800mm	White	1	Next Working Day	ZKL9002	64
Z-Series Loft Door FR Keylock 0.35 U 542x630 - 1161/35KL	White	1	Next Working Day	ZKL9003	64
Z-Series Loft Door FR Keylock 0.35 U V 542x745 - 1160/35KL	White	1	Next Working Day	ZKL9004	64
Z-Series Loft Door FR Keylock 0.35 U Value 600x600mm	White	1	Next Working Day	ZKL9005	64
Z-Series Loft Door FR Keylock 0.35 U Value 600x900mm	White	1	Next Working Day	ZKL9006	64
Z-Series Loft Door FR Keylock 0.35 U Value 900x600mm	White	1	Next Working Day	ZKL9007	64
Z-Series Loft Door FR Keylock 0.35 U Value 1200x600mm	White	1	Next Working Day	ZKL9008	64
Loft-Loc Square T-key Loft Door Metal Pole 600mm	Silver	1	Next Working Day	Z1162	68
Loft-Loc Slotted Loft Door Metal Pole 600mm	Silver	1	Next Working Day	Z1170	68
Plastic Access Panel 115x165mm Clip Fit	White	1	Next Working Day	AP110	70
Plastic Access Panel 155x235mm Hinged	White	1	Next Working Day	AP150	70
Plastic Access Panel 155x235mm Hinged Key Lock	White	1	Next Working Day	AP150KL	70
Plastic Access Panel 205x205mm Clip Fit	White	1	Next Working Day	AP200	70
Plastic Access Panel 305x305mm Hinged	White	1	Next Working Day	AP300	70
Plastic Access Panel 305x305mm Hinged Key Lock	White	1	Next Working Day	AP300KL	70
Plastic Access Panel 470x470mm Hinged	White	1	Next Working Day	AP450	70
Plastic Access Panel 470x470mm Hinged Key Lock	White	1	Next Working Day	AP450KL	70
Plastic Air Tight Access Panel 115x165mm	White	1	Next Working Day	AP110AT	71
Plastic Air Tight Access Panel 155x235mm	White	1	Next Working Day	AP150AT	71
Plastic Air Tight Access Panel 205x205mm	White	1	Next Working Day	AP200AT	71
Plastic Air Tight Access Panel 305x305mm	White	1	Next Working Day	AP300AT	71
Plastic Air Tight Access Panel 470x470mm	White	1	Next Working Day	AP450AT	71
Plastic Key Hole Plug	White	1	Next Working Day	KEYPLUG	71
Z-Series Metal Access Panel 150x150mm	White	1	Next Working Day	Z2001	72
Z-Series Metal Access Panel 150x230mm	White	1	Next Working Day	Z2002	72
Z-Series Metal Access Panel 200x200mm	White	1	Next Working Day	Z2003	72
Z-Series Metal Access Panel 300x300mm	White	1	Next Working Day	Z2004	72
Z-Series Metal Access Panel 350x350mm	White	1	Next Working Day	Z2005	72
Z-Series Metal Access Panel 450x450mm	White	1	Next Working Day	Z2006	72
Z-Series Metal Access Panel 550x550mm	White	1	Next Working Day	Z2007	72
Z-Series Metal Access Panel 600x300mm	White	1	Next Working Day	Z2008	72
Z-Series Metal Access Panel 600x600mm	White	1	Next Working Day	Z2009	72

CONSTRUCTION
ACCESSORIES

CAVITY
TRAYS

CAVITY
CLOSERS

ACCESS
PRODUCTS

ADAPT-AIR

RAD-SEAL

ROOFLINE

THROUGH-WALL
VENTILATION

TOP HATS, GAS
BARRIERS & DPC

METER
BOXES

Description	Colour	Quantity	Lead Time	Product Code	Page No.
1 Hour Fire-Rated Metal Access Panel 150x150mm	White	1	Next Working Day	APC150x150CR	73
1 Hour Fire-Rated Metal Access Panel 150x230mm	White	1	Next Working Day	APC150x230CR	73
1 Hour Fire-Rated Metal Access Panel 200x200mm	White	1	Next Working Day	APC200x200CR	73
1 Hour Fire-Rated Metal Access Panel 300x300mm	White	1	Next Working Day	APC300x300CR	73
1 Hour Fire-Rated Metal Access Panel 450x450mm	White	1	Next Working Day	APC450x450CR	73
1 Hour Fire-Rated Metal Access Panel 550x550mm	White	1	Next Working Day	APC550x550CR	73
1 Hour Fire-Rated Metal Access Panel 600x600mm	White	1	Next Working Day	APC600x600CR	73
1 Hour Fire-Rated Metal Access Panel 150x150mm - Key Lock	White	1	Next Working Day	APC150x150CRKL	73
1 Hour Fire-Rated Metal Access Panel 150x230mm - Key Lock	White	1	Next Working Day	APC150x230CRKL	73
1 Hour Fire-Rated Metal Access Panel 200x200mm - Key Lock	White	1	Next Working Day	APC200x200CRKL	73
1 Hour Fire-Rated Metal Access Panel 300x300mm - Key Lock	White	1	Next Working Day	APC300x300CRKL	73
1 Hour Fire-Rated Metal Access Panel 450x450mm - Key Lock	White	1	Next Working Day	APC450x450CRKL	73
1 Hour Fire-Rated Metal Access Panel 550x550mm - Key Lock	White	1	Next Working Day	APC550x550CRKL	73
1 Hour Fire-Rated Metal Access Panel 600x600mm - Key Lock	White	1	Next Working Day	APC600x600CRKL	73

Adapt-Air

Description	Colour	Quantity	Lead Time	Product Code	Page No.
Adapt-Air Single Airbrick 100x54x450mm Black	Black	1	Next Working Day	6510BL	75
Adapt-Air Single Airbrick 100x54x450mm Brown	Brown	1	Next Working Day	6510BR	75
Adapt-Air Single Airbrick 100x54x450mm Buff	Buff	1	Next Working Day	6510BU	75
Adapt-Air Single Airbrick 100x54x450mm Grey	Grey	1	Next Working Day	6510GR	75
Adapt-Air Single Airbrick 100x54x450mm Terracotta	Terracotta	1	Next Working Day	6510TE	75
Adapt-Air Single Airbrick 100x54x450mm White	White	1	Next Working Day	6510WH	75
Adapt-Air Single Airbrick 100x430mm Black	Black	1	Next Working Day	6520BL	75
Adapt-Air Single Airbrick 100x430mm Brown	Brown	1	Next Working Day	6520BR	75
Adapt-Air Single Airbrick 100x430mm Buff	Buff	1	Next Working Day	6520BU	75
Adapt-Air Single Airbrick 100x430mm Grey	Grey	1	Next Working Day	6520GR	75
Adapt-Air Single Airbrick 100x430mm Terracotta	Terracotta	1	Next Working Day	6520TE	75
Adapt-Air Single Airbrick 110x450mm Buff	Buff	1	Next Working Day	3511BU	75
Adapt-Air Single Airbrick 110x450mm Terracotta	Terracotta	1	Next Working Day	3511TE	75
Adapt-Air Single Airbrick 100x330mm Black	Black	1	Next Working Day	6500BL	75
Adapt-Air Single Airbrick 100x330mm Brown	Brown	1	Next Working Day	6500BR	75
Adapt-Air Single Airbrick 100x330mm Buff	Buff	1	Next Working Day	6500BU	75
Adapt-Air Single Airbrick 100x330mm Grey	Grey	1	Next Working Day	6500GR	75
Adapt-Air Single Airbrick 100x330mm Terracotta	Terracotta	1	Next Working Day	6500TE	75
Adapt-Air Single Airbrick 100x330mm White	White	1	Next Working Day	6500WH	75
Adapt-Air Double Airbrick 330x125mm Black	Black	1	Next Working Day	6512BL	75
Adapt-Air Double Airbrick 330x125mm Brown	Brown	1	Next Working Day	6512BR	75
Adapt-Air Double Airbrick 330x125mm Buff	Buff	1	Next Working Day	6512BU	75
Adapt-Air Double Airbrick 330x125mm Grey	Grey	1	Next Working Day	6512GR	75
Adapt-Air Double Airbrick 330x125mm Terracotta	Terracotta	1	Next Working Day	6512TE	75
Adapt-Air Double Airbrick 330x125mm White	White	1	Next Working Day	6512WH	75
Adapt-Air Double Airbrick 430x125mm Black	Black	1	Next Working Day	6525BL	75
Adapt-Air Double Airbrick 430x125mm Brown	Brown	1	Next Working Day	6525BR	75
Adapt-Air Double Airbrick 430x125mm Buff	Buff	1	Next Working Day	6525BU	75
Adapt-Air Double Airbrick 430x125mm Grey	Grey	1	Next Working Day	6525GR	75
Adapt-Air Double Airbrick 430x125mm Terracotta	Terracotta	1	Next Working Day	6525TE	75
Adapt-Air Double Airbrick 430x125mm White	White	1	Next Working Day	6525WH	75
Adapt-Air Double Airbrick 330x150mm Black	Black	1	Next Working Day	6515BL	75
Adapt-Air Double Airbrick 330x150mm Brown	Brown	1	Next Working Day	6515BR	75
Adapt-Air Double Airbrick 330x150mm Buff	Buff	1	Next Working Day	6515BU	75
Adapt-Air Double Airbrick 330x150mm Grey	Grey	1	Next Working Day	6515GR	75
Adapt-Air Double Airbrick 330x150mm Terracotta	Terracotta	1	Next Working Day	6515TE	75
Adapt-Air Double Airbrick 330x150mm White	White	1	Next Working Day	6515WH	75
Adapt-Air Double Airbrick 430x150mm Black	Black	1	Next Working Day	6550BL	75
Adapt-Air Double Airbrick 430x150mm Brown	Brown	1	Next Working Day	6550BR	75
Adapt-Air Double Airbrick 430x150mm Buff	Buff	1	Next Working Day	6550BU	75
Adapt-Air Double Airbrick 430x150mm Grey	Grey	1	Next Working Day	6550GR	75
Adapt-Air Double Airbrick 430x150mm Terracotta	Terracotta	1	Next Working Day	6550TE	75
Adapt-Air Double Airbrick 430x150mm White	White	1	Next working day	6550WH	75

Rad-Seal

Description	Colour	Quantity	Lead Time	Product Code	Page No.
Rad-Seal 15 Face-Fix - Radiator Pipe Guide and Seal (Face-fix)	White	20	Next Working Day	2222	79
Rad-Seal Face-Fix - Radiator Pipe Guide and Seal (Face-fix)	White	20	Next Working Day	2221	80
Rad-Seal Recessed - Radiator Pipe Guide and Seal (Recessed)	White	10	Next Working Day	1115	81

Roofline

Description	Colour	Quantity	Lead Time	Product Code	Page No.
Push-In Round Soffit Vent 70mm Dia.	Grey	10	Next Working Day	1139	84
Push-In Round Soffit Vent 70mm Dia.	White	10	Next Working Day	1140	84
Push-In Round Soffit Vent 70mm Dia.	Black	10	Next Working Day	1141	84
Push-In Round Soffit Vent 70mm Dia.	Brown	10	Next Working Day	1142	84
Roof Soffit Strip Vent Type C 10mm Airflow 2.4m	Black	10	Next Working Day	1137BL	85
Roof Soffit Strip Vent Type C 10mm Airflow 2.4m	Brown	10	Next Working Day	1137BR	85
Roof Soffit Strip Vent Type C 10mm Airflow 2.4m	White	10	Next Working Day	1137WH	85
Roof Soffit Strip Vent Type C 25mm Airflow 2.4m	Brown	10	Next Working Day	1138BR	85
Roof Soffit Strip Vent Type C 25mm Airflow 2.4m	White	10	Next Working Day	1138WH	85
Corbel Roof Eaves Vent 10mm Airflow 2.4m	Black	10	Next Working Day	3012	86
Over Fascia Eaves Vent Strip 10mm Airflow 300mm	Black	10	Next Working Day	3011BL	87
Over Fascia Eaves Vent Strip 10mm Airflow 300mm	White	10	Next Working Day	3011WH	87
Over Fascia Eaves Vent Strip 25mm Airflow 300mm	Black	10	Next Working Day	3011/25BL	87
Over Fascia Eaves Vent Strip 25mm Airflow 300mm	White	10	Next Working Day	3011/25W	87
Over Fascia Vent Strip 10mm Airflow 1m	Black	25	Next Working Day	OF1BL	88
Over Fascia Vent Strip 25mm Airflow 1m	Black	20	Next Working Day	OF2BL	88
Over Fascia Eaves Vent System 10mm Airflow 1m	Black	20	Next Working Day	3014	89
Over Fascia Eaves Vent System with Comb Filler 10mm Airflow 1m	Black	10	Next Working Day	3014C	89
Rafter Roll 300mm x 6m	Black	10	Next Working Day	1121	90
Rafter Roll 400mm x 6m	Black	12	Next Working Day	1171	90
Rafter Roll 600mm x 6m	Black	5	Next Working Day	1131	90
Rafter Roll 800mm x 6m	Black	6	Next Working Day	1151	90
3 in 1 Eaves Vent Pack 10mm Airflow 6m (300mm Roll Out Rafter Tray)	Black	10	Next Working Day	EVP6	91
3 in 1 Eaves Vent Pack 25mm airflow 6m (300mm Roll Out Rafter Tray)	Black	10	Next Working Day	EVP6/25	91
3 in 1 Eaves Vent Pack 25mm airflow 6m (600mm Roll Out Rafter Tray)	Black	10	Next Working Day	EVP6/25600	91
3 in 1 Eaves Vent Pack 10mm airflow 6m (600mm Roll Out Rafter Tray)	Black	10	Next Working Day	EVP6/600	91
Felt Support Tray 600mm	Black	20	Next Working Day	1128	92
Felt Support Tray 1500mm	Black	10	Next Working Day	3017	92
Eaves Comb Filler	Black	50	Next Working Day	1136	93
Lap Vent	Off-white	10	Next Working Day	5560	94
6m Roll Out Dry Fix Ridge Kit	Black	1	Next Working Day	54700	96
13x Ridge Unions & 26x Ridge Clips	Black	13 & 26	Next Working Day	54618	96
13x Fixing Screws & Clamping Plates	N/A	13	Next Working Day	54626	96
3m Integrated Dry Ridge Kit	Black	1	Next Working Day	53700	97
6m Integrated Dry Ridge Kit	Black	1	Next Working Day	54703	97
10m Integrated Dry Ridge Kit	Black	1	Next Working Day	51700	97
6m Roll Out Dry Fix Clay Ridge Kit	Black	1	Next Working Day	54713	98
20 x ridge unions & 40 x ridge clips	Black	1	Next Working Day	54715	98
20 x fixing screws & clamping plates	Silver	1	Next Working Day	54716	98
6m Roll Out Dry Fix Hip Kit	Black	1	Next Working Day	54710	99
6x Dry Fix Hip Tray Pack	Black	6	Next Working Day	44623	99
Hip Accessory Kit	Black	1	Next Working Day	44629	100
Universal Dry Fix Angled Ridge End Cap	Grey	10	Next Working Day	99109	102
Universal Dry Fix Angled Ridge End Cap	Brown	10	Next Working Day	99108	102
Universal Dry Fix Angled Ridge End Cap	Black	10	Next Working Day	99107	102
Universal Dry Fix Angled Ridge End Cap	Terracotta	10	Next Working Day	99110	102
Universal Dry Fix Angled Ridge End Cap	Red	10	Next Working Day	99183	102
Universal Dry Fix Round Ridge End Cap	Grey	10	Next Working Day	99113	102
Universal Dry Fix Round Ridge End Cap	Brown	10	Next Working Day	99112	102
Universal Dry Fix Round Ridge End Cap	Black	10	Next Working Day	99136	102
Universal Dry Fix Round Ridge End Cap	Terracotta	10	Next Working Day	99114	102
Universal Dry Fix Round Ridge End Cap	Red	10	Next Working Day	99184	102
Ambi-Verge Universal Dry Fix Verge Piece	Grey	20	Next Working Day	99141	102
Ambi-Verge Universal Dry Fix Verge Piece	Brown	20	Next Working Day	99142	102
Ambi-Verge Universal Dry Fix Verge Piece	Black	20	Next Working Day	99143	102
Ambi-Verge Universal Dry Fix Verge Piece	Terracotta	20	Next Working Day	99144	102
Ambi-Verge Eaves Starter	Grey	1	Next Working Day	99153	102
Ambi-Verge Eaves Starter	Brown	1	Next Working Day	99155	102
Ambi-Verge Eaves Starter	Black	1	Next Working Day	99154	102
Ambi-Verge Eaves Starter	Terracotta	1	Next Working Day	99156	102
Dry Verge Profiled Tile End Grain Batten Bracket	Silver	20	Next Working Day	99124	104
Dry Fix Verge for Profiled Tile Eaves Closer L&R Pair	Grey	1+1	Next Working Day	99126	104
Dry Fix Verge for Profiled Tile Eaves Closer L&R Pair	Brown	1+1	Next Working Day	99125	104
Dry Fix Verge for Profiled Tile Eaves Closer L&R Pair	Black	1+1	Next Working Day	99130	104
Dry Fix Verge for Profiled Tile Eaves Closer L&R Pair	Terracotta	1+1	Next Working Day	99127	104
Dry Fix Verge for Profiled Tile Left Hand Unit	Grey	20	Next Working Day	99121	104

CONSTRUCTION
ACCESSORIES

CAVITY
TRAYS

CAVITY
CLOSERS

ACCESS
PRODUCTS

ADAPT-AIR

RAD-SEAL

ROOFLINE

THROUGH-WALL
VENTILATION

TOP HATS, GAS
BARRIERS & DPC

METER
BOXES

Roofline (continued)

Description	Colour	Quantity	Lead Time	Product Code	Page No.
Dry Fix Verge for Profiled Tile Left Hand Unit	Brown	20	Next Working Day	99120	104
Dry Fix Verge for Profiled Tile Left Hand Unit	Black	20	Next Working Day	99138	104
Dry Fix Verge for Profiled Tile Left Hand Unit	Terracotta	20	Next Working Day	99122	104
Dry Fix Verge for Profiled Tile Right Hand Unit	Grey	20	Next Working Day	99117	104
Dry Fix Verge for Profiled Tile Right Hand Unit	Brown	20	Next Working Day	99116	104
Dry Fix Verge for Profiled Tile Right Hand Unit	Black	20	Next Working Day	99137	104
Dry Fix Verge for Profiled Tile Right Hand Unit	Terracotta	20	Next Working Day	99118	104
Interlocking Plain Tile Dry Fix Verge	Black	40	Next Working Day	99173	106
Interlocking Plain Tile Dry Fix Verge	Grey	40	Next Working Day	99174	106
Interlocking Plain Tile Dry Fix Verge	Terracotta	40	Next Working Day	99175	106
Interlocking Plain Tile Dry Fix Verge	Brown	40	Next Working Day	99176	106
Interlocking Plain Tile Dry Fix Verge	Red	40	Next Working Day	99182	106
Interlocking Plain Tile Verge starter	Black	10	Next Working Day	99177	106
Interlocking Plain Tile Verge starter	Grey	10	Next Working Day	99178	106
Interlocking Plain Tile Verge starter	Terracotta	10	Next Working Day	99179	106
Interlocking Plain Tile Verge starter	Brown	10	Next Working Day	99180	106
Interlocking Plain Tile Verge starter	Red	10	Next Working Day	99181	106
Dry Verge Profiled Tile End Grain Batten Bracket (optional)	Silver	20	Next Working Day	99124	106
Thin Leading Edge Verge (LH)	Black	20	Next Working Day	99157	108
Thin Leading Edge Verge (LH)	Grey	20	Next Working Day	99158	108
Thin Leading Edge Verge (LH)	Terracotta	20	Next Working Day	99159	108
Thin Leading Edge Verge (LH)	Brown	20	Next Working Day	99160	108
Thin Leading Edge Verge (RH)	Black	20	Next Working Day	99161	108
Thin Leading Edge Verge (RH)	Grey	20	Next Working Day	99162	108
Thin Leading Edge Verge (RH)	Terracotta	20	Next Working Day	99163	108
Thin Leading Edge Verge (RH)	Brown	20	Next Working Day	99164	108
Thin Leading Edge Verge Starter (LH)	Black	10	Next Working Day	99165	108
Thin Leading Edge Verge Starter (LH)	Grey	10	Next Working Day	99166	108
Thin Leading Edge Verge Starter (LH)	Terracotta	10	Next Working Day	99167	108
Thin Leading Edge Verge Starter (LH)	Brown	10	Next Working Day	99168	108
Thin Leading Edge Verge Starter (RH)	Black	10	Next Working Day	99169	108
Thin Leading Edge Verge Starter (RH)	Grey	10	Next Working Day	99170	108
Thin Leading Edge Verge Starter (RH)	Terracotta	10	Next Working Day	99171	108
Thin Leading Edge Verge Starter (RH)	Brown	10	Next Working Day	99172	108
Dry Verge Profiled Tile End Grain Batten Bracket (optional)	Silver	20	Next Working Day	99124	108
New Build Dry Fix Continuous Verge for Slate / Flat Tile	Grey	4	Next Working Day	66101	110
Refurb Dry Fix Continuous Verge for Slate / Flat Tile	Grey	4	Next Working Day	66105	110
Dry Fix Continuous Verge Eaves Closer L&R Pair	Grey	1+1	Next Working Day	66117	110
Dry Fix Continuous Dry Verge for Slate / Flat Tile Angled Ridge Cap	Grey	1	Next Working Day	66120	110
Dry Fix Continuous Dry Verge for Slate / Flat Tile Joint Union Pair	Grey	1	Next Working Day	66124	110
Ambi-Soaker - Plain	Black	50	Next Working Day	AS-PLAIN	112
Ambi-Soaker - Interlocking Plain	Black	40	Next Working Day	AS-INTPLAIN	113
Ambi-Soaker - Slate	Black	50	Next Working Day	AS-SLATE	114
Ambi-Soaker - Thin Leading Edge	Grey	50	Next Working Day	AS-TLE	115
Ambi-Soaker - Flat	Grey	30	Next Working Day	AS-FLAT	116
PbFree Lead-free Flashing 150mm	Grey	1	Next Working Day	LF150	117
PbFree Lead-free Flashing 300mm	Grey	1	Next Working Day	LF300	117
PbFree Lead-free Flashing 450mm	Grey	1	Next Working Day	LF450	117
MemBreathe 115gsm Breathable Membrane 1m	Grey	1	Next Working Day	MEM11550	118
MemBreathe 115gsm Breathable Membrane 1.5m	Grey	1	Next Working Day	MEM11575	118
MemBreathe 135gsm Breathable Membrane 1m	Blue	1	Next Working Day	MEM13550	119
MemBreathe 135gsm Breathable Membrane 1.5m	Blue	1	Next Working Day	MEM13575	119
MemBreathe 165gsm Breathable Membrane 1m	Green	1	Next Working Day	MEM16550	120
MemBreathe 165gsm Breathable Membrane 1.5m	Green	1	Next Working Day	MEM16575	120
Castellated Roof Tile Vent	Terracotta	1	Next Working Day	RTV-CTE	126
Castellated Roof Tile Vent	Brown	1	Next Working Day	RTV-CBR	126
Castellated Roof Tile Vent	Grey	1	Next Working Day	RTV-CGR	126
Castellated Roof Tile Vent	Red	1	Next Working Day	RTV-CRD	126
Double Pantile Roof Tile Vent	Terracotta	1	Next Working Day	RTV-DPTE	127
Double Pantile Roof Tile Vent	Brown	1	Next Working Day	RTV-DPBR	127
Double Pantile Roof Tile Vent	Grey	1	Next Working Day	RTV-DPGR	127
Double Pantile Roof Tile Vent	Red	1	Next Working Day	RTV-DPRD	127
Double Roman Roof Tile Vent	Terracotta	1	Next Working Day	RTV-DRTE	128
Double Roman Roof Tile Vent	Brown	1	Next Working Day	RTV-DRBR	128
Double Roman Roof Tile Vent	Grey	1	Next Working Day	RTV-DRGR	128
Double Roman Roof Tile Vent	Red	1	Next Working Day	RTV-DRRD	128

Description	Colour	Quantity	Lead Time	Product Code	Page No.
Flat Edge Roof Tile Vent	Terracotta	1	Next Working Day	RTV-FETE	129
Flat Edge Roof Tile Vent	Brown	1	Next Working Day	RTV-FEBR	129
Flat Edge Roof Tile Vent	Grey	1	Next Working Day	RTV-FEGR	129
Flat Edge Roof Tile Vent	Red	1	Next Working Day	RTV-FERD	129
Flat Edge Roof Tile Vent	Black	1	Next Working Day	RTV-FEBL	129
Non-Profile Roof Tile Vent	Terracotta	1	Next Working Day	RTV-NPTE	130
Non-Profile Roof Tile Vent	Brown	1	Next Working Day	RTV-NPBR	130
Non-Profile Roof Tile Vent	Grey	1	Next Working Day	RTV-NPGR	130
Non-Profile Roof Tile Vent	Red	1	Next Working Day	RTV-NPRD	130
Non-Profile Roof Tile Vent	Black	1	Next Working Day	RTV-NPBL	130
Thin Leading Edge Roof Tile Vent	Terracotta	1	Next Working Day	RTV-TETE	131
Thin Leading Edge Roof Tile Vent	Brown	1	Next Working Day	RTV-TEBR	131
Thin Leading Edge Roof Tile Vent	Grey	1	Next Working Day	RTV-TEGR	131
Thin Leading Edge Roof Tile Vent	Red	1	Next Working Day	RTV-TERD	131
Thin Leading Edge Roof Tile Vent	Black	1	Next Working Day	RTV-TEBL	131
Interlocking Plain Roof Tile Vent	Terracotta	1	Next Working Day	RTV-IPTE	132
Interlocking Plain Roof Tile Vent	Brown	1	Next Working Day	RTV-IPBR	132
Interlocking Plain Roof Tile Vent	Grey	1	Next Working Day	RTV-IPGR	132
Interlocking Plain Roof Tile Vent	Red	1	Next Working Day	RTV-IPRD	132
Plain Roof Tile Vent	Terracotta	1	Next Working Day	RTV-PTE	133
Plain Roof Tile Vent	Brown	1	Next Working Day	RTV-PTBR	133
Plain Roof Tile Vent	Grey	1	Next Working Day	RTV-PGR	133
Plain Roof Tile Vent	Red	1	Next Working Day	RTV-PRD	133
Low Profile Plain Tile Vent	Terracotta	1	Next Working Day	RTV-LPTE	134
Low Profile Plain Tile Vent	Brown	1	Next Working Day	RTV-LPPBR	134
Low Profile Plain Tile Vent	Grey	1	Next Working Day	RTV-LPPGR	134
Low Profile Plain Tile Vent	Red	1	Next Working Day	RTV-LPPRD	134
Slip Plain Tile Vent	Terracotta	1	Next Working Day	RTV-SLIPTTE	135
Slip Plain Tile Vent	Brown	1	Next Working Day	RTV-SLIPBR	135
Slip Plain Tile Vent	Grey	1	Next Working Day	RTV-SLIPGR	135
Slip Plain Tile Vent	Red	1	Next Working Day	RTV-SLIPRD	135
Single Pantile Roof Tile Vent	Terracotta	1	Next Working Day	RTV-SPTE	136
Single Pantile Roof Tile Vent	Brown	1	Next Working Day	RTV-SPBR	136
Single Pantile Roof Tile Vent	Grey	1	Next Working Day	RTV-SPGR	136
Single Pantile Roof Tile Vent	Red	1	Next Working Day	RTV-SPRD	136
Mini Castellated Roof Tile Vent	Terracotta	1	Next Working Day	RTV-MCTE	137
Mini Castellated Roof Tile Vent	Brown	1	Next Working Day	RTV-MCBBR	137
Mini Castellated Roof Tile Vent	Grey	1	Next Working Day	RTV-MCGR	137
Mini Castellated Roof Tile Vent	Red	1	Next Working Day	RTV-MCRD	137
Universal Roof Tile Vent	Terracotta	1	Next Working Day	RTV-UNITE	138
Universal Roof Tile Vent	Brown	1	Next Working Day	RTV-UNIBR	138
Universal Roof Tile Vent	Grey	1	Next Working Day	RTV-UNIGR	138
Universal Roof Tile Vent	Red	1	Next Working Day	RTV-UNIRD	138
Universal Roof Tile Vent	Black	1	Next Working Day	RTV-UNIBL	138
Universal 22,000 Roof Tile Vent	Terracotta	1	Next Working Day	RTV-UNI2TE	139
Universal 22,000 Roof Tile Vent	Brown	1	Next Working Day	RTV-UNI2BR	139
Universal 22,000 Roof Tile Vent	Grey	1	Next Working Day	RTV-UNI2GR	139
Universal 22,000 Roof Tile Vent	Red	1	Next Working Day	RTV-UNI2RD	139
Universal 22,000 Roof Tile Vent	Black	1	Next Working Day	RTV-UNI2BL	139
Inline Slate Vent	Black	1	Next Working Day	RTV-ISBL	140
Small Inline Slate Vent	Black	1	Next Working Day	RTV-SISBL	141
Hooded Slate Vent	Black	1	Next Working Day	RTV-HSBL	142
Universal Hooded Slate Tile Vent	Black	5	Next Working Day	4001	143
Roof Slate Vent Pipe Adapter Kit	Black	1	Next Working Day	4101	143
Roof Slate Vent Pipe Adapter Only	Black	1	Next Working Day	4102	143
Roof Slate Vent Flexible PVC Pipe Only	White	1	Next Working Day	4103	143
Flexi-Pipe + Clamp	Black	1	Next Working Day	RTV-KIT1	144
Flexi-Pipe + RTV-ADS + Clamp	Black	1	Next Working Day	RTV-KIT2	144
Flexi-Pipe + RTV-ADP + Clamp	Black	1	Next Working Day	RTV-KIT3	144
Flexi-Pipe + RTV-ADIS + Clamp	Black	1	Next Working Day	RTV-KIT4	144
Multi Stepped Duct Adapter	Black	10	Next Working Day	RTV-ADMULTI	145
Hooded Slate Vent Adapter	Black	10	Next Working Day	RTV-ADHS	146
Standard Tile Vent Adapter	Black	12	Next Working Day	RTV-ADS	147
Plain Tile Vent Adapter	Black	12	Next Working Day	RTV-ADP	148
Inline Slate Vent Adapter	Black	10	Next Working Day	RTV-ADIS	149

CONSTRUCTION ACCESSORIES

CAVITY TRAYS

CAVITY CLOSERS

ACCESS PRODUCTS

ADAPT-AIR

RAD-SEAL

ROOFLINE

THROUGH-WALL VENTILATION

TOP HATS, GAS BARRIERS & DPC

METER BOXES

Through-Wall Ventilation (continued)

Description	Colour	Quantity	Lead Time	Product Code	Page No.
9 x 6" Through Wall Cavity Sleeve Extension +90mm Black	Black	1	Next Working Day	1236	151
9 x 3" Through Wall Cavity Sleeve Extension +90mm Black	Black	1	Next Working Day	1237	151
9 x 3" Through Wall Cavity Sleeve Baffle Black	Black	1	Next Working Day	1238	151
9 x 3" Through Wall Cavity Sleeve 1 Airbrick Black	Black	20	Next Working Day	1202/1	151
9 x 6" Through Wall Cavity Sleeve 2 Airbrick Black	Black	1	Next Working Day	1202/2	151
9 x 3" Face Fit External Cowl 255 x 95mm Brown	Brown	1	Next Working Day	ABC93BR	152
9 x 3" Face Fit External Cowl 255 x 95mm Terracotta	Terracotta	1	Next Working Day	ABC93TE	152
9 x 6" Face Fit External Cowl 255 x 160mm Brown	Brown	1	Next Working Day	ABC96BR	152
9 x 6" Face Fit External Cowl 255x160mm Terracotta	Terracotta	1	Next Working Day	ABC96TE	152
9 x 9" Face Fit External Cowl 255 x 230mm Brown	Brown	1	Next Working Day	ABC99BR	152
9 x 9" Face Fit External Cowl 255 x 230mm Terracotta	Terracotta	1	Next Working Day	ABC99TE	152
9x3 Plastic Internal Louvre Grille Vent White	White	1	Next Working Day	1207W	152
9x3 Plastic Internal Louvre Grille Vent Fly Screen White	White	1	Next Working Day	1207WF	152
9x3 Plastic Internal Hit and Miss Grille Vent White	White	1	Next Working Day	1208W	152
9x6 Plastic Internal Hit and Miss Grille Vent White	White	1	Next Working Day	1209W	152
9x9 Plastic Internal Hit and Miss Grille Vent White	White	1	Next Working Day	1210W	152
9x6 Plastic Internal Louvre Grille Vent White	White	1	Next Working Day	1211W	152
9x6 Plastic Internal Louvre Grille Vent Fly Screen White	White	1	Next Working Day	1211WF	152
9x9 Plastic Internal Louvre Grille Vent White	White	1	Next Working Day	1212W	152
9x9 Plastic Internal Louvre Grille Vent Fly Screen White	White	1	Next Working Day	1212WF	152
6x3 Plastic Internal Louvre Mini Vent White	White	1	Next Working Day	1218W	152
6x3 Plastic Internal Louvre Mini Vent Flyscreen White	White	1	Next Working Day	1218WF	152
6x3 Plastic Internal Hit and Miss Louvre Mini Vent White	White	1	Next Working Day	1219W	152
9x3 Metal Internal Hit and Miss Louvre Vent Aluminium	Aluminium	1	Next Working Day	1220A	152
9x3 Metal Internal Hit and Miss Louvre Vent Brass Anodised	Brass Anodised	1	Next Working Day	1220BA	152
9x3 Metal Internal Hit and Miss Louvre Vent Polished Brass	Polished Brass	1	Next Working Day	1220PB	152
9x6 Metal Internal Hit and Miss Louvre Vent Aluminium	Aluminium	1	Next Working Day	1221A	152
9x6 Metal Internal Hit and Miss Louvre Vent Brass Anodised	Brass Anodised	1	Next Working Day	1221BA	152
9x6 Metal Internal Hit and Miss Louvre Vent Polished Brass	Polished Brass	1	Next Working Day	1221PB	152
9x9 Metal Internal Hit and Miss Louvre Vent Aluminium	Aluminium	1	Next Working Day	1222A	152
9x9 Metal Internal Hit and Miss Louvre Vent Brass Anodised	Brass Anodised	1	Next Working Day	1222BA	152
9x9 Metal Internal Hit and Miss Louvre Vent Polished Brass	Polished Brass	1	Next Working Day	1222PB	152
9x3 Metal Internal Louvre Grille Vent Aluminium	Aluminium	1	Next Working Day	1223A	152
9x3 Metal Internal Louvre Grille Vent Brass Anodised	Brass Anodised	1	Next Working Day	1223BA	152
9x3 Metal Internal Louvre Grille Vent Polished Brass	Polished Brass	1	Next Working Day	1223PB	152
9x6 Metal Internal Louvre Grille Vent Aluminium	Aluminium	1	2-3 Working Days	1224A	152
9x6 Metal Internal Louvre Grille Vent Brass Anodised	Brass Anodised	1	2-3 Working Days	1224BA	152
9x6 Metal Internal Louvre Grille Vent Polished Brass	Polished Brass	1	Next Working Day	1224PB	152
9x9 Metal Internal Louvre Grille Vent Aluminium	Aluminium	1	2-3 Working Days	1225A	152
9x9 Metal Internal Louvre Grille Vent Brass Anodised	Brass Anodised	1	2-3 Working Days	1225BA	152
9x9 Metal Internal Louvre Grille Vent Polished Brass	Polished Brass	1	Next Working Day	1225PB	152
25.5 x 2 Return Air Grille Aluminium	Aluminium	1	Next Working Day	1226A	152
25.5 x 2 Return Air Grille Brass Anodised	Brass Anodised	1	Next Working Day	1226BA	152
5" Aero Core Through-Wall Vent Set Baffle 127x350	Aluminium	1	Next Working Day	ACV7BR	154
5" Aero Core Through-Wall Vent Set Baffle 127x350	Anodised Brass	1	Next Working Day	ACV7TE	154
5" Aero Core Through-Wall Vent Set Cowl & Baffle 127x350	Polished Brass	1	Next Working Day	ACV7CBBR	154
5" Aero Core Through-Wall Vent Set Cowl & Baffle 127x350	Aluminium	1	Next Working Day	ACV7CTE	154
5" Aero Core Through-Wall Vent High Rise & Baffle 127x350	Anodised Brass	1	Next Working Day	ACV7HRTE	154

Top Hats, Gas Barrier & DPC

Description	Colour	Quantity	Lead Time	Product Code	Page No.
Rigid Gas Barrier Top Hat Collar 55mm Diameter	Black	1	3- 5 Working Days	TH055	157
Rigid Gas Barrier Top Hat Collar 82mm Diameter	Black	1	3- 5 Working Days	TH082	157
Rigid Gas Barrier Top Hat Collar 110mm Diameter	Black	1	Next Working Day	TH110	157
Rigid Gas Barrier Top Hat Collar 135mm Diameter	Black	1	3- 5 Working Days	TH135	157
Rigid Gas Barrier Top Hat Collar 160mm Diameter	Black	1	3- 5 Working Days	TH160	157
Flexible Top Hat Pipe Collar 110mm Diameter	Black	1	Next Working Day	77110	157
Flexible Top Hat Pipe Collar 135mm Diameter	Black	1	Next Working Day	77135	157
Jubilee Clip for TH055 55mm Top Hat Collar 64-114mm	Black	1	Next Working Day	JCLIP5	157
Jubilee Clip for TH110 110mm Top Hat Collar 76-127mm	Black	1	Next Working Day	JCLIP6	157
Jubilee Clip for TH135 & TH160 Top Hat 114-165mm	Black	1	Next Working Day	JCLIP7	157
Gastite Sealing Tape 15m x 100mm	-	1	Next Working Day	GTAPE01	157
Plastic girth tape 75m x 50mm	-	1	Next Working Day	GTAPE02	157
1201 Top Hat	Black	1	Next Working Day	77120	158
Radon Sump	Black	1	Next Working Day	RSUMP01	159
Threshold Internal Protection Tray 930mm	Black	1	7-10 Working Days	TPT01	160

Meter Boxes

Description	Colour	Quantity	Lead Time	Product Code	Page No.
Electric Meter Box Recessed	White	1	Next Working Day	30011	164
Electric Meter Box Surface Mounted	White	1	Next Working Day	30012	165
Gas Meter Box Recessed	White	1	Next Working Day	30013	166
Gas Meter Box Surface Mounted	White	1	Next Working Day	30015	167
Universal Smart Gas Meter Box	White	1	Next Working Day	30017	168
Hockey stick - Internal Cavity	Black	1	Next Working Day	31001	169
Hockey stick - Surface Mounted	White	1	Next Working Day	31002	169
Electric 3 Phase Meter Box Surface Mounted	White	2	Next Working Day	30003	170
Electric 3 Phase Meter Box Recessed	White	4	Next Working Day	30002	171

Replacement parts

For spares and replacements

To help prolong the life of your Timloc product and keep it in top working order, Timloc offer a range of spare and replacement parts. If you require any assistance please contact us via email at sales@timloc.co.uk or call 01405 765 567.

Description	Quantity	Lead Time	Product Code
Barrel for Plastic Door 1169/KL	1	Next Working Day	25119
Key to Suit Plastic Access Panel KL and 1169/KL	1	Next Working Day	25127
Key for 1HR Fire Rated Steel Loft Access Doors/Access Panels 1161KL/APCKL	1	Next Working Day	1160/1KO
Plastic Key Hole Plug	1	Next Working Day	KEYPLUG
Plastic T-Key For Metal Loft And AP Budget Lock	1	Next Working Day	TKEY
Dry Fix Additional Ridge Batten Brackets	10	Next Working Day	44616
Replacement Door - Electric Recessed Meter Box	1	Next Working Day	30008
Replacement Door - Electric Surface Mounted Meter Box	1	Next Working Day	30008
Replacement Door - Gas Recessed Meter Box	1	Next Working Day	30014
Replacement Door - Gas Surface Mounted Meter Box	1	Next Working Day	30016
Replacement Door - Gas Universal Smart Meter Box	1	Next Working Day	30018
Gas Meter Box Repair Kit	1	Next Working Day	30022
Electric Meter Box Repair Kit	1	Next Working Day	30027

Commodity Codes

Country of origin and commodity codes for the Timloc product range

Construction Accessories

Product Code	Barcode	Commodity Code	Country of Origin
IW50BB	5036889026065	39259010	Great Britain
IW50BL	5036889026058	39259010	Great Britain
IW50BR	5036889026041	39259010	Great Britain
IW50BU	5036889026034	39259010	Great Britain
IW50CL	5036889026027	39259010	Great Britain
IW50GR	5036889026010	39259010	Great Britain
IW50TE	5036889026003	39259010	Great Britain
IW50WH	5036889025990	39259010	Great Britain
IW200BB	5036889026249	39259010	Great Britain
IW200BL	5036889026300	39259010	Great Britain
IW200BR	5036889026317	39259010	Great Britain
IW200BU	5036889026324	39259010	Great Britain
IW200CL	5036889026331	39259010	Great Britain
IW200GR	5036889026348	39259010	Great Britain
IW200TE	5036889026355	39259010	Great Britain
IW200WH	5036889026362	39259010	Great Britain
IW500EX	5036889026539	39259010	Great Britain
ZIN50	5036889028540	39259010	Great Britain
1143BB	5036889026232	39259010	Great Britain
1143BL	5036889003714	39259010	Great Britain
1143BR	5036889003707	39259010	Great Britain
1143BU	5036889003738	39259010	Great Britain
1143CL	5036889004902	39259010	Great Britain
1143GR	5036889003790	39259010	Great Britain
1143TE	5036889003745	39259010	Great Britain
1143WH	5036889003721	39259010	Great Britain
1144	5036889009891	39259010	Great Britain
DV1	5036889017902	39259010	Great Britain
DV2	5036889017919	39259010	Great Britain
DV3	5036889017926	39259010	Great Britain
IRD65BL	5036889018237	39259010	Great Britain
IRD80R	5036889007200	39259010	Great Britain
1201ABBB	5036889026072	39259010	Great Britain
1201ABBL	5036889006517	39259010	Great Britain
1201ABBR	5036889006500	39259010	Great Britain
1201ABBU	5036889006524	39259010	Great Britain
1201ABGR	5036889006531	39259010	Great Britain
1201ABTE	5036889006548	39259010	Great Britain
1201ABWH	5036889007705	39259010	Great Britain
1201	5036889006609	39259010	Great Britain
1201XL	5036889011634	39259010	Great Britain
1201XL+	5036889031540	39259010	Great Britain
1203	5036889006647	39259010	Great Britain
1204	5036889006623	39259010	Great Britain
1205	5036889006630	39259010	Great Britain
1206	5036889006654	39259010	Great Britain

Cavity Trays

Product Code	Barcode	Commodity Code	Country of Origin
10001	5036889010545	39259010	Great Britain
10002	5036889010552	39259010	Great Britain
10011	5036889002878	39259010	Great Britain
10012	5036889002885	39259010	Great Britain
10031	5036889002892	39259010	Great Britain
10041	5036889002908	39259010	Great Britain
10061	5036889002915	39259010	Great Britain
10062	5036889011542	39259010	Great Britain
10001P	5036889023101	39259010	Great Britain
10002P	5036889023118	39259010	Great Britain
10011P	5036889023019	39259010	Great Britain
10012P	5036889023026	39259010	Great Britain
10031P	5036889023033	39259010	Great Britain
10041P	5036889023040	39259010	Great Britain

Product Code	Barcode	Commodity Code	Country of Origin
10061P	5036889023057	39259010	Great Britain
10062P	5036889011610	39259010	Great Britain
7101-7102	Various	39259010	Great Britain
7103-7104	Various	39259010	Great Britain
7105-7106	Various	39259010	Great Britain
7107-7110	Various	39259010	Great Britain
7111-7120	Various	39259010	Great Britain
7121-7130	Various	39259010	Great Britain
7131	5036889000560	39259010	Great Britain
7132-7134	Various	39259010	Great Britain
7135	5036889000584	39259010	Great Britain
7136-7139	Various	39259010	Great Britain
7141	5036889000614	39259010	Great Britain
7142-7150	Various	39259010	Great Britain
7161	5036889000713	39259010	Great Britain
7162-7165	Various	39259010	Great Britain
7101P-7102P	Various	39259010	Great Britain
7103P-7110P	Various	39259010	Great Britain
7111P-7120P	Various	39259010	Great Britain
7121P-7130P	Various	39259010	Great Britain
7131P	5036889014475	39259010	Great Britain
7132P-7139P	Various	39259010	Great Britain
7141P-7150P	Various	39259010	Great Britain
7161P	5036889014505	39259010	Great Britain
7162P-7165P	Various	39259010	Great Britain
7201-7202	Various	39259010	Great Britain
7203-7210	Various	39259010	Great Britain
7211-7220	Various	39259010	Great Britain
7231	5036889000966	39259010	Great Britain
7232-7239	Various	39259010	Great Britain
7241-8250	Various	39259010	Great Britain
7261	5036889001116	39259010	Great Britain
7262-7265	Various	39259010	Great Britain
7201P-7210P	Various	39259010	Great Britain
7211P-7220P	Various	39259010	Great Britain
7231P-7239P	Various	39259010	Great Britain
7241P-8250P	Various	39259010	Great Britain
7261P-7265P	Various	39259010	Great Britain
IL2	5036889010323	39259010	Great Britain
IL4	5036889002342	39259010	Great Britain
EXT90	5036889011337	39259010	Great Britain
INT90	5036889011344	39259010	Great Britain
EXT135	5036889011351	39259010	Great Britain
INT135	5036889011368	39259010	Great Britain
SERH	5036889010583	39259010	Great Britain
SELH	5036889010590	39259010	Great Britain
IL2/E	5036889001727	39259010	Great Britain
EXT90/E	5036889010613	39259010	Great Britain
INT90/E	5036889010620	39259010	Great Britain
IL2P	5036889018121	39259010	Great Britain
IL4P	5036889018169	39259010	Great Britain
EXT90P	5036889017995	39259010	Great Britain
INT90P	5036889018220	39259010	Great Britain
2075/460/50	5036889003011	39259010	Great Britain
2075/460/75	5036889003028	39259010	Great Britain
2075/460/100	5036889003004	39259010	Great Britain
2075/460/150	5036889013935	39259010	Great Britain
2075/880/50	5036889003042	39259010	Great Britain
2075/880/75	5036889003059	39259010	Great Britain
2075/880/100	5036889003035	39259010	Great Britain
2075/880/150	5036889014062	39259010	Great Britain
2010/50	5036889009938	39259010	Great Britain
2010/75	5036889009945	39259010	Great Britain
2010/100	5036889009952	39259010	Great Britain
2010/150	5036889021916	39259010	Great Britain
2011/50	5036889009969	39259010	Great Britain
2011/75	5036889009976	39259010	Great Britain

Product Code	Barcode	Commodity Code	Country of Origin
2011/100	5036889009983	39259010	Great Britain
2011/150	5036889021909	39259010	Great Britain
2012/50	5036889009990	39259010	Great Britain
2012/75	5036889023262	39259010	Great Britain
2012/100	5036889023231	39259010	Great Britain
2013/50	5036889023255	39259010	Great Britain
2013/75	5036889023224	39259010	Great Britain
2013/100	5036889023248	39259010	Great Britain
2003/50	-	39259010	Great Britain
2003/75	5036889022012	39259010	Great Britain
2003/100	5036889021978	39259010	Great Britain
2003/150	5036889022883	39259010	Great Britain
2004/50	-	39259010	Great Britain
2004/75	5036889022005	39259010	Great Britain
2004/100	5036889021985	39259010	Great Britain
2004/150	5036889022890	39259010	Great Britain
2005/50	5036889021596	39259010	Great Britain
2005/75	5036889013485	39259010	Great Britain
2005/100	5036889021589	39259010	Great Britain
2006E/50	5036889013539	39259010	Great Britain
2006E/75	5036889013546	39259010	Great Britain
2006E/100	5036889013553	39259010	Great Britain
2007E/50	5036889013560	39259010	Great Britain
2007E/75	5036889013577	39259010	Great Britain
2007E/100	5036889013584	39259010	Great Britain
2075/460P50	5036889014055	39259010	Great Britain
2075/460P75	5036889021787	39259010	Great Britain
2075/460P100	5036889014031	39259010	Great Britain
2075/460P150	5036889014048	39259010	Great Britain
2075/880P50	5036889014178	39259010	Great Britain
2075/880P75	5036889014185	39259010	Great Britain
2075/880P100	5036889014161	39259010	Great Britain
2010P/50	5036889013676	39259010	Great Britain
2010P/75	5036889013683	39259010	Great Britain
2010P/100	5036889013690	39259010	Great Britain
2011P/50	5036889013782	39259010	Great Britain
2011P/75	5036889013779	39259010	Great Britain
2011P/100	5036889013805	39259010	Great Britain
2012P/50	5036889013843	39259010	Great Britain
2012P/75	5036889013850	39259010	Great Britain
2012P/100	5036889013867	39259010	Great Britain
2013P/50	5036889013904	39259010	Great Britain
2013P/75	5036889013911	39259010	Great Britain
2013P/100	5036889013928	39259010	Great Britain
LS01	5036889003509	39259010	Great Britain

Cavity Closers, Stops & Barriers

Product Code	Barcode	Commodity Code	Country of Origin
CC2.4PPS/MULTI100	5036889026218	39259010	Great Britain
CC2.4PPS/MULTI150	5036889026225	39259010	Great Britain
PP2.4/50	5036889026911	39259010	Great Britain
PP2.4/75	5036889026928	39259010	Great Britain
PP2.4/90	5036889026935	39259010	Great Britain
PP2.4/100	5036889026850	39259010	Great Britain
PP2.4/100MULTI	5036889026867	39259010	Great Britain
PP2.4/120	5036889026874	39259010	Great Britain
PP2.4/125	5036889026881	39259010	Great Britain
PP2.4/130	5036889026898	39259010	Great Britain
PP2.4/150	5036889026904	39259010	Great Britain
PP2.4/CR100MULTI	5036889026959	39259010	Great Britain
FX2.4/50	5036889027253	39259010	Great Britain
FX2.4/75	5036889027260	39259010	Great Britain
FX2.4/90	5036889027277	39259010	Great Britain
FX2.4/100	5036889027192	39259010	Great Britain

Product Code	Barcode	Commodity Code	Country of Origin
CC2.4PPS/MULTI100	5036889026218	39259010	Great Britain
CC2.4PPS/MULTI150	5036889026225	39259010	Great Britain
PP2.4/50	5036889026911	39259010	Great Britain
PP2.4/75	5036889026928	39259010	Great Britain
PP2.4/90	5036889026935	39259010	Great Britain
PP2.4/100	5036889026850	39259010	Great Britain
PP2.4/100MULTI	5036889026867	39259010	Great Britain
PP2.4/120	5036889026874	39259010	Great Britain
PP2.4/125	5036889026881	39259010	Great Britain
PP2.4/130	5036889026898	39259010	Great Britain
PP2.4/150	5036889026904	39259010	Great Britain
PP2.4/CR100MULTI	5036889026959	39259010	Great Britain
FX2.4/50	5036889027253	39259010	Great Britain
FX2.4/75	5036889027260	39259010	Great Britain
FX2.4/90	5036889027277	39259010	Great Britain
FX2.4/100	5036889027192	39259010	Great Britain
FX2.4/100MULTI	5036889027208	39259010	Great Britain
FX2.4/120	5036889027215	39259010	Great Britain
FX2.4/125	5036889027222	39259010	Great Britain
FX2.4/130	5036889027239	39259010	Great Britain
FX2.4/150	5036889027246	39259010	Great Britain
FX2.4/CR50	5036889027321	39259010	Great Britain
FX2.4/CR100	5036889027284	39259010	Great Britain
FX2.4/CR100MULTI	5036889027291	39259010	Great Britain
FX2.4/CR125	5036889027307	39259010	Great Britain
FX2.4/CR150	5036889027314	39259010	Great Britain
CC2.4FR/50	5036889023668	39259010	Great Britain
CC2.4FR/65	5036889025853	39259010	Great Britain
CC2.4FR/75	5036889002717	39259010	Great Britain
CC2.4FR/90	5036889025983	39259010	Great Britain
CC2.4FR/100	5036889002731	39259010	Great Britain
CC2.4FR/125	5036889025839	39259010	Great Britain
CC2.4FR/150	5036889025846	39259010	Great Britain
CC2.4FR/160	5036889025976	39259010	Great Britain
CC2.4FR/170	5036889026737	39259010	Great Britain
CC2.4FR/180	5036889027666	39259010	Great Britain
CC2.4FR/190	5036889025969	39259010	Great Britain
CC2.4FR/200	5036889026249	39259010	Great Britain
CC2.4FR/210	5036889025860	39259010	Great Britain
CC2.4FR/220	5036889026256	39259010	Great Britain
CC2.4FR/230	5036889027468	39259010	Great Britain
CC2.4FR/240	5036889026287	39259010	Great Britain
CC2.4FR/250	5036889026379	39259010	Great Britain
CC2.4FR/260	5036889026270	39259010	Great Britain
CC2.4FR/270	5036889028632	39259010	Great Britain
CC2.4FR/280	-	39259010	Great Britain
CC2.4FR/290	5036889028632	39259010	Great Britain
CC2.4FR/300	5036889026263	39259010	Great Britain
FR60/50	5036889026836	39259010	Great Britain
FR60/65	5036889028786	39259010	Great Britain
FR60/75	5036889027451	39259010	Great Britain
FR60/90	5036889027758	39259010	Great Britain
FR60/100	5036889026805	39259010	Great Britain
FR60/125	5036889026812	39259010	Great Britain
FR60/150	5036889026829	39259010	Great Britain
FR60/175	5036889027765	39259010	Great Britain
FR60/200	5036889027772	39259010	Great Britain
FR60/225	5036889027789	39259010	Great Britain
FR60/250	5036889027796	39259010	Great Britain
FR60/275	5036889027802	39259010	Great Britain

CONSTRUCTION
ACCESSORIES

CAVITY
TRAYS

CAVITY
CLOSERS

ACCESS
PRODUCTS

ADAPT-AIR

RAD-SEAL

ROOFLINE

THROUGH-WALL
VENTILATION

TOP HATS, GAS
BARRIERS & DPC

METER
BOXES

Product Code	Barcode	Commodity Code	Country of Origin
FR60/300	5036889027819	39259010	Great Britain
FR60/CR50	5036889027635	39259010	Great Britain
FR60/CR65	-	39259010	Great Britain
FR60/CR75	-	39259010	Great Britain
FR60/CR90	-	39259010	Great Britain
FR60/CR100	-	39259010	Great Britain
FR60/CR125	-	39259010	Great Britain
FR60/CR150	-	39259010	Great Britain
CCFIX	5036889002847	39259010	Great Britain
FRSTOP50	5036889028601	6806900000	Great Britain
FRSTOP75	5036889028618	6806900000	Great Britain
FRSTOP85	5036889028625	6806900000	Great Britain
FRSTOP90	5036889028700	6806900000	Great Britain
FRSTOP100	5036889028564	6806900000	Great Britain
FRSTOP115	5036889028571	6806900000	Great Britain
FRSTOP125	5036889028588	6806900000	Great Britain
FRSTOP150	5036889028595	6806900000	Great Britain

Access Products

Product Code	Barcode	Commodity Code	Country of Origin
1168	5036889006081	39259010	Great Britain
1168/25	5036889010491	39259010	Great Britain
1168/35	5036889004834	39259010	Great Britain
1169	5036889006098	39259010	Great Britain
1169KL	5036889006104	39259010	Great Britain
1169/25	5036889010507	39259010	Great Britain
1169/25KL	5036889010408	39259010	Great Britain
1169/35	5036889004841	39259010	Great Britain
1169/35KL	5036889004858	39259010	Great Britain
25119	5036889024023	73083000	Great Britain
25127	5036889024153	73083000	Great Britain
Z8001	5036889028007	73083000	China
Z8002	5036889028014	73083000	China
Z8003	5036889028021	73083000	China
Z8004	5036889028038	73083000	China
Z8005	5036889028045	73083000	China
Z8006	5036889028052	73083000	China
Z8007	5036889028069	73083000	China
Z8008	5036889028076	73083000	China
Z9001	5036889028083	73083000	China
Z9002	5036889028090	73083000	China
Z9003	5036889028106	73083000	China
Z9004	5036889028113	73083000	China
Z9005	5036889028120	73083000	China
Z9006	5036889028137	73083000	China
Z9007	5036889028144	73083000	China
Z9008	5036889028151	73083000	China
ZKL8001	5036889028250	73083000	China
ZKL8002	5036889028267	73083000	China
ZKL8003	5036889028274	73083000	China
ZKL8004	5036889028281	73083000	China
ZKL8005	5036889028298	73083000	China
ZKL8006	5036889028304	73083000	China
ZKL8007	5036889028311	73083000	China
ZKL8008	5036889028328	73083000	China
ZKL9001	5036889028335	73083000	China
ZKL9002	5036889028342	73083000	China
ZKL9003	5036889028359	73083000	China
ZKL9004	5036889028366	73083000	China
ZKL9005	5036889028373	73083000	China

Product Code	Barcode	Commodity Code	Country of Origin
ZKL9006	5036889028380	73083000	China
ZKL9007	5036889028397	73083000	China
ZKL9008	5036889028403	73083000	China
Z1162	5036889028427	73083000	China
Z1170	5036889028410	73083000	China
AP110	5036889004964	39259010	Great Britain
AP150	5036889007101	39259010	Great Britain
AP150KL	5036889001680	39259010	Great Britain
AP200	5036889007323	39259010	Great Britain
AP300	5036889007330	39259010	Great Britain
AP300KL	5036889001703	39259010	Great Britain
AP450	5036889007347	39259010	Great Britain
AP450KL	5036889001710	39259010	Great Britain
AP110AT	5036889010002	39259010	Great Britain
AP150AT	5036889010019	39259010	Great Britain
AP200AT	5036889010026	39259010	Great Britain
AP300AT	5036889010033	39259010	Great Britain
AP450AT	5036889010040	39259010	Great Britain
Z2001	5036889027918	73083000	China
Z2002	5036889027925	73083000	China
Z2003	5036889027932	73083000	China
Z2004	5036889027949	73083000	China
Z2005	5036889027956	73083000	China
Z2006	5036889027963	73083000	China
Z2007	5036889027970	73083000	China
Z2008	5036889027987	73083000	China
Z2009	5036889027994	73083000	China
APC150x150CR	5036889027826	73083000	China
APC150x230CR	5036889027833	73083000	China
APC200x200CR	5036889027840	73083000	China
APC300x300CR	5036889027857	73083000	China
APC450x450CR	5036889027871	73083000	China
APC550x550CR	5036889027888	73083000	China
APC600x600CR	5036889027901	73083000	China
APC150x150CRKL	5036889028168	73083000	China
APC150x230CRKL	5036889028175	73083000	China
APC200x200CRKL	5036889028182	73083000	China
APC300x300CRKL	5036889028199	73083000	China
APC450x450CRKL	5036889028212	73083000	China
APC550x550CRKL	5036889028229	73083000	China
APC600x600CRKL	5036889028243	73083000	China

Adapt-Air

Product Code	Barcode	Commodity Code	Country of Origin
6510BL	5036889018824	39259010	Great Britain
6510BR	5036889018817	39259010	Great Britain
6510BU	5036889018855	39259010	Great Britain
6510GR	5036889018831	39259010	Great Britain
6510TE	5036889018800	39259010	Great Britain
6510WH	5036889018848	39259010	Great Britain
6520BL	5036889025877	39259010	Great Britain
6520BR	5036889025884	39259010	Great Britain
6520BU	5036889025891	39259010	Great Britain
6520GR	5036889025907	39259010	Great Britain
6520TE	5036889025914	39259010	Great Britain
6520WH	5036889025921	39259010	Great Britain
3511BU	5036889026515	39259010	Great Britain
3511TE	5036889026522	39259010	Great Britain
6500BL	5036889018756	39259010	Great Britain
6500BR	5036889018749	39259010	Great Britain

Product Code	Barcode	Commodity Code	Country of Origin
6500BU	5036889018787	39259010	Great Britain
6500GR	5036889018763	39259010	Great Britain
6500TE	5036889018732	39259010	Great Britain
6500WH	5036889018770	39259010	Great Britain
6512BL	5036889027512	39259010	Great Britain
6512BR	5036889027529	39259010	Great Britain
6512BU	5036889026430	39259010	Great Britain
6512GR	5036889027536	39259010	Great Britain
6512TE	5036889026447	39259010	Great Britain
6512WH	5036889027543	39259010	Great Britain
6525BL	5036889027499	39259010	Great Britain
6525BR	5036889027482	39259010	Great Britain
6525BU	5036889027482	39259010	Great Britain
6525GR	5036889026478	39259010	Great Britain
6525TE	5036889026485	39259010	Great Britain
6525WH	5036889027369	39259010	Great Britain
6515BL	5036889027550	39259010	Great Britain
6515BR	5036889027567	39259010	Great Britain
6515BU	5036889026454	39259010	Great Britain
6515GR	5036889027574	39259010	Great Britain
6515TE	5036889026461	39259010	Great Britain
6515WH	5036889027581	39259010	Great Britain
6550BL	5036889027598	39259010	Great Britain
6550BR	5036889027604	39259010	Great Britain
6550BU	5036889026492	39259010	Great Britain
6550GR	5036889027611	39259010	Great Britain
6550TE	5036889026508	39259010	Great Britain
6550WH	5036889027628	39259010	Great Britain

Rad-Seal

Product Code	Barcode	Commodity Code	Country of Origin
2222	5036889031250	39259010	Great Britain
2221	5036889027833	39259010	Great Britain
1115	5036889009907	39259010	Great Britain

Roofline

Product Code	Barcode	Commodity Code	Country of Origin
1139	5036889025495	39259010	Great Britain
1140	5036889005299	39259010	Great Britain
1141	5036889005275	39259010	Great Britain
1142	5036889005282	39259010	Great Britain
1137BL	5036889005343	39259010	Great Britain
1137BR	5036889005367	39259010	Great Britain
1137WH	5036889005350	39259010	Great Britain
1138BR	5036889005404	39259010	Great Britain
1138WH	5036889005411	39259010	Great Britain
3012	5036889005480	39259010	Great Britain
3011BL	5036889005503	39259010	Great Britain
3011BR	5036889005510	39259010	Great Britain
3011WH	5036889005527	39259010	Great Britain
3011/25BL	5036889005565	39259010	Great Britain
3011/25W	5036889005589	39259010	Great Britain
OF1BL	5036889018312	39259010	Great Britain
OF2BL	5036889005916	39259010	Great Britain
3014	5036889005640	39259010	Great Britain
3014C	5036889005664	39259010	Great Britain
1121	5036889005251	39259010	Great Britain
1171	5036889027475	39259010	Great Britain
1131	5036889020940	39259010	Great Britain
1151	5036889025822	39259010	Great Britain

Product Code	Barcode	Commodity Code	Country of Origin
EVP6	5036889005763	39259010	Great Britain
EVP6/25	5036889017933	39259010	Great Britain
EVP6/25600	5036889021091	39259010	Great Britain
EVP6/600	5036889021084	39259010	Great Britain
1128	5036889007682	39259010	Great Britain
3017	5036889005725	39259010	Great Britain
1136	5036889005749	39259010	Great Britain
53700	5036889030536	39259010	Great Britain
54700	5036889027338	39259010	Great Britain
54618	5036889027703	39259010	Great Britain
54626	5036889026782	39259010	Great Britain
51700	5036889030543	39259010	Great Britain
54703	5036889030512	39259010	Great Britain
54710	5036889027673	39259010	Great Britain
54713	5036889031519	39259010	Great Britain
54715	5036889031526	39259010	Great Britain
54716	5036889031533	39259010	Great Britain
44623	5036889022210	39259010	Great Britain
44629	5036889031915	39259010	Great Britain
99141	5036889027031	39259010	Great Britain
99142	5036889027048	39259010	Great Britain
99143	5036889027055	39259010	Great Britain
99144	5036889027062	39259010	Great Britain
99109	5036889022562	39259010	Great Britain
99110	5036889022579	39259010	Great Britain
99183	5036889031861	39259010	Great Britain
99108	5036889022555	39259010	Great Britain
99107	5036889026577	39259010	Great Britain
99113	5036889022593	39259010	Great Britain
99114	5036889022609	39259010	Great Britain
99184	5036889031878	39259010	Great Britain
99112	5036889022586	39259010	Great Britain
99136	5036889026584	39259010	Great Britain
99153	5036889027154	39259010	Great Britain
99155	5036889027178	39259010	Great Britain
99154	5036889027161	39259010	Great Britain
99156	5036889027185	39259010	Great Britain
99124	5036889022678	73083000	Great Britain
99125	5036889022685	39259010	Great Britain
99126	5036889022692	39259010	Great Britain
99127	5036889022708	39259010	Great Britain
99130	5036889022739	39259010	Great Britain
99120	5036889022647	39259010	Great Britain
99121	5036889022654	39259010	Great Britain
99122	5036889022661	39259010	Great Britain
99138	5036889026553	39259010	Great Britain
99116	5036889022616	39259010	Great Britain
99117	5036889022623	39259010	Great Britain
99118	5036889022630	39259010	Great Britain
99137	5036889026546	39259010	Great Britain
99173	5036889031762	39259010	Great Britain
99174	5036889031779	39259010	Great Britain
99175	5036889031786	39259010	Great Britain
99182	5036889031854	39259010	Great Britain
99176	5036889031793	39259010	Great Britain
99177	5036889031809	39259010	Great Britain
99178	5036889031816	39259010	Great Britain
99179	5036889031823	39259010	Great Britain
99181	5036889031847	39259010	Great Britain
99180	5036889031830	39259010	Great Britain

CONSTRUCTION ACCESSORIES

CAVITY TRAYS

CAVITY CLOSERS

ACCESS PRODUCTS

ADAPT-AIR

RAD-SEAL

ROOFLINE

THROUGH-WALL VENTILATION

TOP HATS, GAS BARRIERS & DPC

METER BOXES

Product Code	Barcode	Commodity Code	Country of Origin	Product Code	Barcode	Commodity Code	Country of Origin
99157	5036889031601	39259010	Great Britain	RTV-PGR	5036889030093	39259010	Great Britain
99158	5036889031618	39259010	Great Britain	RTV-PRD	5036889030109	39259010	Great Britain
99159	5036889031625	39259010	Great Britain	RTV-LPSTE	5036889031090	39259010	Great Britain
99160	5036889031632	39259010	Great Britain	RTV-LPPBR	5036889031106	39259010	Great Britain
99161	5036889031649	39259010	Great Britain	RTV-LPPGR	5036889031113	39259010	Great Britain
99162	5036889031656	39259010	Great Britain	RTV-LPPRD	5036889031120	39259010	Great Britain
99163	5036889031663	39259010	Great Britain	RTV-SLIPSTE	5036889031137	39259010	Great Britain
99164	5036889031670	39259010	Great Britain	RTV-SLIPBR	5036889031144	39259010	Great Britain
99165	5036889031687	39259010	Great Britain	RTV-SLIPGR	5036889031151	39259010	Great Britain
99166	5036889031694	39259010	Great Britain	RTV-SLIPRD	5036889031168	39259010	Great Britain
99167	5036889031700	39259010	Great Britain	RTV-SSTE	5036889030154	39259010	Great Britain
99168	5036889031717	39259010	Great Britain	RTV-SBPR	5036889030123	39259010	Great Britain
99169	5036889031724	39259010	Great Britain	RTV-SPGR	5036889030130	39259010	Great Britain
99170	5036889031731	39259010	Great Britain	RTV-SPRD	5036889030147	39259010	Great Britain
99171	5036889031748	39259010	Great Britain	RTV-MCTE	5036889029363	39259010	Great Britain
99172	5036889031755	39259010	Great Britain	RTV-MCGR	5036889029332	39259010	Great Britain
66101	5036889022234	39259010	Great Britain	RTV-MCPR	5036889029349	39259010	Great Britain
66105	5036889022272	39259010	Great Britain	RTV-MCRD	5036889029356	39259010	Great Britain
66117	5036889022395	39259010	Great Britain	RTV-ISBL	5036889029301	39259010	Great Britain
66120	5036889022425	39259010	Great Britain	RTV-SISBL	5036889030697	39259010	Great Britain
66124	5036889022463	39259010	Great Britain	RTV-HSBL	5036889030710	39259010	Great Britain
5560	5036889028762	39259010	Great Britain	4001	5036889006418	39259010	Great Britain
AS-PLAIN	5036889031571	39259010	Great Britain	4101	5036889006746	39259010	Great Britain
AS-INTPLAIN	5036889031564	39259010	Great Britain	4102	5036889008542	39259010	Great Britain
AS-SLATE	5036889031588	39259010	Great Britain	4103	5036889021879	39259010	Great Britain
AS-TLE	5036889031595	39259010	Great Britain	RTV-UNITE	5036889030253	39259010	Great Britain
AS-FLAT	5036889031557	39259010	Great Britain	RTV-UNIBR	5036889030222	39259010	Great Britain
RTV-CTE	5036889028977	39259010	Great Britain	RTV-UNIGR	5036889030239	39259010	Great Britain
RTV-CBR	5036889028946	39259010	Great Britain	RTV-UNIRD	5036889030246	39259010	Great Britain
RTV-CGR	5036889028953	39259010	Great Britain	RTV-UNIBL	5036889030215	39259010	Great Britain
RTV-CRD	5036889028960	39259010	Great Britain	RTV-UNI2TE	5036889030741	39259010	Great Britain
RTV-DPSTE	5036889029011	39259010	Great Britain	RTV-UNI2BR	5036889030765	39259010	Great Britain
RTV-DPBR	5036889028984	39259010	Great Britain	RTV-UNI2GR	5036889030802	39259010	Great Britain
RTV-DPGR	5036889028991	39259010	Great Britain	RTV-UNI2RD	5036889030789	39259010	Great Britain
RTV-DPRD	5036889029004	39259010	Great Britain	RTV-UNI2BL	5036889030826	39259010	Great Britain
RTV-DRSTE	5036889029059	39259010	Great Britain	RTV-KIT1	5036889029257	73083000	Great Britain
RTV-DRBR	5036889029028	39259010	Great Britain	RTV-KIT2	5036889029318	39259010	Great Britain
RTV-DRGR	5036889029035	39259010	Great Britain	RTV-KIT3	5036889029325	39259010	Great Britain
RTV-DRRD	5036889029042	39259010	Great Britain	RTV-KIT4	5036889030567	39259010	Great Britain
RTV-FESTE	5036889029103	39259010	Great Britain	RTV-ADMULTI	5036889028908	39259010	Great Britain
RTV-FEBR	5036889029073	39259010	Great Britain	RTV-ADHS	5036889030734	39259010	Great Britain
RTV-FEGR	5036889029080	39259010	Great Britain	RTV-ADS	5036889028922	39259010	Great Britain
RTV-FERD	5036889029097	39259010	Great Britain	RTV-ADP	5036889028915	39259010	Great Britain
RTV-FEBL	5036889029066	39259010	Great Britain	RTV-ADIS	5036889028892	39259010	Great Britain
RTV-NPSTE	5036889030079	39259010	Great Britain	MEM11550	5036889030895	56039390	China
RTV-NPBR	5036889030048	39259010	Great Britain	MEM11575	5036889030901	56039390	China
RTV-NPGR	5036889030093	39259010	Great Britain	MEM13550	5036889030918	56039390	China
RTV-NPRD	5036889030109	39259010	Great Britain	MEM13575	5036889030925	56039390	China
RTV-NPBL	5036889030031	39259010	Great Britain	MEM16550	5036889031397	56039390	China
RTV-TESTE	5036889030208	39259010	Great Britain	MEM16575	5036889031403	56039390	China
RTV-TEBR	5036889030178	39259010	Great Britain	LF150	5036889031434	39259010	China
RTV-TEGR	5036889030185	39259010	Great Britain	LF300	5036889031441	39259010	China
RTV-TERD	5036889030192	39259010	Great Britain	LF450	5036889031458	39259010	China
RTV-TEBL	5036889030161	39259010	Great Britain				
RTV-IPSTE	5036889029295	39259010	Great Britain				
RTV-IPBR	5036889029110	39259010	Great Britain				
RTV-IPGR	5036889029127	39259010	Great Britain				
RTV-IPRD	5036889029134	39259010	Great Britain				
RTV-PSTE	5036889030116	39259010	Great Britain				
RTV-PBR	5036889030086	39259010	Great Britain				

Through-Wall Ventilation

Product Code	Barcode	Commodity Code	Country of Origin
1236	5036889009877	39259010	Great Britain
1237	5036889009860	39259010	Great Britain
1238	5036889010781	39259010	Great Britain
1202/1	5036889006807	39259010	Great Britain

CONSTRUCTION ACCESSORIES

CAVITY TRAYS

CAVITY CLOSERS

ACCESS PRODUCTS

ADAPT-AIR

RAD-SEAL

ROOFLINE

THROUGH-WALL VENTILATION

TOP HATS, GAS BARRIERS & DPC

METER BOXES

Product Code	Barcode	Commodity Code	Country of Origin
1202/2	5036889006818	39259010	Great Britain
1207W	5036889006777	39259010	Great Britain
1207WF	5036889006128	39259010	Great Britain
1208W	5036889006869	39259010	Great Britain
1209W	5036889006876	39259010	Great Britain
1210W	5036889006883	39259010	Great Britain
1211W	5036889006845	39259010	Great Britain
1211WF	5036889006364	39259010	Great Britain
1212W	5036889006852	39259010	Great Britain
1212WF	5036889006555	39259010	Great Britain
1218W	5036889006005	39259010	Great Britain
1218WF	5036889007002	39259010	Great Britain
1219W	5036889007064	39259010	Great Britain
1220A	5036889003325	73083000	Great Britain
1220BA	5036889003332	73083000	Great Britain
1220PB	5036889003349	73083000	Great Britain
1221A	5036889003356	73083000	Great Britain
1221BA	5036889003363	73083000	Great Britain
1221PB	5036889003370	73083000	Great Britain
1222A	5036889003387	73083000	Great Britain
1222BA	5036889003394	73083000	Great Britain
1222PB	5036889003400	73083000	Great Britain
1223A	5036889003417	73083000	Great Britain
1223BA	5036889003424	73083000	Great Britain
1223PB	5036889003431	73083000	Great Britain
1224A	5036889003448	73083000	Great Britain
1224BA	5036889003455	73083000	Great Britain
1224PB	5036889003462	73083000	Great Britain
1225A	5036889003479	73083000	Great Britain
1225BA	5036889003486	73083000	Great Britain
1225PB	5036889003493	73083000	Great Britain
1226A	5036889003684	39259010	Great Britain
1226BA	5036889003691	39259010	Great Britain
ABC93BR	5036889017469	39259010	Great Britain
ABC93TE	5036889017483	39259010	Great Britain
ABC96BR	5036889017490	39259010	Great Britain
ABC96TE	5036889017513	39259010	Great Britain
ABC99BR	5036889017520	39259010	Great Britain
ABC99TE	5036889017544	39259010	Great Britain
ACV7BR	5036889017674	39259010	Great Britain
ACV7CBR	5036889009549	39259010	Great Britain
ACV7CTE	5036889009174	39259010	Great Britain
ACV7CWH	5036889009181	39259010	Great Britain
ACV7HRTE	5036889009204	39259010	Great Britain
ACV7TE	5036889009143	39259010	Great Britain

Top Hats, Gas Barriers & DPC Accessories

Product Code	Barcode	Commodity Code	Country of Origin
TH055	5036889007408	39259010	Great Britain
TH082	5036889007415	39259010	Great Britain
TH110	5036889007392	39259010	Great Britain
TH135	5036889018510	39259010	Great Britain
TH160	5036889007422	39259010	Great Britain
77110	5036889025938	39259010	Great Britain
JCLIP5	5036889018268	39259010	Great Britain
JCLIP6	5036889018275	39259010	Great Britain
JCLIP7	5036889018282	39259010	Great Britain
77120	5036889011627	39259010	Great Britain
RSUMP01	5036889007439	39259010	Great Britain
GTAPE01	5036889027307	39259010	Great Britain

Product Code	Barcode	Commodity Code	Country of Origin
GTAPE02	5036889027314	39259010	Great Britain
TPT01	5036889007446	39259010	Great Britain

Meter Boxes

Product Code	Barcode	Commodity Code	Country of Origin
30008	5036889026607	39259010	Great Britain
30011	5036889026591	39259010	Great Britain
30012	5036889026614	39259010	Great Britain
30013	5036889026652	39259010	Great Britain
30014	5036889026669	39259010	Great Britain
30015	5036889026676	39259010	Great Britain
30016	5036889026683	39259010	Great Britain
30017	5036889026690	39259010	Great Britain
30018	5036889026706	39259010	Great Britain
31001	5036889026638	39259010	Great Britain
31002	5036889026645	39259010	Great Britain

Hedgehog Highway

Product Code	Barcode	Commodity Code	Country of Origin
5551	5036889027642	39259010	Great Britain
5552	5036889027659	39259010	Great Britain
7771	5036889028823	39259010	Great Britain
7772	5036889028830	39259010	Great Britain
8881	5036889028847	39259010	Great Britain
8882	5036889028854	39259010	Great Britain
9991	5036889028861	39259010	Great Britain
9992	5036889028878	39259010	Great Britain

CONSTRUCTION
ACCESSORIES

CAVITY
TRAYS

CAVITY
CLOSERS

ACCESS
PRODUCTS

ADAPT-AIR

RAD-SEAL

ROOFLINE

THROUGH-WALL
VENTILATION

TOP HATS, GAS
BARRIERS & DPC

METER
BOXES

Alumasc Building Products Limited (trading as Timloc Building Products)
General Terms and Conditions for the Sales of Goods and Services

The Customer shall ensure that its employees and other staff (including contractors and staff of the Customer's suppliers, service providers and agents) are aware of Alumasc's Privacy Notices at <http://www.alumasc.co.uk/privacy-policy/> and shall ensure that the Privacy Notice is read and understood by such employees and staff before their personal data is provided to Alumasc.

1.1 All orders are accepted subject to the following terms and conditions which shall form part of and govern the Contract of Sale.

1.2 In these conditions the seller means Timloc Building Products trading as an agent for Alumasc Building Products Limited and the buyer means the party to whom this document is addressed.

1.3 These terms and conditions apply in preference to and supersede any terms and conditions referred to or offered by the seller whether in negotiation or at any stage in the dealings between the seller and buyer with reference to the goods to which this contract relates. Without prejudice to the generality of the foregoing, the seller will not be bound by any standard or printed terms furnished by the buyer in any of its documents, unless the buyer specifically states in writing separately from such terms that it intends such terms to apply and the seller acknowledges such notification in writing.

1.4 Neither the buyer nor the seller shall be bound by any variation, waiver of, or addition to these conditions except as agreed by both parties in writing and signed on their behalf.

2. Quotations

2.1. The placing of an order following the seller's quotation shall not be binding on the seller unless and until accepted by the seller in writing. An order accepted by the seller may only be cancelled or varied with the seller's consent; the giving of the seller's consent shall not in anyway prejudice the seller's right to recover from the buyer full compensation for any loss or expense arising from such cancellation or variation.

2.2. Additions or alterations to orders, however made, shall not be binding on the seller until they have been confirmed by the seller in writing.

3. Prices

3.1. The prices quoted are based on current conditions and are subject to adjustment on or after acceptance without notice. The goods will be invoiced at the price ruling on the date of despatch.

3.2. The prices quoted are exclusive of Value Added Tax, unless otherwise specifically stated in the contract. Any variation to prices resulting from taxes or levies will be for the buyer's account.

4. Delivery

4.1. Where goods are ordered by the buyer for delivery at his request:

- if a period is stated for delivery and such period is not extended by agreement in writing the buyer shall take delivery within that period.
- if no period is stated for delivery, the buyer shall take delivery of the goods as soon as they are ready.
- if the buyer does not take delivery of the goods within the period the buyer will reimburse the seller's storage and insurance costs. An invoice will be issued for the full amount of the goods plus storage costs on the last date on which delivery is due and shall be payable in accordance with the provisions of clause 11.1.

4.2. in any other case:

- any time stated in respect of delivery is given in good faith but it is by way of estimation only and is not binding on the seller.
- time for delivery, whether expressly stated or not, shall not be or be deemed to be of the essence of the contract of sale.

4.3. The seller will deliver the goods as near as possible to the delivery address as a safe hard road permits. The buyer shall provide at his own expense the labour for unloading and stacking. The buyer shall unload with utmost despatch. Damage caused to the goods due to inadequate site access or careless unloading shall be at the buyer's expense.

4.4. The seller shall not be liable for any loss or damage whether direct or indirect or consequential (including loss of profit, loss of business, the depletion of goodwill or other economic loss), or in whatsoever way arising which is or might be occasioned to the buyer or to any purchaser from his or a customer's of his arising out of, or in any way due to any delay or default in delivery of any goods under the contract however caused.

4.5. The seller shall be entitled to make partial delivery of the goods unless otherwise agreed in writing.

4.6. In the case of partial delivery of the goods the buyer will not be entitled to treat the delivery of faulty goods in any one partial delivery or the late delivery of any partial delivery as a repudiation of the whole contract.

4.7. By prior arrangement, the seller may accept the return of goods previously delivered to a buyer's branch. A credit note will be issued subject to conditions 4.7 (i) to (vi).

- The buyer must notify the seller of their intention to return the goods no later than three working days from the delivery date.
- Goods must be in their original saleable condition verified by, photographic evidence may be required.
- A re-stocking charge of 25% of the original order value will be payable by the buyer.
- The buyer is responsible for returning the goods, at their own expense, to the seller.
- Goods delivered direct to a site operated by the buyer's customer cannot be returned.
- Made to order products cannot be returned.

4.8. Orders of made to order products cannot be cancelled after the order acknowledgment has been sent by the seller.

5. Packing, Consignment and Carriage

5.1. Unless otherwise stated in the contract the goods will be consigned by the method of transport chosen by the seller to the delivery address specified by the buyer for the consignment of the goods ('delivery address' or, where the delivery address is not within the United Kingdom, F.O.B. in a United Kingdom port).

5.2. If packaging is marked 'returnable' it is not included in the price, but will be charged for unless returned within one month, carriage paid and in good condition to the seller's premises.

6. Transfer of Risk

6.1. The goods shall be at the risk of the buyer as soon as they are delivered to the delivery address or where the delivery address is not within the United Kingdom immediately the goods are placed on board a ship unless otherwise agreed in writing.

7. Acceptance of Goods

7.1. The buyer will be deemed to have accepted the goods unless he rejects them within three working days after their receipt at the delivery address.

7.2. The seller shall have no liability for goods delivered in a damaged or defective condition or lost in transit or for shortages in delivery unless:

- in the case of damage or defect or shortage of delivery, details are endorsed by the buyer on the carrier's delivery note or receipt and notice in writing giving full particulars of the damage or defect or shortage is received by the seller and the carrier within three working days after receipt of the goods at the delivery address.
- in the case of goods lost in transit, notice in writing, or by email to sales@timloc.co.uk, of the non-delivery is received by the seller and by the carrier within three working days after the date of the advice note or invoice (as the case may be) issued by the seller.

7.3. If shortage of delivery does take place the buyer undertakes not to reject the goods but to accept the goods delivered as part performance of the contract.

7.4. Subject to the buyer complying with Clauses 7.1 or 7.2 of the above (as the case may be) and subject to Clause 8 below, the seller shall replace or make good any goods rejected by the buyer or delivered in a damaged or defective condition or lost in transit (or in lieu thereof, at the option of the seller, shall allow credit to the buyer of the amount of the price of the goods lost or rejected or a proportionate amount thereof in the case of goods damaged) but the seller shall have no other liability whatsoever (other than liability for death or personal injury due to the seller's negligence) including consequential loss (including loss of profit, loss of business, the depletion of goodwill or other economic loss), in respect of goods rejected by the buyer or delivered in a damaged or defective condition or lost in transit. It shall be the duty of the buyer to insure against such consequential loss and to hold the seller harmless therefore.

7.5. All warranties, conditions and other terms implied by statute or common law (save for the conditions implied by Section 12 of the Sales of Goods Act 1979) are, to the fullest extent permitted by law, excluded from the contract.

7.6. The total amount of any liability under this contract shall be limited to the value of the contract.

8. Specifications

8.1. Unless otherwise specifically stated in the contract all specifications and particulars of weights and dimensions stated in the contract and in the seller's sales literature are approximate only and where dimensions or weights are quoted in imperial measurements the seller reserves the right to supply any convenient metric equivalent or vice versa.

8.2. Whilst every effort is made for these figures to be accurate, it must be understood that the specification of goods manufactured and supplied by the seller is subject to normal trade tolerances.

8.3. The seller reserves the right to change the specification of any goods quoted in its sales literature at any time without notice.

8.4. Whilst the seller takes every precaution in the preparation of its literature, these documents are for the buyer's general guidance only and the particulars contained therein shall not constitute representations by the seller and the seller shall not be bound thereby.

9. Design

9.1. It is the buyer's responsibility to ensure that all necessary approvals have been granted before manufacture commences. The seller will assist in supplying drawings and calculations when requested to do so. No design work or calculations will be issued prior to the placing of a firm order or contract. An additional charge will be made for any design work or drawings required over and above those normally supplied by the seller. It is the buyer's responsibility to satisfy himself that the drawings, calculations and specifications are correct and that the goods are suitable and fit for purpose, as no responsibility for omissions or errors will be accepted by the seller after the buyer has approved details submitted. The placing of an order by the buyer shall be deemed to be acceptance and approval by the buyer of the details submitted. The seller's responsibility in any event is solely confined to its own manufactured components and does not extend to other products or components or overall structural or architectural considerations. Where Timloc products have been offered as "equal or approved" such products may have different features from those shown in original specifications and the purchase by the buyer of such Timloc products under these circumstances shall be deemed to be acceptance of this fact, and remain at the buyer's risk and responsibility.

10. Intellectual Property Rights

10.1. The property and any copyright or other intellectual property rights in any documents or other materials, and any data or other information provided by the Seller relating to the Goods shall (unless otherwise agreed in writing between the Buyer and the Seller) at all times be and remain exclusively in the ownership of the Seller, subject only to a licence in favour of the Buyer to use such documents or materials for the purposes of receiving the Goods.

11. Payment

11.1. Except where otherwise specifically agreed, payment must be made to the seller's address stated on his invoice not later than the last day of the month following the date of invoice.

11.2. Where partial delivery is made the buyer shall be obliged to pay for each instalment separately, if the seller so requires by invoicing him.

11.3. Time for payment is of the essence.

11.4. If payment is not made on the due date the seller shall be entitled to:

- charge interest on the outstanding amount at the rate of 4% above Lloyds Bank Plc base rate accruing daily;
- require payment in advance of delivery of undelivered goods;
- refuse to make delivery of any undelivered goods whether ordered under the contract or not and without incurring any liability whatever to the buyer for non-delivery or any delay in delivery.
- to terminate the contract.
- to enforce the terms of Clauses 11.2 and 11.3

11.5. Unless otherwise agreed in writing by the seller the buyer shall not be entitled to exercise any right of set-off or counterclaim against monies owed to the seller for goods invoiced and delivered to him.

12. Ownership of Goods

12.1. Subject to the following clauses, the goods shall remain the seller's property until payment in full of the price, interest charges and all other monies due to the seller under this contract and all other contracts between the seller and the buyer, notwithstanding any processing of the same or incorporation of the same into a larger piece of equipment or structure.

12.2. The buyer shall be entitled to sell the goods in the ordinary course of business, provided that the proceeds of the sale shall be held in trust for the seller by the buyer until payment of all sums due to the seller by the buyer under this contract and all other contracts between the seller and buyer.

12.3. Should the buyer default in any payment when due the seller will be entitled to repossess all the goods held by the buyer which are still the seller's property (without prejudice to any other right or remedy arising out of such default in payment) and for this purpose the seller will be entitled to enter upon any land or buildings on or in which the goods may be situated and to remove the same. All costs incurred by the seller in repossessing the goods shall be borne by the buyer.

13. Patents

13.1. The buyer shall indemnify the seller against all damages penalties costs and expenses to which the seller may be liable as a result of work done in accordance with the buyer's specification which involves the infringement of any letters patent or registered design.

14. Determination of Contract

14.1. If the buyer shall make default in or commit a breach of the contract or of any other of his obligations to the seller, or the Buyer has a bankruptcy order made against him or makes an arrangement or composition with his creditors, or otherwise takes the benefit of any Act for the time being in force for the relief of insolvent debtors, or (being a body corporate) convenes a meeting of creditors (whether formal or informal), or enters into liquidation (whether voluntary or compulsory) except a solvent voluntary or compulsory) except a solvent voluntary liquidation for the purpose only of reconstruction or amalgamation, or has a receiver and/or manager, administrator or administrative receiver appointed of its undertaking or any part thereof, or a resolution is passed or a petition presented to any court for the winding up of the Buyer or for the granting of an administration order in respect of the Buyer, or any proceedings are commenced relating to the insolvency or possible insolvency of the Buyer; or the Buyer suffers or allows any execution, whether legal or equitable, to be levied on his/its property or obtained against him/it, or fails to observe/perform any of his/its obligations under the Contract or any other contract between the Seller and the Buyer, or is unable to pay its debts within the meaning of section 123 of the Insolvency Act 1986 or the Buyer ceases to trade, the seller shall have the right by written notice to the buyer to determine this and/or any other contract then subsisting between the buyer and the seller, and/or suspend further deliveries of goods under this and/or any other contract between the buyer and the seller. Such right shall be without prejudice to any other claim or right the seller may otherwise make to exercise.

15. Notices

15.1. Notices required to be given to the seller must be in writing and sent by first class post to the address stated on the front of this document. Notices required to be given to the buyer will be sent by first class post to the address specified by the buyer for the consignment of the goods unless a different address is specified for this purpose by the buyer. Notices shall be deemed to have been delivered on the next business day after the day of posting. In proving service by first class post it shall only be necessary to prove that the notice was contained in an envelope which was duly addressed and posted in accordance with this clause.

16. Other Conditions

16.1. No liability will be accepted by the seller for any failure of, or delay in, performance which is due wholly or partially to restriction by Government or other competent authority, strikes, lock-outs, failure by suppliers to supply raw materials or bought in goods or components or to any other cause whatsoever outside the seller's reasonable control.

16.2. Any waiver by the seller of its rights hereunder in respect of breach by the buyer shall not affect the rights of the seller in the event of a subsequent breach by the buyer.

17. Law

17.1. These conditions and the contract shall be subject to and construed in accordance with English Law and the buyer is deemed to submit to the non-exclusive jurisdiction of the English Courts.

GUIDES

Whether you need comprehensive product information, condensed data on a specific category, or an update on Timloc's ESG developments, we will have the guide to suit.



Scan the QR code for digital versions of the Timloc product guide, category guides and datasheets. For print copies, please email sales@timloc.co.uk



PRODUCT GUIDE | A4

A4 product guide consisting of datasheets, codes and pack quantities for the entire Timloc product range.

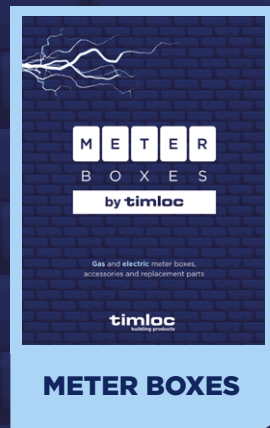
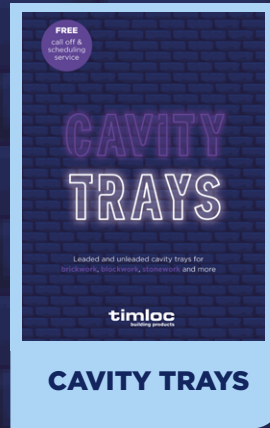
SUSTAINABILITY GUIDE | A4

Information on the steps Timloc has taken to be at the forefront of sustainability in our industry.



CATEGORY GUIDES | A5

Key information, codes and pack quantities for individual product categories when the full product guide is not required.



Timloc House, Ozone Park, Howden, East Yorkshire, DN14 7SD

T: 01405 765 567 **W:** www.timloc.co.uk

Sales: sales@timloc.co.uk

Technical: technical@timloc.co.uk

